



FIRE PROTECTION AND SMOKE EXTRACTION

Smoke control damper EKM90



Table of contents

EKM90 smoke control damper

Table of contents

1	Product overview	3
2	Product	4
3	Product description	6
3.1	Transportation protection	6
3.2	Area of use	7
3.3	Function	7
3.4	Accessories	8
3.4.1	Additional casing for $NH \geq 800$ mm	8
3.4.2	Casing extension for NH of ≤ 600 mm	8
3.4.3	Terminal strip	8
3.4.4	VK extension frame	9
3.4.5	Al connecting frame	9
3.4.6	A2 connecting frame	9
3.4.7	Protective grille	10
3.4.8	Handles	10
3.4.9	Connecting seal	10
3.4.10	Wall anchor	10
4	Installation overview	11
5	Installation	12
5.1	Installation positions	12
5.2	Installation openings: Dimensions and requirements	13
5.2.1	Rigid walls	13
5.2.2	Rigid ceilings	13
5.2.3	Metal stud walls clad on both sides	14
5.2.4	Lightweight shaft walls with metal stud frame and cladding on one side	15
5.2.5	Smoke extraction ducts with fire resistance period	15
5.3	Details of the installation work	16
5.3.1	Installing supports	16
5.3.2	Installing and gluing the strips	16
5.3.3	Installing wall anchors	17
5.3.4	Waterproofing and coating	17
5.3.5	Fire-resistant suspensions and attachments	17
5.4	Installation in rigid walls	18
5.4.1	Wet installation	18
5.4.2	Dry installation	19
5.5	Installation in metal stud walls	20
5.5.1	Wet installation	20
5.5.2	Dry installation	21
5.6	Installation in lightweight shaft wall	22
5.6.1	Dry installation	22
5.7	Installation in rigid ceilings	24
5.7.1	Wet installation	24
5.7.2	Dry installation	25
5.8	Connection to smoke extraction duct	26
6	Technical data	29
6.1	Dimensions	29
6.2	Free cross-sections	30
6.3	Weights	31
6.4	Pressure drop, flow velocity and sound power level	33
6.5	Electric actuators	35
7	Specification text	37
7.1	EKM90 smoke control damper	37
7.2	Accessories	38
8	Wildeboer makes it simple	40
8.1	Wildeboer Configurator	40
8.2	WiDim dimensioning software	40
8.3	Documents online	40

Overview

EKM90 smoke control damper

1 Product overview

The EKM90 smoke control damper with casing and blades made of abrasion-resistant, corrosion-resistant calcium silicate, suitable for high temperatures. With electric actuators for 24 V AC/DC or 230 V AC and stainless steel shafts, opening and closing is possible even when the fan is running and at inflow velocities of up to 20 m/s. Seals without any additional limit stops make for large free cross-sections and therefore low pressure drops and sound power levels.

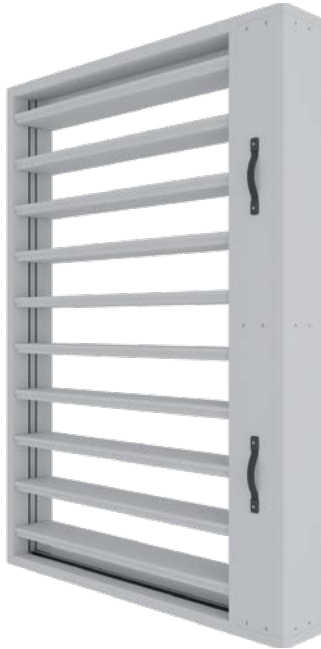

- Sizes: Nominal widths: 200 ... 1200 mm, 50 mm increments
Nominal heights: 200 ... 2000 mm, 200 mm increments
Lengths: 220 mm (all sizes)
- Declaration of Performance: DoP No. CPR/EKM90/002
- Reaction to fire certificate: MPA-BS 6000/718/22
- Environmental product declaration: EPD-WIL-20230374-ICA1-DE
- Leaktightness according to DIN EN 1751: Casing class C
- Blade coupling: Synchronous operation (SO)
- Max. flow rate: 155,520 m³/h
- Power supply to the actuators: 24 V AC/DC | 230 V AC
- Speed range: 0 ... 20 m/s
- Pressure range: Pressure level 2: -1000 ... 500 Pa operating pressure
- Maintenance-free: The actuator unit is fully enclosed, which means that no cleaning or regular lubrication and adjustment need to be done to maintain function
- Installation position with horizontal or vertical shaft position
- Actuator shafts made of stainless steel
- Casing and blades made of calcium silicate

Classification:

EI 90/120 (v_{edw} - h_{odw} - $i \Leftrightarrow o$) S1000 C_{mod} HOT400/30 MA multi

EI90/120 90/120 minutes fire resistance period

v_{ed} in and on horizontal smoke extraction ducts

h_{od} in and on vertical smoke extraction ducts

v_{ew} in rigid and shaft walls, in metal stud walls with double-sided cladding and lightweight shaft walls

h_{ow} in rigid ceilings

$i \Leftrightarrow o$ Verified exposure to fire on both sides

S1000 For smoke extraction systems with operating pressures between 1000 Pa negative pressure and 500 Pa positive pressure (pressure level 2). Smoke-tight at up to 1000 Pa differential pressure

C_{mod} For smoke extraction only systems and for combined systems including ventilation and air extraction as heating, ventilation and air conditioning (HVAC) systems. Intermediate damper blade positions for adjusting the volume flow rate are approved (modulation mode). The service life is verified with 20,000 weight-loaded cycles

HOT The smoke control dampers close and open for at least 30 minutes when exposed to a 400°C fire

MA Manual activation: Closed smoke control dampers can still be opened after 25 minutes of full exposure to fire (> 800 °C)

AA Automatic activation (included in MA classification)

multi The smoke control dampers may be used between fire compartments (multi) and in individual areas (single)

Product

EKM90 smoke control damper

2 Product

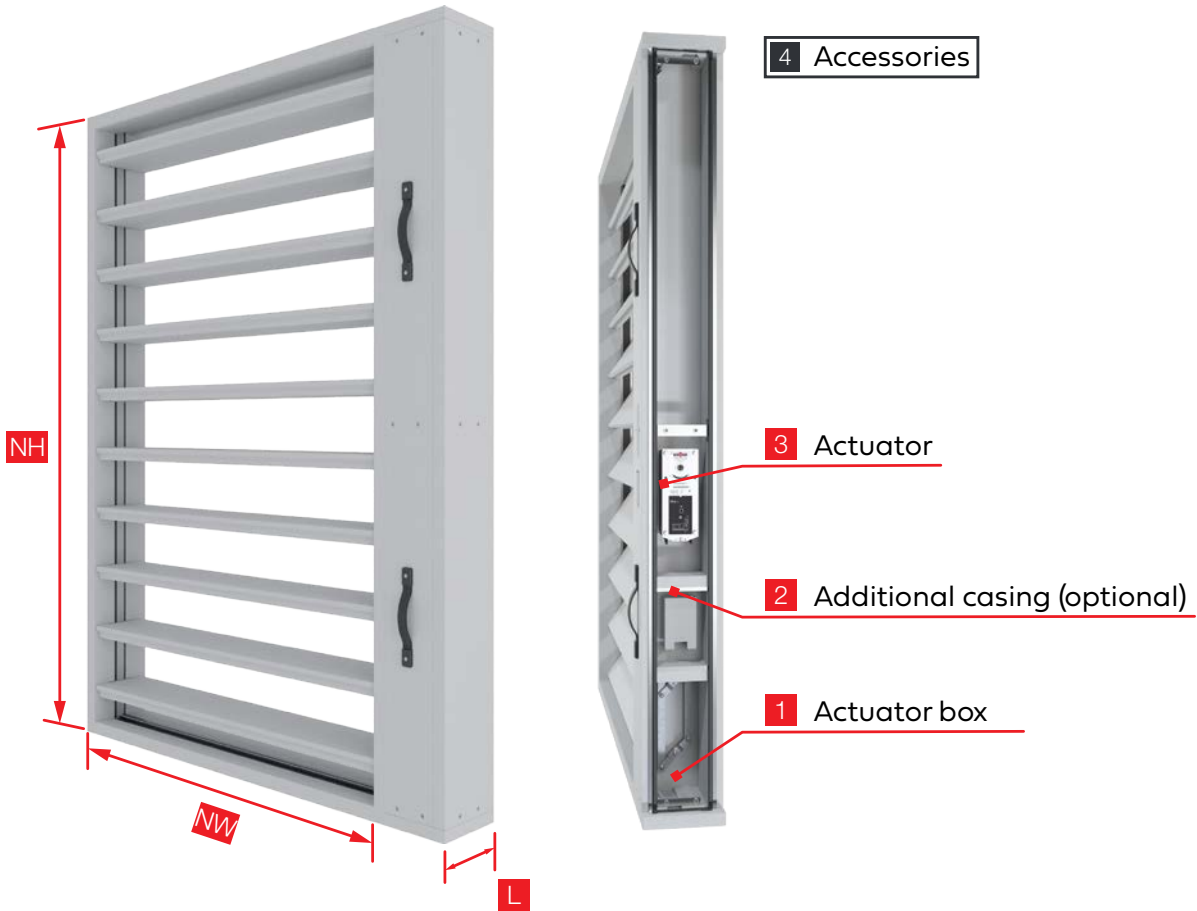

Dimensions

All widths and heights can be combined. Intermediate dimensions are possible within the specified increments.

Length (L):	220 mm (all sizes, without attachments)
Nominal width (NW):	200 ... 1200 mm, increments 50 mm
Nominal height (NH):	200 ... 2000 mm, increments 200 mm

For further information, see ► [Page 29](#).

1 Actuator box



Depending on the installation situation, the actuator box must be set up to accommodate front or side access. The handles included can be positioned accordingly on site!

Product

EKM90 smoke control damper

2 Additional casing (optional)

An installation space is available in the actuator box for installing the client's control units.

For EKM90 with $NH \geq 800$ mm, an optional additional casing can be provided ex works or as a retrofit.

For EKM90 with $NH \leq 600$ mm, a casing extension for additional installation space can only be provided at the factory.

For further information, see ▶ [Page 8](#) and ▶ [Page 29](#).

3 Actuator

M1 24V AC/DC
Reversible actuator
3 actuator sizes:
15 / 25 / 40 Nm

M2 230 V AC
Reversible actuator
3 actuator sizes
15 / 25 / 40 Nm

M3 24V AC/DC
Continuously variable
actuator
2 actuator sizes
15 / 25 Nm
Only up to $NH \leq 600$ mm

For further information, see ▶ [Page 35](#).

4 Accessories



Protective grille

For protecting the flow-through opening or as a closure
Optional accessories for on-site installation



A1 connecting frame

For installing the protective grille
Optional accessories for on-site installation



A2 connecting frame

For attaching/connecting smoke extraction ducts made of sheet steel or for installing the protective grille
Optional accessories for on-site installation



Support

Support for EKM90 in the installation opening
Included with the damper, for on-site installation



Terminal strip for actuators

For simplified connection of the electric actuators
Optional accessories for on-site installation



VK extension frame

For installing / connecting smoke extraction ducts made of calcium silicate
Optional accessories for on-site installation



Connecting seal

For installation in rigid ceilings and for use of the A1 connecting frame with protective grille
Optional accessories for on-site installation



Additional casing

For installing the client's control units
▪ For $NH \geq 800$ mm
Optional accessories for either on-site installation or pre-assembled installation at the factory

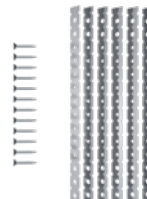

Wall anchor

For wet installation in walls and ceilings using mortar
Optional accessories for on-site installation



Handles for actuator box cover

Included with the damper, for on-site installation

For further information, see ▶ [Page 8](#).

Product description

EKM90 smoke control damper

3 Product description

The EKM90 smoke control damper is maintenance-free. Its design and the materials used, such as complete enclosure of the operation unit, mean that no routine maintenance is needed to keep it functioning properly. It does not require regular lubrication, for example. Servicing is therefore limited to functional checks (opening and closing the smoke control damper) or repairs in the event of damage. The functional checks are easy to carry out remotely thanks to the maintenance-free characteristics of these dampers.

The maintenance-free EKM90 smoke control damper is classified as:

- EI 90/120 ($v_{edw} - h_{odw} - i \leftrightarrow o$) S1000 C_{mod} HOT400/30 MA multi.

It complies with the European product standard EN 12101-8.

The multi-blade smoke control damper is designed for smoke extraction and ventilation on mechanical equipment, and is thus generally also used as a so-called "combi-damper". Also in pressurised ventilation systems and for secondary air flow. It is manufactured in sizes from 200 x 200 mm to 1200 x 2000 mm (NW x NH) and a length of 220 mm. It is suitable for flow rates of up to 155,520 m³.

The fire resistance tests were conducted in accordance with EN 1366-10 and EN 1366-2. The verified "MA" classification means that the smoke control dampers can still be opened after 25 minutes of full exposure to fire. Both automatic and manual activation are possible. Smoke extraction ducts and protective grilles may be connected.

The EKM90 smoke control damper also meets the HOT classification, which means that it closes and opens for at least 30 minutes when exposed to a 400°C fire.

3.1 Transportation protection

The factory-fitted transportation protection consists of central crossbars plus corner plates, which are fitted according to size. This protection remains on the casing to stabilise the damper until it is installed. Depending on the installation situation, the transportation protection can be removed on one side for installation. After the damper is installed and checked for functionality, the transportation protection including screws must be removed.

A Crossbar from nominal height NH \geq 1000 mm

B Corner plate: from nominal width NW \geq 1000 mm and nominal height NH \geq 1000 mm

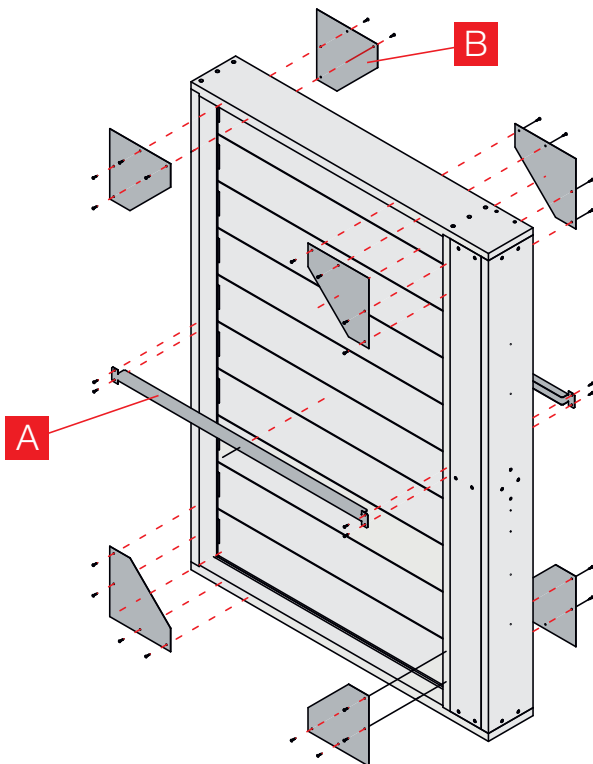

Notes:

The transportation protection must not be used as attachment/lifting points during transport.

If possible, leave the EKM90 on the transport pallet until it is at the installation site, and only take it off the pallet, using suitable lifting equipment, for installation in the opening.

Product description

EKM90 smoke control damper

3.2 Area of use

Overview of installation options

- In rigid walls, shaft walls and ceilings
 - In metal stud walls
 - On and in horizontal or vertical smoke extraction ducts*
 - lightweight shaft walls, with or without metal studs, clad on one side
- Wet installation using mortar or dry installation using mineral wool are possible

For further information, see ► [Page 18 ff.](#)

The following can be connected:

- Smoke extraction ducts* with fire resistance period on one or both sides
- Smoke extraction ducts without fire resistance period on one side
- Protective grille on one or both sides

* Smoke extraction ducts tested in accordance with EN 1366-8 and 1366-9 or with a general building authority test certificate (AbP)

3.3 Function

Maintenance / functional test

- Smoke extraction systems must be kept in good working order and maintained by the operator. The smoke control dampers should be tested for correct functioning at six-month intervals. If two successive tests are fault-free, the next test may be carried out after one year.
- Operating instructions for the EKM90 smoke control dampers are available on the Internet at www.wildeboer.de.
- In general, actuating (closing and opening) the smoke control dampers is sufficient for functional testing. This can be done remotely.
- EKM90 smoke control dampers are maintenance-free.
- Smoke extraction ducts require cleaning according to operating conditions, and this also includes smoke control dampers.

Product description

EKM90 smoke control damper

3.4 Accessories

3.4.1 Additional casing for NH ≥ 800 mm

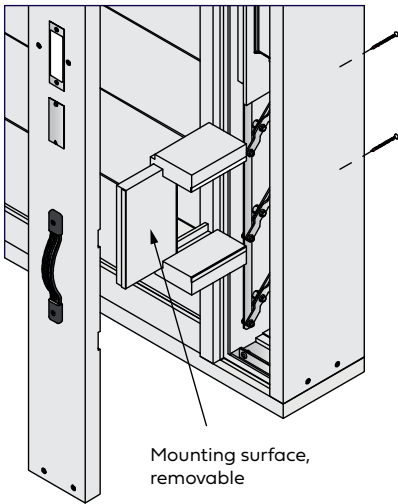

The optional additional casing, which is incorporated in the EKM90 actuator box, is used for installing the client's control units.

The additional casing serves as a mounting surface for installing control units.

The additional casing is fitted at the factory if ordered, or can be optionally retrofitted from a NH of ≥ 800 mm.

Installation space for control devices
(W x H x T) 140 x 200 x 80 mm

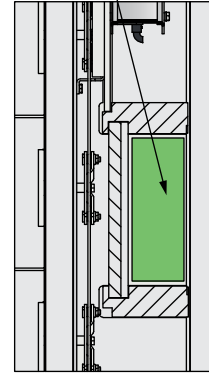

3.4.2 Casing extension for NH of ≤ 600 mm

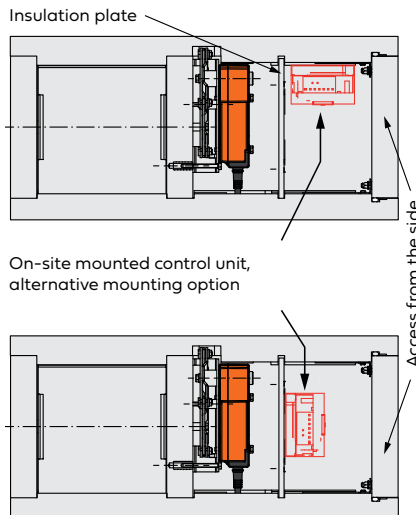

For installing client's control units, it is possible to order an optional casing extension of the actuator box up to NH of ≤ 600 mm ex works.

If access is only possible from the side: In this case, the insulating plate must be removed during installation in order to maintain accessibility to the actuator.

For further information, see [▶ Page 29](#).

Installation space for control devices (W x H x T)

NH200 = 130 x 150 x 120 mm

NH400 = 130 x 350 x 120 mm

NH600 = 130 x 550 x 120 mm

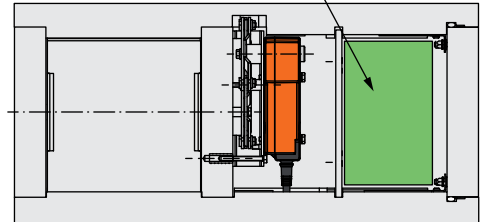

3.4.3 Terminal strip

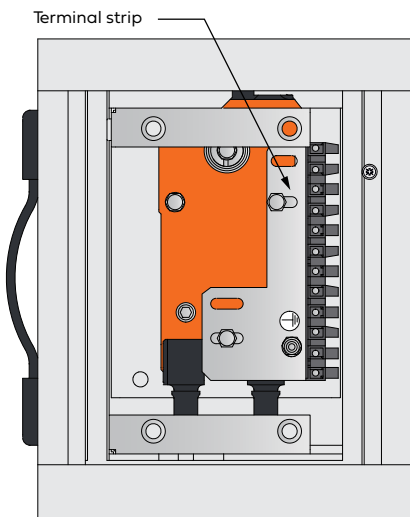

The terminal strip is used to simplify connection of electrical actuators and is mounted on the respective EKM90 actuator.

Product description

EKM90 smoke control damper

3.4.4 VK extension frame

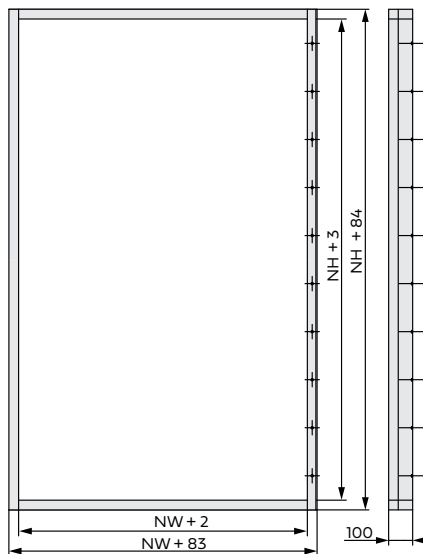
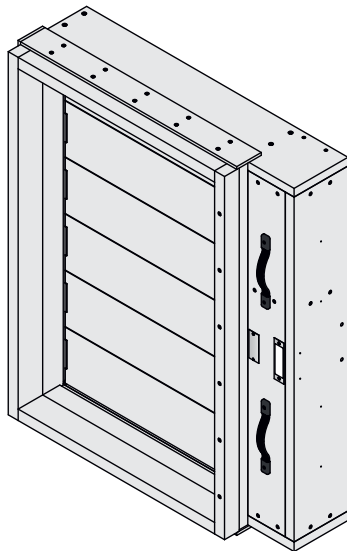

The VK extension frame, made of calcium silicate, is used for installing smoke extraction ducts made of construction board (e.g. Promat Promatect LS) with a fire resistance period.

3.4.5 A1 connecting frame

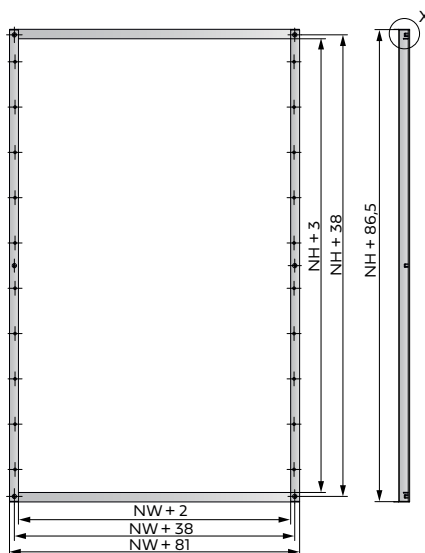
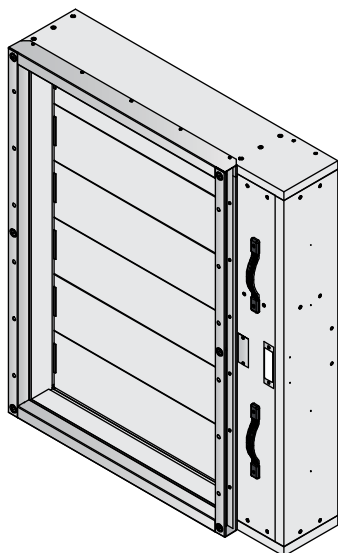

The A1 connecting frame, made of galvanised sheet steel, is used to install the protective grille. The connecting seal and screws for fastening are included.

3.4.6 A2 connecting frame

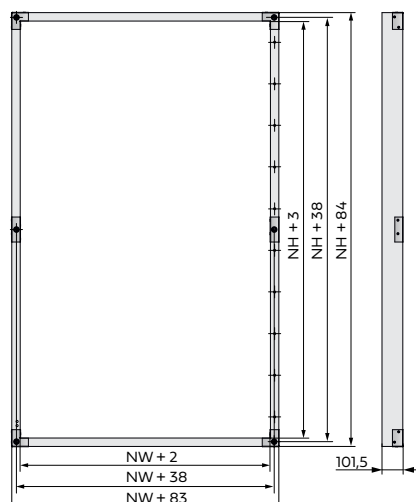
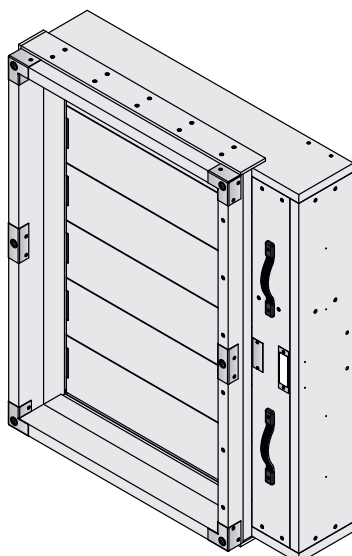

The A2 connecting frame made of calcium silicate is used for attachment to smoke extraction ducts made of sheet steel or for installing the protective grille. The screws and adhesive for fastening are included.

Product description

EKM90 smoke control damper

3.4.7 Protective grille

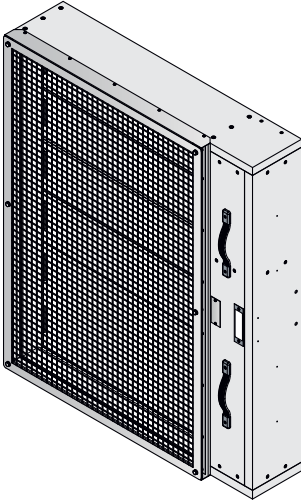

The protective grille is made of 1.5 mm thick galvanised sheet steel and has a mesh width of 20 mm.

The grille is installed on the A1 or A2 connecting frame using M10 screws.

3.4.8 Handles

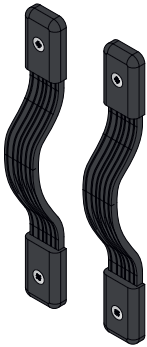

The EKM90 actuator box is accessible from the front or side, depending on the type of installation.

The handles for the actuator box cover are included and must be fitted according to the required accessibility.

The handles are supplied from the factory in 2 lengths, depending on the size of damper.

- Length = 187 mm
- Length = 254 mm

3.4.9 Connecting seal

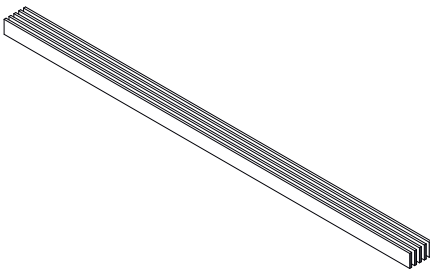

The connecting seal is used for the A1 connecting frame and for dry installation in rigid ceilings.

For ceiling installation, the required number of packs must be ordered separately, depending on the nominal height.

- NH < 1600 mm = 1 x pack of connecting seals
- NH \geq 1600 mm = 2 x packs of connecting seals

For further information, see ► [Page 25](#).

3.4.10 Wall anchor

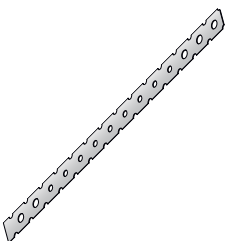

Wall anchors are used for wet installation in rigid walls and ceilings and must be ordered separately.

















The number of wall anchors required depends on the nominal height:

- NH < 1600 mm: 1 packs of wall anchors required
- NH \geq 1600 mm: 2 packs of wall anchors required









Installation overview

EKM90 smoke control damper

4 Installation overview

Construction	Thickness [mm]	Design	Type of installation	Installation	Classification:	Construction	Filling material	Details
Rigid wall / shaft wall	≥ 90	Brickwork Concrete Aerated concrete Lightweight concrete With a bulk density of ≥ 450 kg/m ³	Wet	In rigid walls	EI 120 (v _{ew} - i ↔ o)			Page 18
			Dry					Page 19
Metal stud wall	≥ 95	Metal stud wall clad on both sides with fire protection board type GKF - A2 (EN 520, DIN 18180) or equivalent, with or without the mineral wool filling of ≤ 100 kg/m ³	Wet	In metal stud wall	EI 90 (v _{ew} - i ↔ o)			Page 20
			Dry					Page 21
Lightweight shaft wall	≥ 90	Metal stud wall (at least 2 x 20 mm) clad on one side with fire protection board type GKF - A2 (EN 520, DIN 18180) or equivalent	Dry	In lightweight shaft wall	EI 120 (v _{ew} - i ↔ o)			Page 22
Rigid ceiling	≥ 100	Concrete Aerated concrete Lightweight concrete With a bulk density of ≥ 450 kg/m ³	Wet	In rigid ceilings	EI 120 (h _{ow} - i ↔ o)			Page 24
			Dry					Page 25
Smoke extraction duct with fire resistance	≥ 35	Fire protection boards made of calcium silicate with bulk density of ≥ 500 kg/m ³ e.g. Promat Promatect LS or equivalent	Adhesive	On smoke extraction duct with protective grille or between smoke extraction duct	EI 120 (v _{ed} - h _{od} - i ↔ o)			Page 26
Smoke extraction duct without fire resistance, made of sheet steel		According to manufacturer's specifications in accordance with DIN EN 12101-7 or with proof of usability in accordance with the MBO (Model Building Code)		Between or connected to smoke extraction ducts	EI 120 (v _{ed} - h _{od} - i ↔ o)		-	Page 26

Nomenclature

Construction	Filling material
 Rigid wall made of brickwork, concrete, aerated concrete or lightweight concrete with a bulk density of ≥ 450 kg/m ³	 Mineral wool of ≥ 100 kg/m ³ and melting point of 1,000 °C
 Metal stud wall clad on both sides with fire protection board type GKF - A2 (EN 520, DIN 18180) or equivalent	 Fire protection or gypsum mortar of Group II or III according to DIN 1053 or classes M2.5, M5, M10 or M20 according to EN 988-2
 Lightweight shaft wall designed as metal stud wall (min. 2 x 20 mm) clad on one side with fire protection board type GKF - A2 (EN 520, DIN 18180) or equivalent	 Adhesive: Promat "K84" or equivalent
 Concrete, aerated concrete, lightweight concrete with a bulk density of ≥ 450 kg/m ³	
 Smoke extraction duct with fire resistance	
 Smoke control damper without fire resistance according to manufacturer's specifications in accordance with DIN EN 12101-7 or with proof of usability in accordance with the MBO (Model Building Code)	

5 Installation

The EKM90 smoke control dampers must be installed and operated in accordance with this user manual and these operating instructions and in compliance with all other regulations. They must be installed free of stress. Installation can be with a horizontal or vertical shaft position.

Structural requirements and concerns must be verified and observed on site, as well as relevant manufacturer specifications.

- Smoke control dampers for outside air supply must be installed such that heavy moisture penetration is avoided, in particular in the event of frost exposure.
- Assembly, electrical wiring, connections etc. must be performed on site.
- Smoke extraction ducts being connected must be suitable, professionally installed, suspended and connected!
- Inspection openings must be provided on site in the smoke extraction ducts if necessary.
- Installation gaps and joints must be completely sealed in accordance with the fire resistance regulations.

5.1 Installation positions

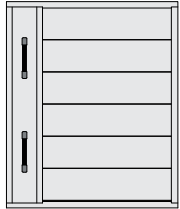
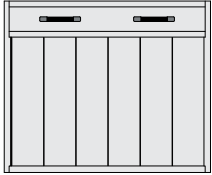
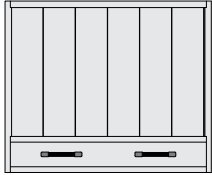
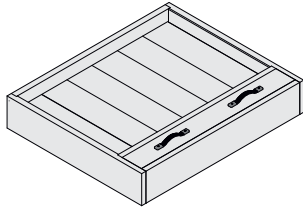
<p>Horizontal shaft position – actuator box on right</p> 	<p>Horizontal shaft position – actuator box on left</p> 
<p>Vertical shaft position – actuator box at top</p> 	<p>Vertical shaft position – plenum box at bottom</p> 
<p>with horizontal damper blade</p> 	

5.2 Installation openings: Dimensions and requirements

The dimensions of the installation openings differ for wet installation, dry installation and for the use of the EKM90 with casing extension.

5.2.1 Rigid walls

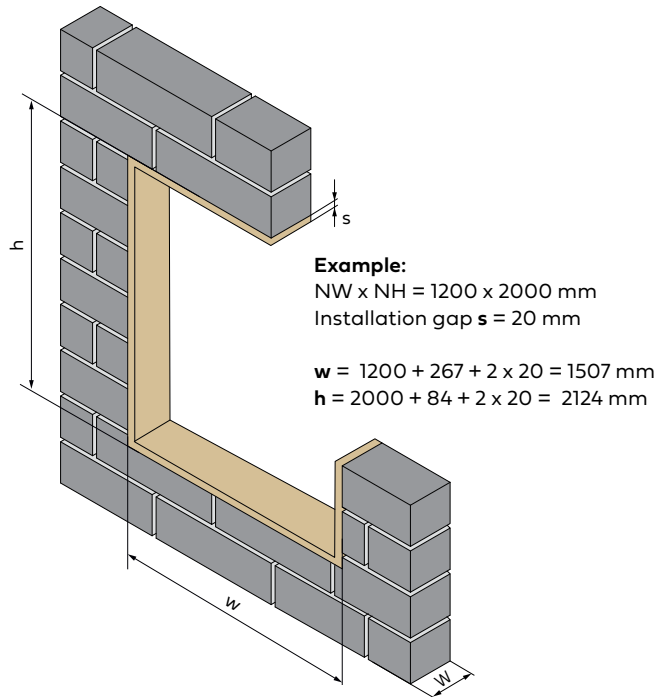

Wet installation:

- Rigid wall (W) ≥ 90 mm

$$w = NW + 267 + 2 \times s \text{ [mm]}$$

$$h = NH + 84 + 2 \times s \text{ [mm]}$$

With optional casing extension with NH of ≤ 600 mm:

$$w = NW + 400 + 2 \times s \text{ [mm]}$$

$$h = NH + 84 + 2 \times s \text{ [mm]}$$

For further information, see [▶ Page 29.](#)

Installation gap ≥ 8 mm $s \leq 50$ mm
 (recommended: 20 ... 40 mm)

For further information, see [▶ Page 18.](#)

Dry installation

- Rigid wall (W) ≥ 90 mm

$$w = NW + 267 + 2 \times s \text{ [mm]}$$

$$h = NH + 84 + 2 \times s \text{ [mm]}$$

With optional casing extension up to NH of ≤ 600 mm:

$$w = NW + 400 + 2 \times s \text{ [mm]}$$

$$h = NH + 84 + 2 \times s \text{ [mm]}$$

For further information, see [▶ Page 29.](#)

Installation gap $s \leq 15$ mm

For further information, see [▶ Page 19.](#)

5.2.2 Rigid ceilings

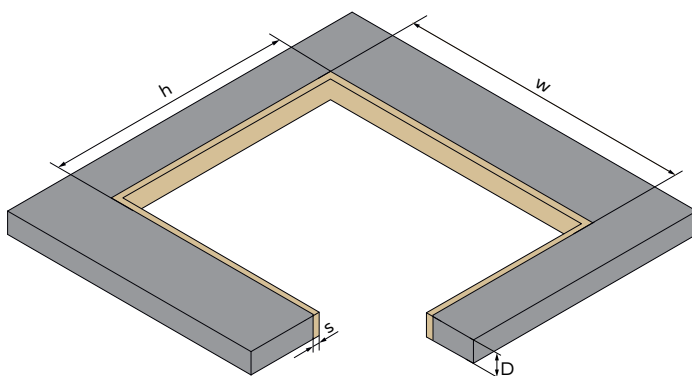

Wet installation:

- Rigid ceiling (D) ≥ 100 mm

$$w = NW + 267 + 2 \times s \text{ [mm]}$$

$$h = NH + 84 + 2 \times s \text{ [mm]}$$

With optional casing extension with NH of ≤ 600 mm:

$$w = NW + 400 + 2 \times s \text{ [mm]}$$

$$h = NH + 84 + 2 \times s \text{ [mm]}$$

For further information, see [▶ Page 29.](#)

Installation gap ≥ 8 mm $s \leq 50$ mm
 (recommended: 20 ... 40 mm)

For further information, see [▶ Page 24.](#)

Dry installation

- Rigid ceiling (D) ≥ 100 mm

$$w = NW + 267 + 2 \times s \text{ [mm]}$$

$$h = NH + 84 + 2 \times s \text{ [mm]}$$

With optional casing extension up to NH of ≤ 600 mm:

$$w = NW + 400 + 2 \times s \text{ [mm]}$$

$$h = NH + 84 + 2 \times s \text{ [mm]}$$

For further information, see [▶ Page 29.](#)

Installation gap $s \leq 15$ mm

For further information, see [▶ Page 24.](#)

5.2.3 Metal stud walls clad on both sides

Design and erect metal stud walls in accordance with the manufacturer's instructions for the respective application and the required fire resistance period.

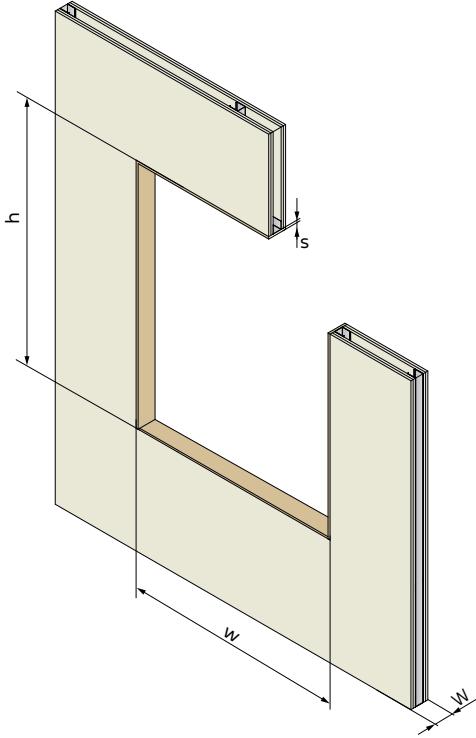

Wet installation:

- Metal stud wall (**W**) ≥ 95 mm

$$w = NW + 267 + 2 \times s \text{ [mm]}$$

$$h = NH + 84 + 2 \times s \text{ [mm]}$$

With optional casing extension up to NH of ≤ 600 mm:

$$w = NW + 400 + 2 \times s \text{ [mm]}$$

$$h = NH + 84 + 2 \times s \text{ [mm]}$$

For further information, see [▶ Page 29](#).

Installation gap ≥ 8 mm ≤ 50 mm

(recommended: 20 ... 40 mm)

For further information, see [▶ Page 20](#).

Dry installation

- Metal stud wall (**W**) ≥ 95 mm

$$w = NW + 267 + 2 \times s \text{ [mm]}$$

$$h = NH + 84 + 2 \times s \text{ [mm]}$$

With optional casing extension up to NH of ≤ 600 mm:

$$w = NW + 400 + 2 \times s \text{ [mm]}$$

$$h = NH + 84 + 2 \times s \text{ [mm]}$$

For further information, see [▶ Page 29](#).

Installation gap for dry installation $s \leq 15$ mm

For further information, see [▶ Page 21](#).

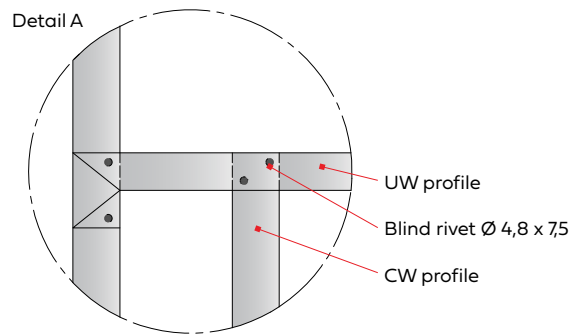
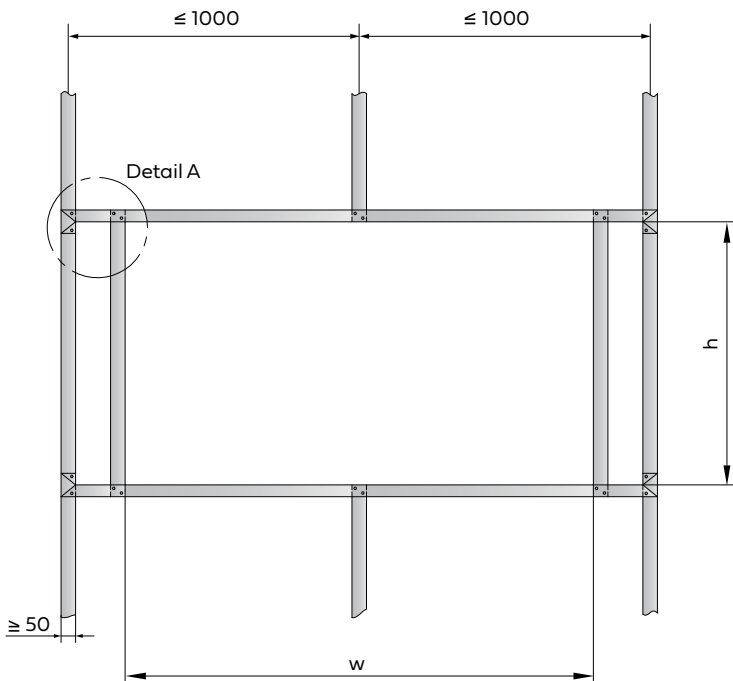

Installation

EKM90 smoke control damper

5.2.4 Lightweight shaft walls with metal stud frame and cladding on one side

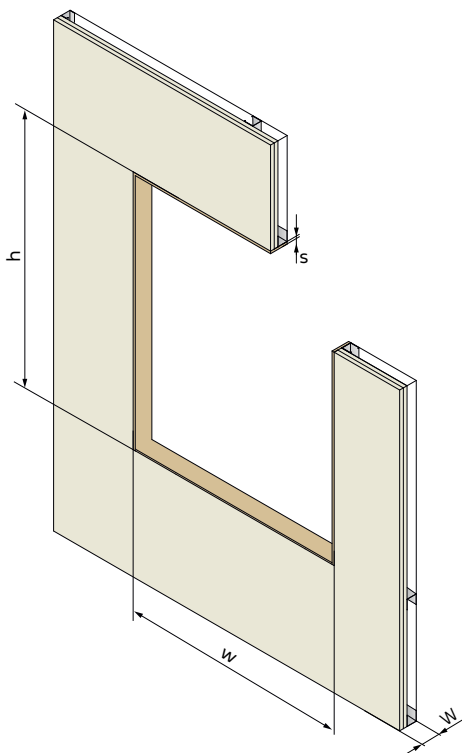

Dry installation

- Lightweight shaft wall (W) ≥ 90 mm

$$w = NW + 267 + 2 \times s \text{ [mm]}$$

$$h = NH + 84 + 2 \times s \text{ [mm]}$$

With optional casing extension up to NH of ≤ 600 mm:

$$w = NW + 400 + 2 \times s \text{ [mm]}$$

$$h = NH + 84 + 2 \times s \text{ [mm]}$$

For further information, see ▶ [Page 29](#).

Installation gap for dry installation $s \leq 15$ mm

For further information, see ▶ [Page 22](#).

Note:

The metal stud frame is erected in the same way as metal stud walls.

See ▶ [Page 14](#).

5.2.5 Smoke extraction ducts with fire resistance period

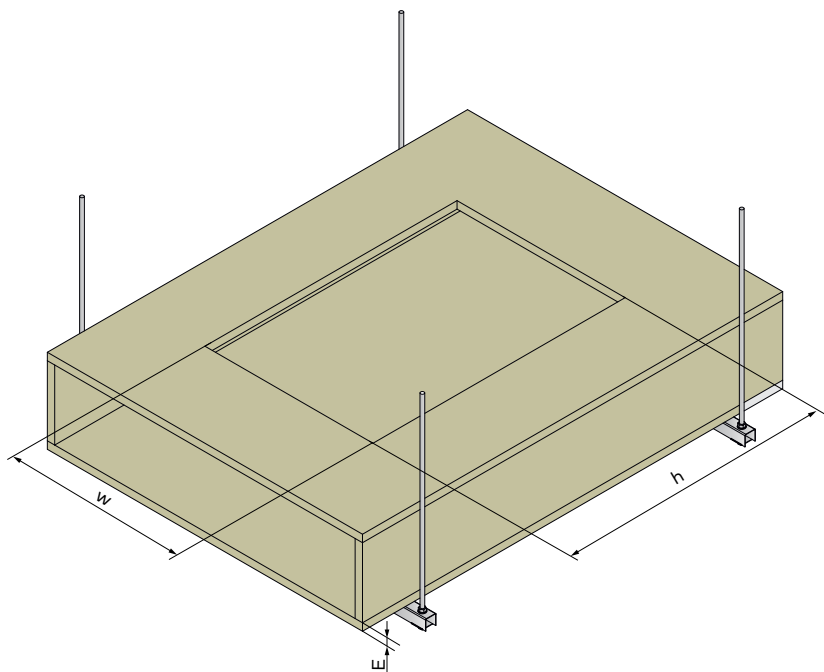

Dry installation

- Smoke extraction duct (E) ≥ 35 mm

$$w = NW + 2 (\pm 5) \text{ [mm]}$$

$$h = NH + 3 (\pm 5) \text{ [mm]}$$

Installation

EKM90 smoke control damper

5.3 Details of the installation work

The following details depend on the individual installation. Reference is made to this in the following installation chapters.

5.3.1 Installing supports

Depending on the wall thickness, the supports must be installed, for horizontal and vertical shaft positions. The supports must be aligned flush with the casing wall. To centre and align the smoke control damper, the supports in the installation opening can be replaced or lined with calcium silicate boards (Promatect H or similar).

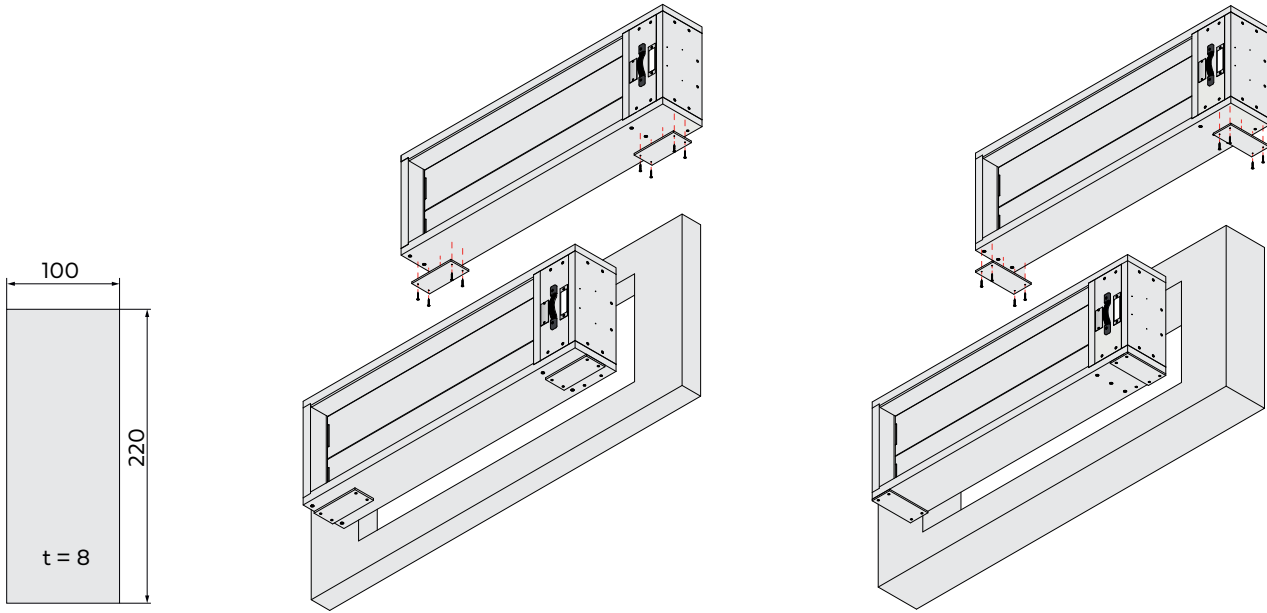

Dimensions

With wall thicknesses of ≤ 220 mm, the supports must be installed transversely aligned on the outer casing wall of the EKM90 and shortened if necessary.

With wall thicknesses of > 220 mm, the supports must be installed lengthways aligned on the outer casing wall of the EKM90 and shortened if necessary.

Note: Alternatively, the supports can also be placed in the installation opening and screwed to the wall.

5.3.2 Installing and gluing the strips

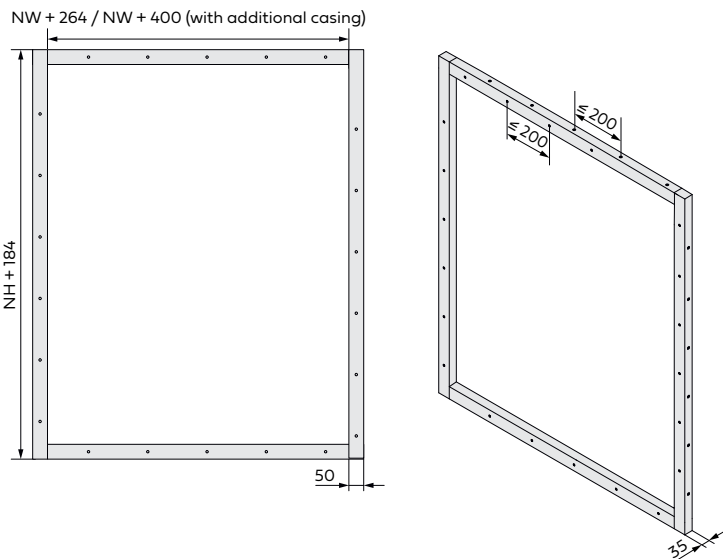

The 50 x 35 mm strips to be used for installation must be made of construction board (e.g. Promatect LS or equivalent). All connections must also be attached with a suitable adhesive (e.g. Promat K84 or equivalent) before screwing.

Note: Screw connection depends on the individual installation and is specified in the installation chapters. The strips must be pre-drilled before screwing. When using larger strip cross-sections ($\geq 50 \times \geq 35$ mm), the screw lengths must be adjusted accordingly!

Installation

EKM90 smoke control damper

5.3.3 Installing wall anchors

The wall anchors are installed all round the outside of the casing using the enclosed chipboard screws (4 x 35 mm). Wall anchors must be centred in the installation opening after the smoke control damper has been installed.

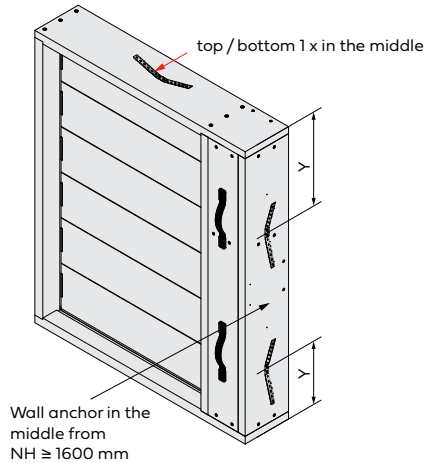

Nominal height (NH)	Spacing (Y)	Number of wall anchors
200 ... 600	NH/2	4
800 ... 1400	NH/4	6
1600 ... 2000	NH/4	8

5.3.4 Waterproofing and coating

The calcium silicate surfaces (interior and exterior) can be waterproofed on site using the following products:

- SR Impragnierung (Promat GmbH)
- Impragnierung 2000 (Promat GmbH)
- Tunnel-Impragnierung (Promat GmbH)

A standard emulsion paint of the desired colour can be used on the outer casing!

Note: Do not apply waterproofing agents to seals! Emulsion paints may only be used on the outer casing, markings and labels must not be coated!

5.3.5 Fire-resistant suspensions and attachments

Dimensioning of the tie rods according to DIN 4102-4.

Maximum permissible weights G on suspensions with steel threaded rods with a fire resistance period of 90 to 120 minutes:

Size	A _s [mm ²]	Weight load G [kg]	
		for 1 tie rod	for 1 pair
M8	36.6	22	44
M10	58.0	35	70
M12	84.3	52	104
M14	115	70	140
M16	157	96	192
M18	192	117	234
M20	245	150	300

A_s: Stress cross-section according to DIN 13

Notes:

- When dimensioning, the weights of the smoke control damper, attachments, crossbars, threaded rods and corresponding cladding must be taken into account.
- Tie rods of suspensions must fit as tightly as possible against the walls of the smoke extraction ducts or the casing of the smoke control dampers. Otherwise, they will need to be clad. This also applies to tie rods ≥ 1.5 m in length.
- Crossbars should be at least U50 according to DIN1026.
- Shims should be used as required.

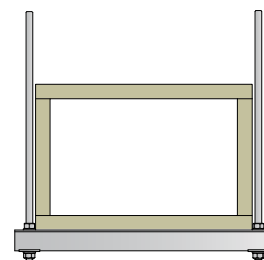

Fastening tie rods

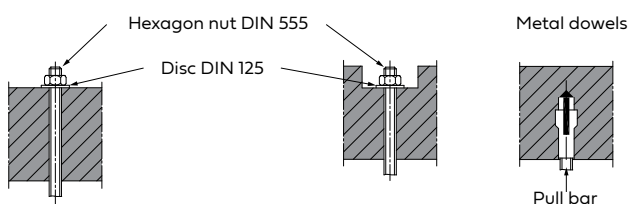

The anchors must be professionally installed, suitable for fire protection and approved.

Installation

EKM90 smoke control damper

5.4 Installation in rigid walls

5.4.1 Wet installation

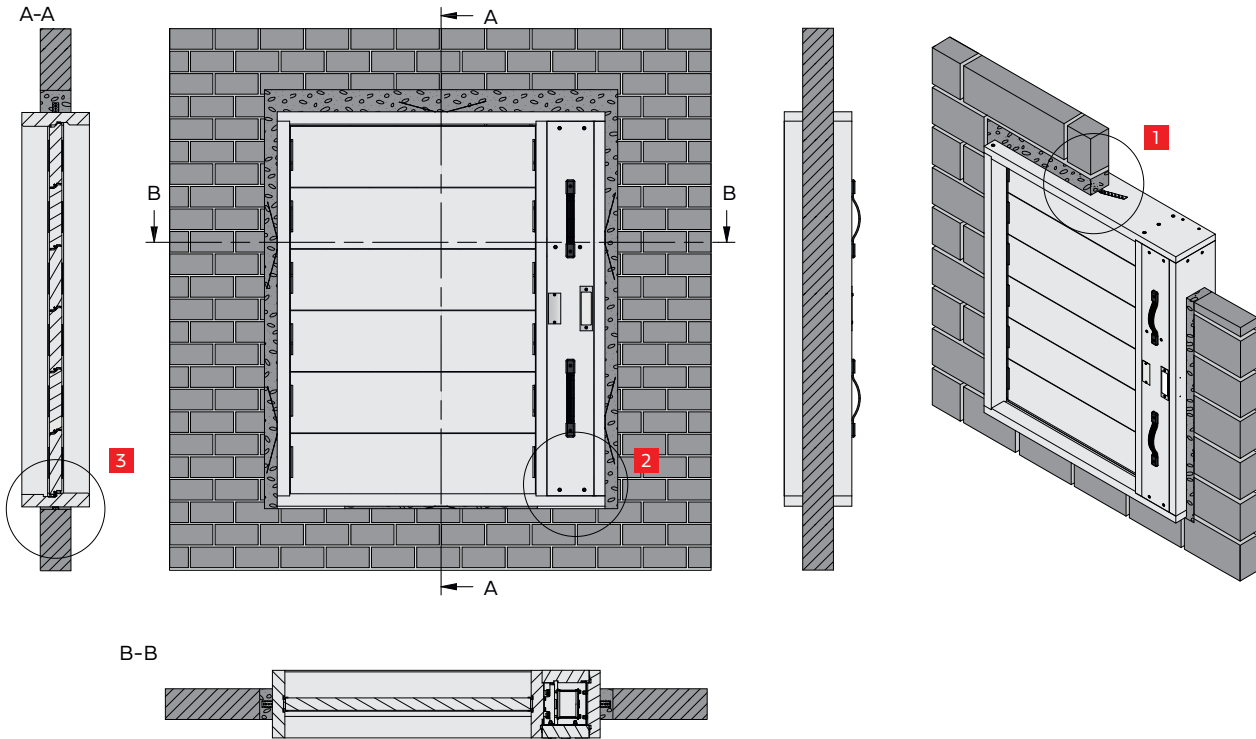

Make an installation opening

The required installation opening for rigid walls ▶ [Page 13](#) must be determined using the dimensions of the EKM90 versions.

Wall anchor

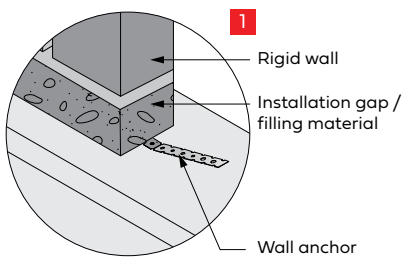

The position and number of wall anchors depends on the dimensions of the EKM90. Wall anchors must be screwed to the EKM casing centrally. For details, see ▶ [Page 17](#).

Support

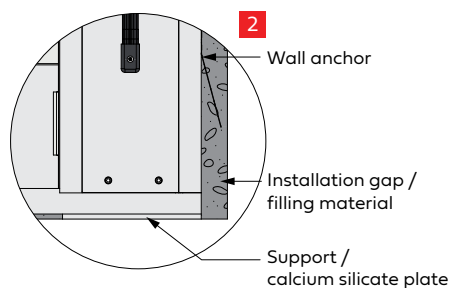

Depending on the wall thickness, the supports must be installed below the smoke control damper or screwed into the installation opening. To centre and align the smoke control damper, the supports can be replaced or lined with calcium silicate boards (Promatect H or similar). For details, see ▶ [Page 16](#).

Gap filling

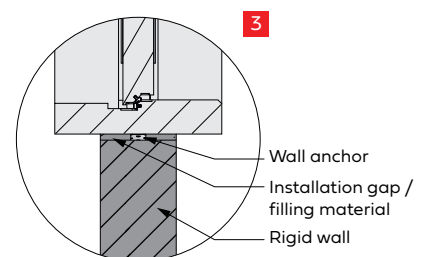

The EKM90 must be installed centrally (± 10 mm) in the wall and the installation gap filled with fire protection mortar or gypsum mortar from Group II or III in accordance with DIN 1053 or classes M2.5, M5, M10 or M20 in accordance with EN 988-2.

Flush wall installation for wall thicknesses ≥ 150 mm

For wet installation in walls ≥ 150 mm, the EKM90 can be installed flush with the wall. The wall anchors attached to the casing must then be centred (± 10 mm) in the installation opening. For details, see ▶ [Page 17](#).

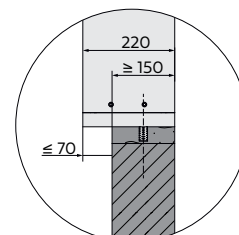

Installation

EKM90 smoke control damper

5.4.2 Dry installation

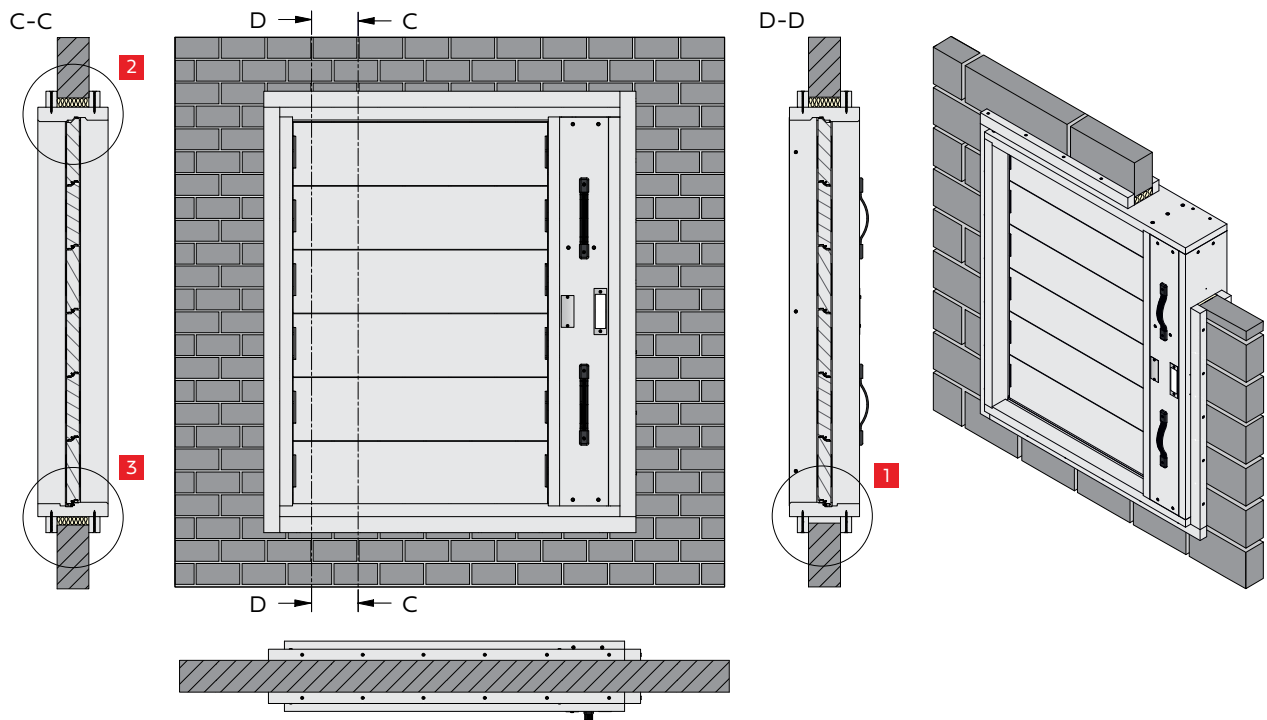

Make an installation opening

The required installation opening for rigid walls ▶ [Page 13](#) must be determined using the dimensions of the EKM90 versions.

Support

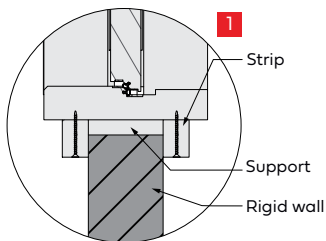

Depending on the wall thickness, the supports must be installed below the smoke control damper or screwed into the installation opening.

For details, see ▶ [Page 16](#).

Strips

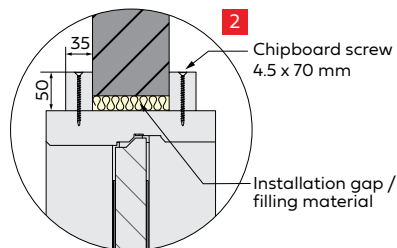

The strips must be screwed to the EKM90 all the way round on both sides using chipboard screws 4.5 x 70 mm and glued. For details, see ▶ [Page 16](#).

Gap filling

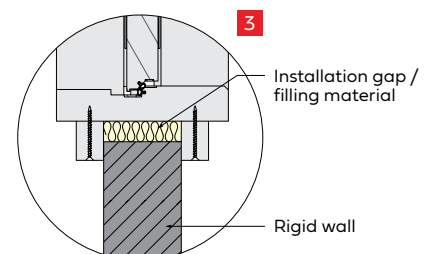

The EKM90 must be inserted centrally in (± 10 mm) of the wall and the installation gap filled with mineral wool ≥ 100 kg/ m³ and a melting point of 1,000°C.

Installation

EKM90 smoke control damper

5.5 Installation in metal stud walls

5.5.1 Wet installation

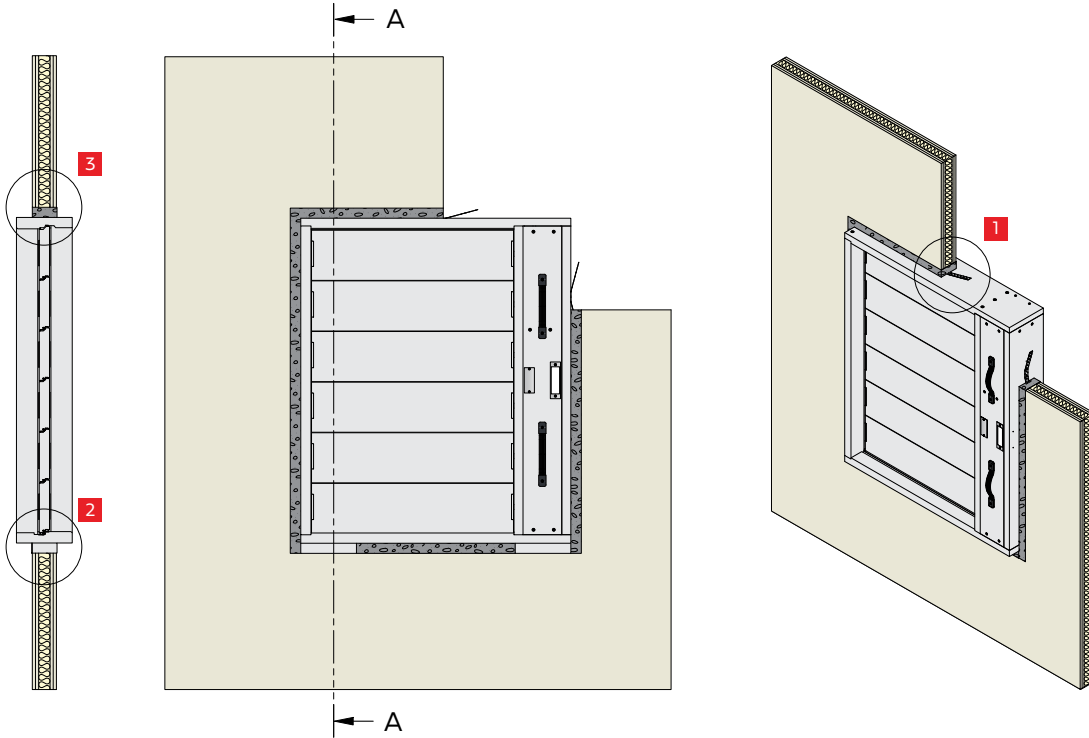

Make an installation opening

The required installation opening for metal stud walls ▶ [Page 14](#) must be determined using the dimensions of the EKM90 versions.

Wall anchor

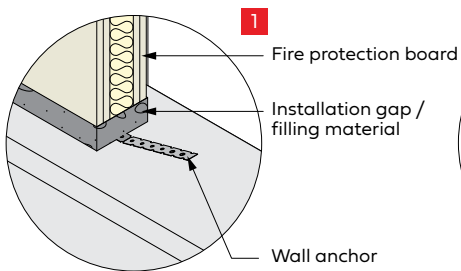

The position and number of wall anchors depends on the dimensions of the EKM90. Wall anchors must be screwed to the EKM casing centrally. For details, see ▶ [Page 17](#).

Support

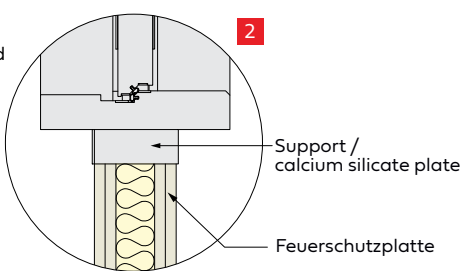

Depending on the wall thickness, the supports must be installed below the smoke control damper or screwed into the installation opening. To centre and align the smoke control damper, the supports can be replaced or lined with calcium silicate boards (Promatect H or similar).

For details, see ▶ [Page 16](#).

Gap filling

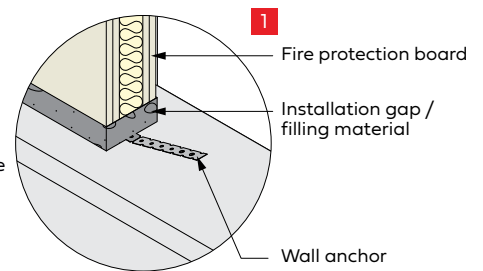

The EKM90 must be installed centrally (± 10 mm) in the wall and the installation gap filled with fire protection mortar or gypsum mortar from Group II or III in accordance with DIN 1053 or classes M2.5, M5, M10 or M20 in accordance with EN 988-2.

Installation

EKM90 smoke control damper

5.5.2 Dry installation

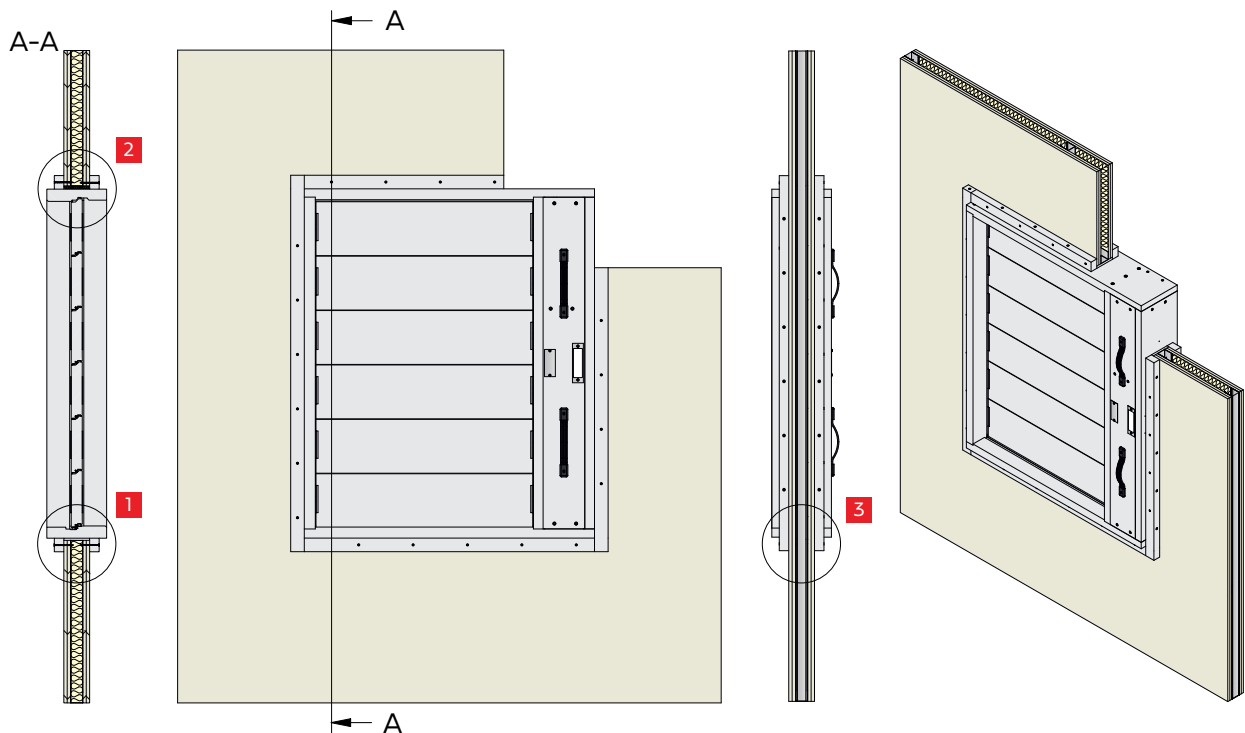

Make an installation opening

The required installation opening for metal stud walls ▶ [Page 14](#) must be determined using the dimensions of the EKM90 versions.

Support

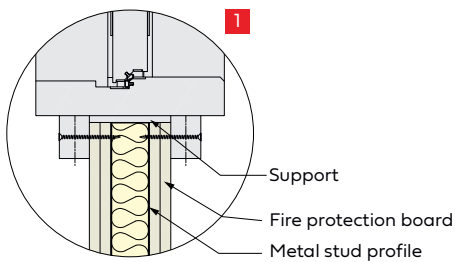

Support
Fire protection board
Metal stud profile

Depending on the wall thickness, the supports must be installed below the smoke control damper or screwed into the installation opening.

For details, see ▶ [Page 16](#).

Strips

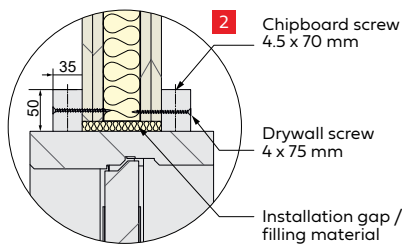

Chipboard screw
4.5 x 70 mm
Drywall screw
4 x 75 mm
Installation gap /
filling material

The strips must be screwed to the EKM90 all round on both sides using chipboard screws 4.5 x 70 mm and to the wall using drywall screws 4 x 75 mm and glued.

For details, see ▶ [Page 16](#).

Gap filling

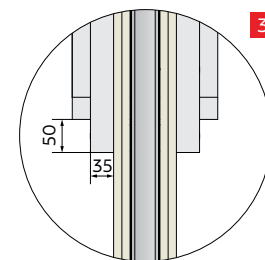

The EKM90 must be inserted centrally (± 10 mm) in the wall and the installation gap filled with mineral wool ≥ 100 kg/ m³ and a melting point of 1,000°C.

Installation

EKM90 smoke control damper

5.6 Installation in lightweight shaft wall

5.6.1 Dry installation

Centrally in the shaft wall

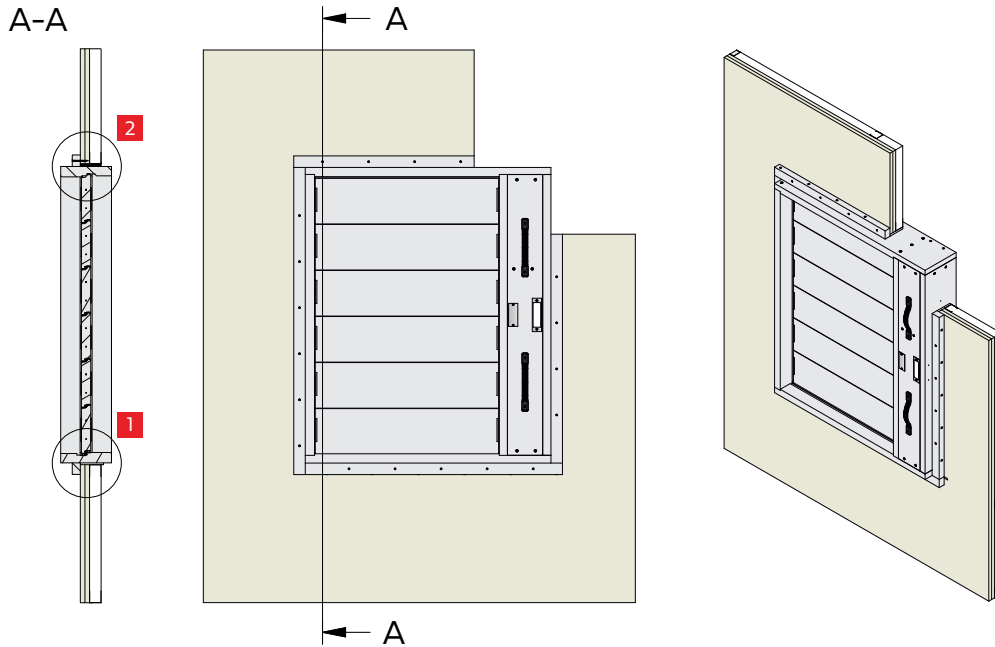

Make an installation opening

The required installation opening for lightweight shaft walls ▶ [Page 15](#) must be determined using the dimensions of the EKM90 versions.

Support

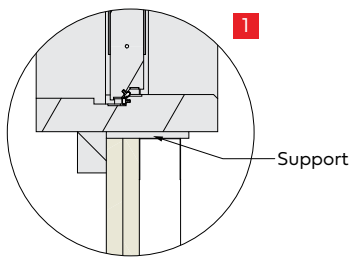

Depending on the wall thickness, the supports must be installed below the smoke control damper or screwed into the installation opening.

For details, see ▶ [Page 16](#).

Strips

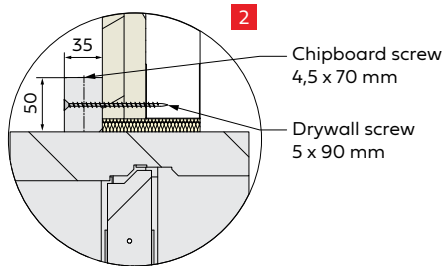

The strips must be screwed to the EKM90 all round on one side using chipboard screws 4.5 x 70 mm and to the wall using drywall screws 5 x 90 mm and glued.

For details, see ▶ [Page 16](#).

Gap filling

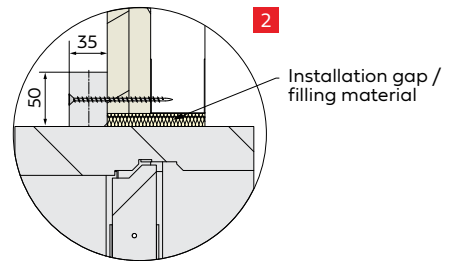

The EKM90 must be inserted centrally (± 10 mm) in the wall and the installation gap filled with mineral wool ≥ 100 kg/m³ and a melting point of 1,000°C.

Example with a wall thickness of 90 mm.

Installation

EKM90 smoke control damper

Possible positioning in the shaft wall with flush strips

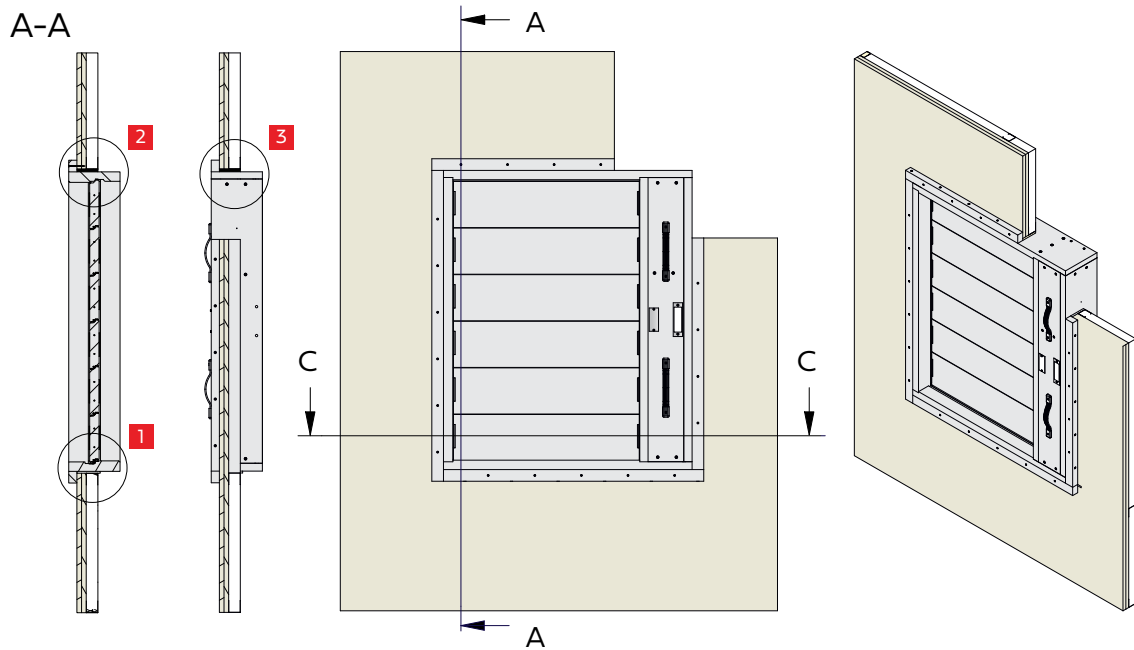

Support

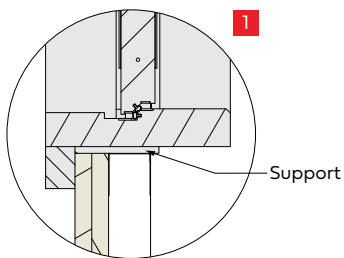

Depending on the wall thickness, the supports must be installed below the smoke control damper or screwed into the installation opening.

For details, see ► [Page 16](#).

Strips

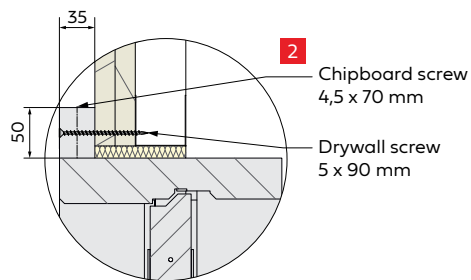

The strips must be screwed to the EKM90 all round on one side using chipboard screws 4.5 x 70 mm and to the wall using drywall screws 5 x 90 mm and glued.

For details, see ► [Page 16](#).

Gap filling

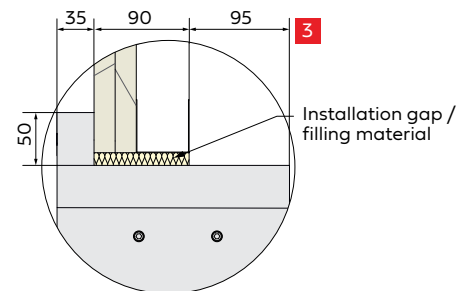

The EKM90 must be installed in the wall as shown and the installation gap filled with mineral wool $\geq 100 \text{ kg/m}^3$ and a melting point of $1,000^\circ\text{C}$.

Example with a wall thickness of 90 mm.

Installation

EKM90 smoke control damper

5.7 Installation in rigid ceilings

5.7.1 Wet installation

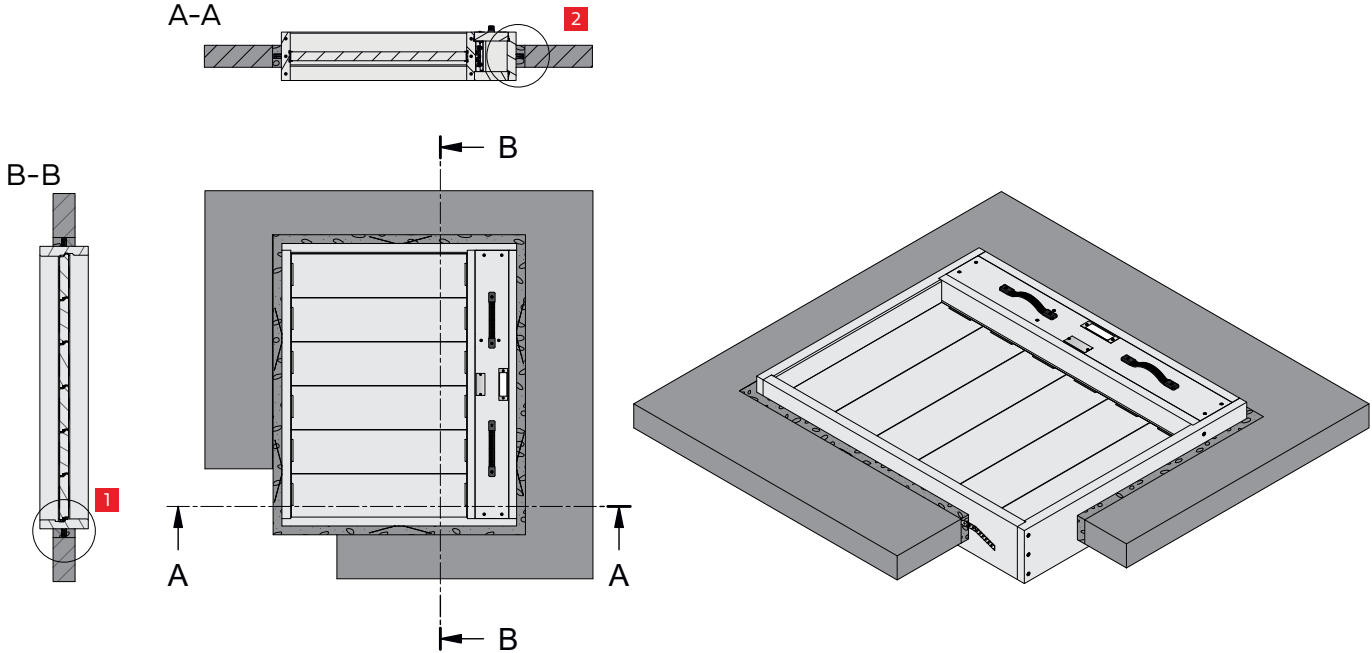

Make an installation opening

The required installation opening for rigid ceilings ▶ [Page 13](#) must be determined using the dimensions of the EKM90 versions.

Wall anchor

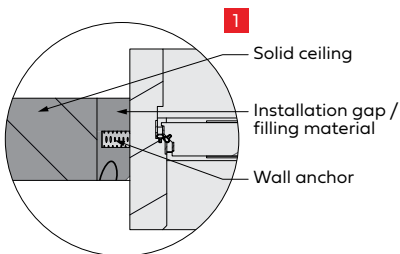

The position and number of wall anchors depends on the dimensions of the EKM90. Wall anchors must be screwed to the EKM casing centrally. For details, see ▶ [Page 17](#).

Gap filling

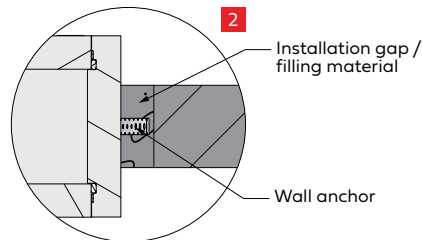

The EKM90 must be installed centrally (± 10 mm) in the ceiling and the installation gap filled with fire protection mortar or gypsum mortar from Group II or III in accordance with DIN 1053 or classes M2.5, M5, M10 or M20 in accordance with EN 988-2. Mortar anchors must be provided as required to connect the mortar in the installation opening on site!

Note:

For installation openings with gap widths of ≤ 25 mm, additional strips can be fitted as an installation aid at the top/bottom or on both sides in addition to filling the installation gap. The EKM90 must be properly supported and secured for installation.

Installation

EKM90 smoke control damper

5.7.2 Dry installation

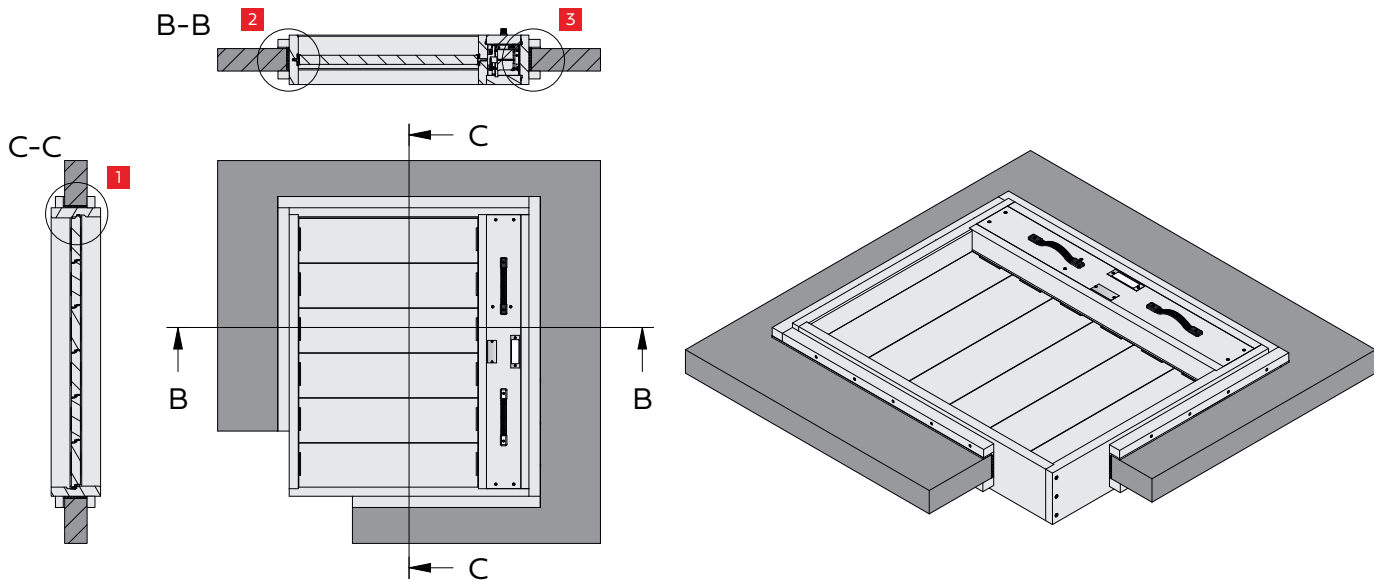

Make an installation opening

The required installation opening for rigid ceilings ▶ [Page 13](#) must be determined using the dimensions of the EKM90 versions.

Strips

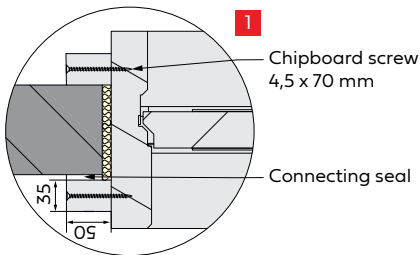

The strips must be screwed to the EKM90 all the way round on both sides using chipboard screws 4.5 x 70 mm and glued. For details, see ▶ [Page 16](#).

Connecting seal

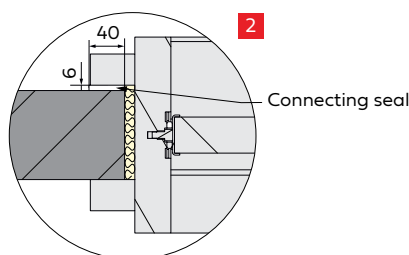

The number of connection seals to be fitted to the ceiling depends on the nominal height. For details, see the enclosed installation instructions for the connecting seal.

Gap filling

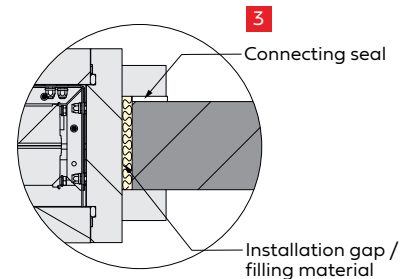

The EKM90 must be inserted centrally (± 10 mm) in the ceiling and the installation gap filled with mineral wool ≥ 100 kg/ m³ and a melting point of 1,000°C. Example with 100 mm ceiling.

Installation

EKM90 smoke control damper

5.8 Connection to smoke extraction duct

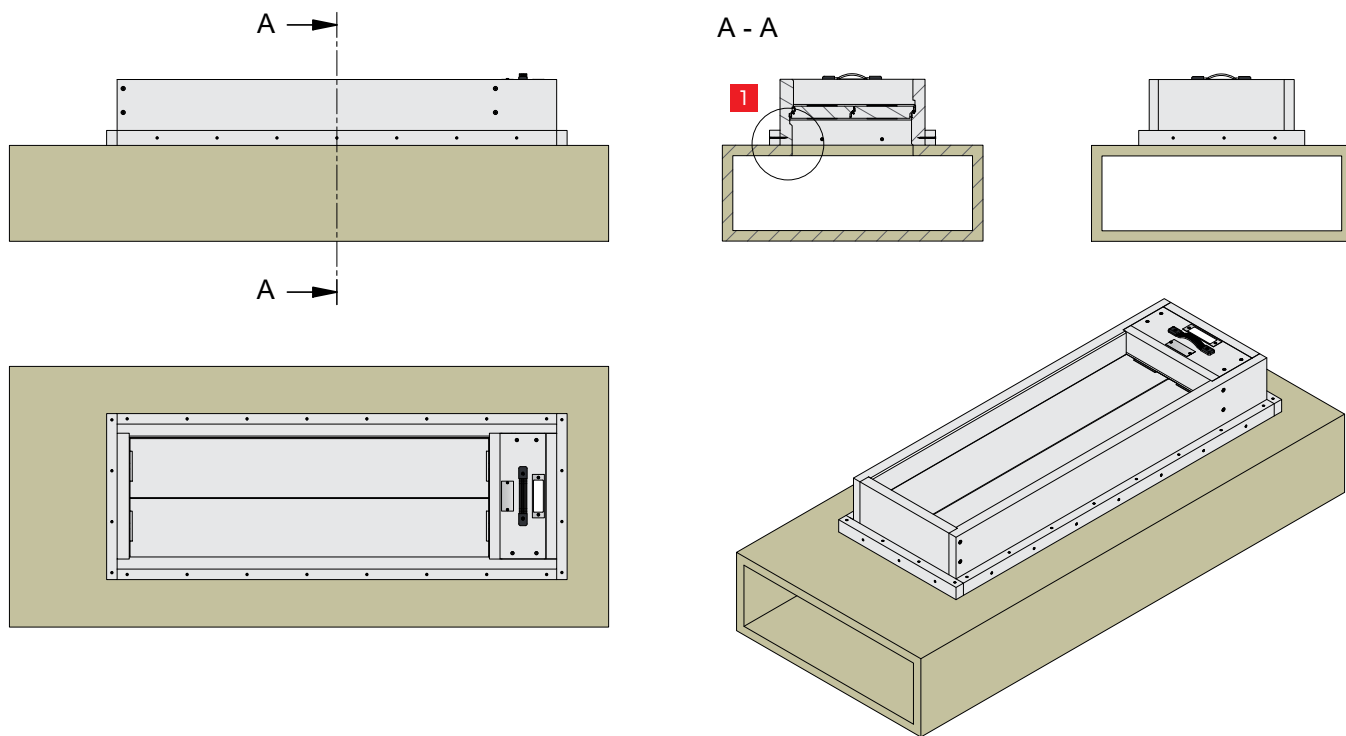

Make an installation opening

The required installation opening for smoke extraction ducts ▶ [Page 15](#) must be determined using the dimensions of the EKM90 versions.

Strips

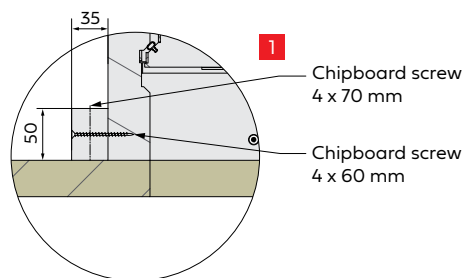

The strips must be screwed to the EKM90 all round on one side using 4 x 60 mm chipboard screws and to the smoke extraction duct using 4 x 70 mm chipboard screws and glued.

For details, see ▶ [Page 16](#).

For details on the suspension, see ▶ [Page 17](#).

Installation

EKM90 smoke control damper

Installation example: Flush installation with excess length

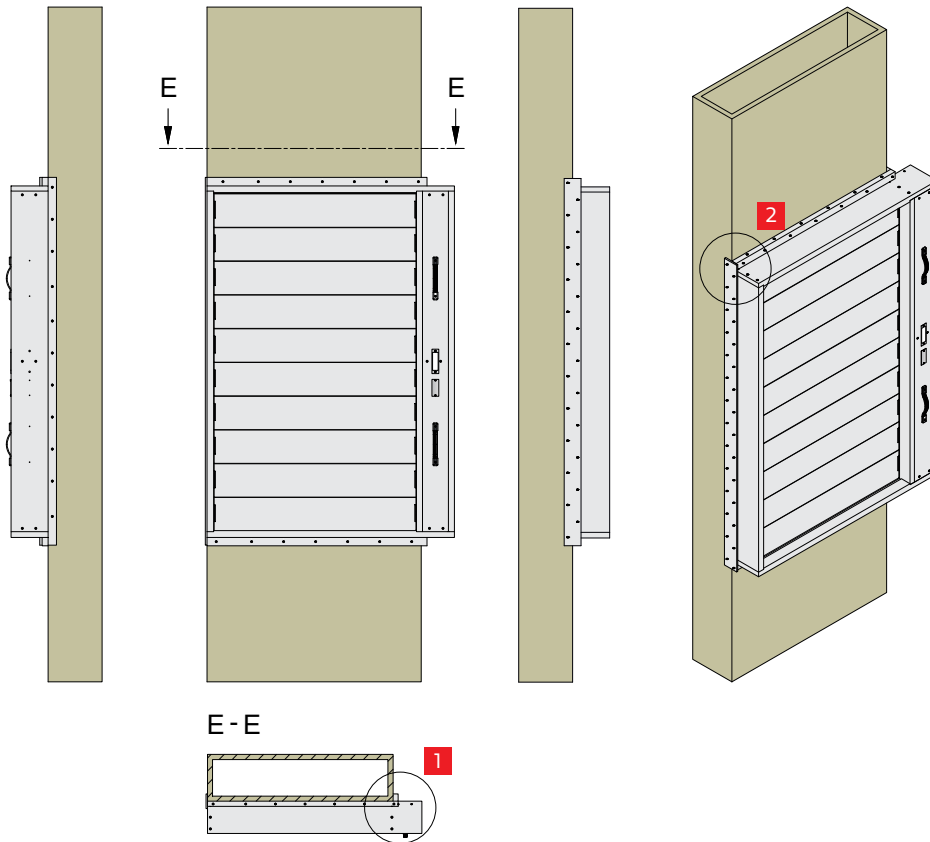

Strips

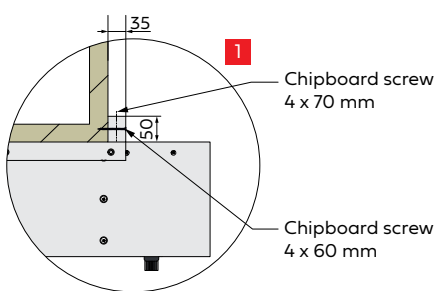

The strips must be screwed to the EKM90 all round on one side using 4 x 70 mm chipboard screws and to the smoke extraction duct using 4 x 60 mm chipboard screws and glued.

For details, see ► [Page 16](#).

For details on the suspension, see ► [Page 17](#).

Capping strips

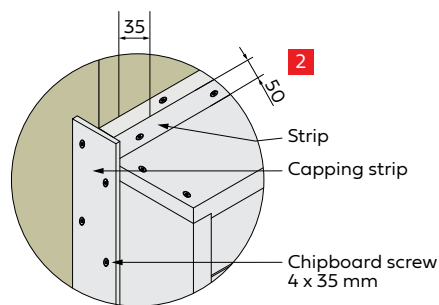

Screw the flashing strip to the EKM90 and the smoke extraction duct using 4 x 35 mm chipboard screws and apply glue.

For details, see ► [Page 16](#).

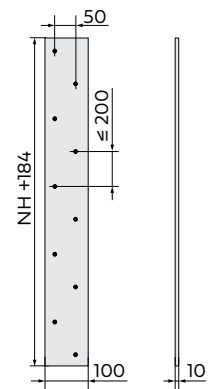

The length of the capping strip depends on the nominal height of the EKM90. The capping strip must be made of construction board (e.g. Promatect H or equivalent).

Installation

EKM90 smoke control damper

Installation example

Connection to smoke extraction duct made of construction board and fitted protective grille.

Accessories: A1 connecting frame*, protective grille
Accessibility to the actuator box: front / side

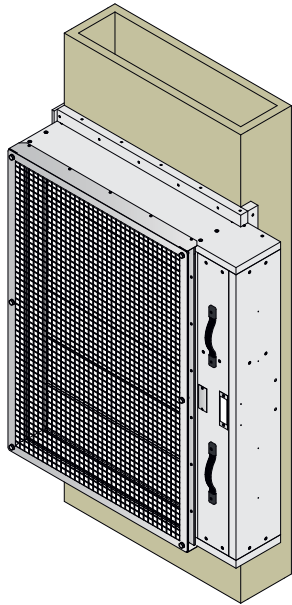

Double-sided connection to smoke extraction ducts made of Construction board.

Accessories: VK extension frame*
Accessibility to the actuator box: front / side

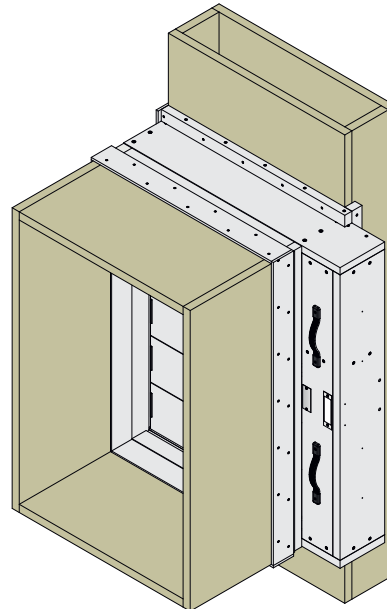

Double-sided connection to smoke extraction ducts made of construction board with all-round strips and suspension.

Accessories: VK extension frame* (2x)
Accessibility to the actuator box: side

For details on suspension, see ► [Page 17](#).

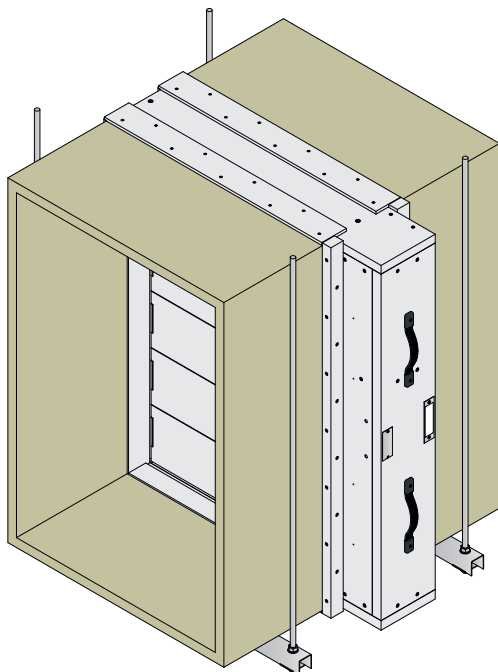

Connection to smoke extraction duct made of sheet steel and to smoke extraction duct made of construction board

Accessories: A2 extension frame*, VK extension frame*
Accessibility to the actuator box: side

For details on suspension, see ► [Page 17](#).

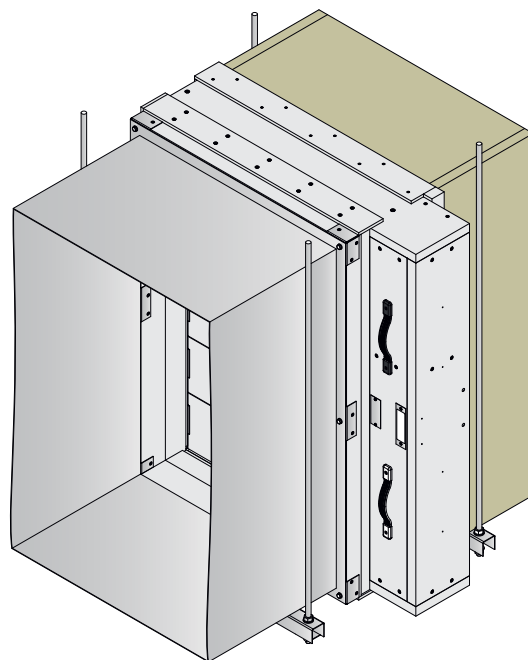

* For installation details, see the enclosed installation instructions.

Technical data

EKM90 smoke control damper

6 Technical data

6.1 Dimensions

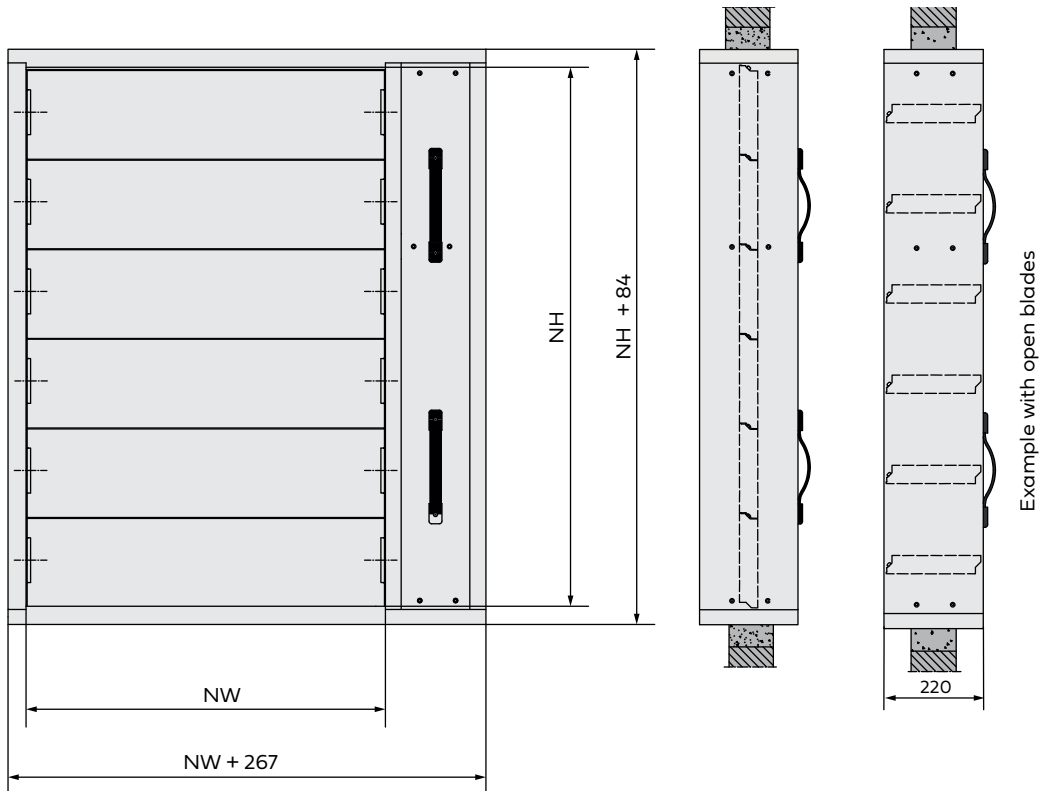

With casing extension for NH of ≤ 600 mm

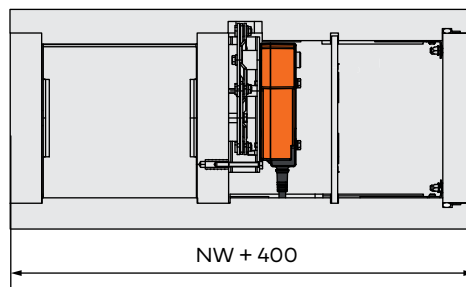

Technical data

EKM90 smoke control damper

6.2 Free cross-sections

Free cross-sections of the smoke control damper (in m²)

		Width [mm]																				
		200	250	300	350	400	450	500	550	600	650	700	750	800	850	900	950	1000	1050	1100	1150	1200
Height [mm]	200	0.032	0.040	0.047	0.055	0.063	0.071	0.079	0.087	0.095	0.103	0.111	0.119	0.126	0.134	0.142	0.150	0.158	0.166	0.174	0.182	0.190
	400	0.064	0.079	0.095	0.111	0.127	0.143	0.159	0.175	0.191	0.206	0.222	0.238	0.254	0.270	0.286	0.302	0.318	0.333	0.349	0.365	0.381
	600	0.095	0.119	0.143	0.167	0.191	0.215	0.239	0.262	0.286	0.310	0.334	0.358	0.382	0.405	0.429	0.453	0.477	0.501	0.525	0.549	0.572
	800	0.127	0.159	0.191	0.223	0.255	0.286	0.318	0.350	0.382	0.414	0.446	0.477	0.509	0.541	0.573	0.605	0.637	0.668	0.700	0.732	0.764
	1000	0.159	0.199	0.239	0.279	0.318	0.358	0.398	0.438	0.478	0.517	0.557	0.597	0.637	0.677	0.716	0.756	0.796	0.836	0.876	0.915	0.955
	1200	0.191	0.239	0.287	0.334	0.382	0.430	0.478	0.526	0.573	0.621	0.669	0.717	0.764	0.812	0.860	0.908	0.956	1.003	1.051	1.099	1.147
	1400	0.223	0.279	0.335	0.390	0.446	0.502	0.558	0.613	0.669	0.725	0.781	0.836	0.892	0.948	1.004	1.059	1.115	1.171	1.227	1.282	1.338
	1600	0.255	0.319	0.382	0.446	0.510	0.574	0.637	0.701	0.765	0.828	0.892	0.956	1.020	1.083	1.147	1.211	1.275	1.338	1.402	1.466	1.529
	1800	0.287	0.359	0.430	0.502	0.574	0.645	0.717	0.789	0.860	0.932	1.004	1.076	1.147	1.219	1.291	1.362	1.434	1.506	1.577	1.649	1.721
	2000	0.319	0.398	0.478	0.558	0.637	0.717	0.797	0.876	0.956	1.036	1.115	1.195	1.275	1.354	1.434	1.514	1.594	1.673	1.753	1.833	1.912

Free cross-sections of the smoke control damper with protective grille (in m²)

		Width [mm]																				
		200	250	300	350	400	450	500	550	600	650	700	750	800	850	900	950	1000	1050	1100	1150	1200
Height [mm]	200	0.024	0.029	0.037	0.040	0.049	0.054	0.059	0.064	0.073	0.078	0.083	0.088	0.094	0.102	0.108	0.113	0.118	0.123	0.132	0.137	0.146
	400	0.049	0.059	0.069	0.080	0.097	0.108	0.118	0.128	0.146	0.156	0.167	0.177	0.187	0.205	0.215	0.225	0.236	0.246	0.264	0.274	0.292
	600	0.073	0.088	0.104	0.119	0.146	0.161	0.177	0.192	0.219	0.234	0.250	0.265	0.281	0.307	0.323	0.338	0.354	0.369	0.396	0.411	0.437
	800	0.097	0.118	0.139	0.159	0.194	0.215	0.236	0.257	0.292	0.312	0.333	0.354	0.374	0.410	0.430	0.451	0.472	0.492	0.527	0.548	0.583
	1000	0.122	0.147	0.173	0.199	0.243	0.269	0.295	0.321	0.365	0.390	0.416	0.594	0.468	0.512	0.538	0.564	0.590	0.615	0.659	0.685	0.729
	1200	0.146	0.177	0.220	0.239	0.292	0.323	0.354	0.385	0.437	0.468	0.500	0.531	0.562	0.614	0.645	0.676	0.707	0.738	0.791	0.822	0.875
	1400	0.170	0.206	0.243	0.279	0.340	0.376	0.413	0.449	0.510	0.547	0.583	0.619	0.655	0.717	0.753	0.789	0.825	0.862	0.923	0.959	1.021
	1600	0.194	0.236	0.277	0.319	0.389	0.430	0.472	0.513	0.583	0.625	0.666	0.707	0.749	0.819	0.860	0.902	0.943	0.985	1.055	1.096	1.166
	1800	0.219	0.265	0.312	0.358	0.437	0.484	0.531	0.577	0.656	0.703	0.749	0.796	0.842	0.921	0.968	1.015	1.061	1.108	1.187	1.233	1.312
	2000	0.243	0.295	0.347	0.398	0.486	0.538	0.590	0.641	0.729	0.781	0.833	0.884	0.936	1.024	1.076	1.127	1.179	1.231	1.319	1.370	1.458

Technical data

EKM90 smoke control damper

6.3 Weights

Smoke control damper without attachments (weight in kg)

		Width [mm]																				
		200	250	300	350	400	450	500	550	600	650	700	750	800	850	900	950	1000	1050	1100	1150	1200
Height [mm]	200	15	17	17	18	19	20	21	22	23	24	25	26	27	27	28	29	30	31	32	33	34
	400	23	24	25	27	28	29	30	31	33	34	35	36	37	38	40	41	42	43	44	46	47
	600	30	32	33	35	36	37	39	40	42	43	45	46	48	49	51	52	54	55	57	58	60
	800	39	41	42	44	46	48	49	51	53	55	56	58	60	62	63	65	67	69	70	72	74
	1000	46	48	50	52	54	56	58	60	62	64	66	68	70	72	74	76	78	80	82	84	87
	1200	53	55	58	60	62	65	67	69	72	74	76	78	81	83	85	88	90	92	95	97	99
	1400	60	63	65	68	71	73	76	78	81	84	86	89	91	94	96	99	102	104	107	109	112
	1600	67	70	73	76	79	82	85	87	90	93	96	99	102	105	108	110	113	116	119	122	125
	1800	75	78	81	84	87	90	93	97	100	103	106	109	112	115	119	122	125	128	131	134	137
2000	82	85	89	92	95	99	102	106	109	113	116	119	123	126	130	133	137	140	143	147	150	

Weight to be added:

Casing extension for nominal height of ≤ 600 mm

Nominal height	Weight
200	2.9 kg
400	4.4 kg
600	5.9 kg

Additional casing for nominal height of ≥ 800 mm

Nominal height	Weight
800 ... 2000	1.3 kg

Technical data

EKM90 smoke control damper

Extension frame VK (weight in kg)

		Width [mm]																				
		200	250	300	350	400	450	500	550	600	650	700	750	800	850	900	950	1000	1050	1100	1150	1200
Height [mm]	200	3.8	4.0	4.3	4.6	4.8	5.1	5.3	5.6	5.9	6.1	6.4	6.6	6.9	7.2	7.4	7.7	7.9	8.2	8.5	8.7	9.0
	400	4.8	5.1	5.3	5.6	5.9	6.1	6.4	6.6	6.9	7.2	7.4	7.7	7.9	8.2	8.5	8.7	9.0	9.2	9.5	9.8	10.0
	600	5.9	6.1	6.4	6.6	6.9	7.2	7.4	7.7	7.9	8.2	8.5	8.7	9.0	9.2	9.5	9.8	10.0	10.3	10.5	10.8	11.1
	800	6.9	7.2	7.4	7.7	7.9	8.2	8.5	8.7	9.0	9.2	9.5	9.8	10.0	10.3	10.5	10.8	11.1	11.3	11.6	11.8	12.1
	1000	7.9	8.2	8.5	8.7	9.0	9.2	9.5	9.8	10.0	10.3	10.5	10.8	11.1	11.3	11.6	11.8	12.1	14.4	12.6	12.9	13.1
	1200	9.0	9.2	9.5	9.8	10.0	10.3	10.5	10.8	11.1	11.3	11.6	11.8	12.1	12.4	12.6	12.9	13.1	13.4	13.7	13.9	14.2
	1400	10.0	10.3	10.5	10.8	11.1	11.3	11.6	11.8	12.1	12.4	12.6	12.9	13.1	13.4	13.7	13.9	14.2	14.4	14.7	15.0	15.2
	1600	11.1	11.3	11.6	11.8	12.1	12.4	12.6	12.9	13.1	13.4	13.7	13.9	14.2	14.4	14.7	15.0	15.2	15.5	15.7	16.0	16.3
	1800	12.1	12.4	12.6	12.9	13.1	13.4	13.7	13.9	14.2	14.4	14.7	15.0	15.2	15.5	15.7	16.0	16.3	16.5	16.8	17.0	17.3
	2000	13.1	13.4	13.7	13.9	14.2	14.4	14.7	15.0	15.2	15.5	15.7	16.0	16.3	16.5	16.8	17.0	17.3	17.6	17.8	18.1	18.3

Connecting frame A1 (weight in kg)

		Width [mm]																				
		200	250	300	350	400	450	500	550	600	650	700	750	800	850	900	950	1000	1050	1100	1150	1200
Height [mm]	200	5.2	5.3	5.5	5.6	5.8	6.0	6.1	6.3	6.4	6.6	6.8	6.9	7.1	7.2	7.4	7.6	7.7	7.9	8.1	8.2	8.4
	400	5.6	5.8	5.9	6.1	6.2	6.4	6.6	6.7	6.9	7.0	7.2	7.4	7.5	7.7	7.9	8.0	8.2	8.3	8.5	8.7	8.8
	600	6.0	6.2	6.4	6.5	6.7	6.8	7.0	7.2	7.3	7.5	7.7	7.8	8.0	8.1	8.3	8.5	8.6	8.8	8.9	9.1	9.3
	800	6.5	6.6	6.8	7.0	7.1	7.3	7.5	7.6	7.8	7.9	8.1	8.3	8.4	8.6	8.7	8.9	9.1	9.2	9.4	9.5	9.7
	1000	6.9	7.1	7.2	7.4	7.6	7.7	7.9	8.1	8.2	8.4	8.5	8.7	8.9	9.0	9.2	9.3	9.5	9.7	9.8	10.0	10.1
	1200	7.4	7.5	7.7	7.9	8.0	8.2	8.3	8.5	8.7	8.8	9.0	9.1	9.3	9.5	9.6	9.8	9.9	10.1	10.3	10.4	10.6
	1400	7.8	8.0	8.1	8.3	8.5	8.6	8.8	8.9	9.1	9.3	9.4	9.6	9.7	9.9	10.1	10.2	10.4	10.5	10.7	10.9	11.0
	1600	8.3	8.4	8.6	8.7	8.9	9.1	9.2	9.4	9.5	9.7	9.9	10.0	10.2	10.4	10.5	10.7	10.8	11.0	11.2	11.3	11.5
	1800	8.7	8.9	9.0	9.2	9.3	9.5	9.7	9.8	10.0	10.1	10.3	10.5	10.6	10.8	11.0	11.1	11.3	11.4	11.6	11.8	11.9
	2000	9.1	9.3	9.5	9.6	9.8	10.0	10.1	10.3	10.4	10.6	10.8	10.9	11.1	11.2	11.4	11.6	11.7	11.9	12.0	12.2	12.4

Connecting frame A2 (weight in kg)

		Width [mm]																				
		200	250	300	350	400	450	500	550	600	650	700	750	800	850	900	950	1000	1050	1100	1150	1200
Height [mm]	200	4.5	4.8	5.0	5.3	5.6	5.8	6.1	6.3	6.6	6.9	7.1	7.4	7.6	7.9	8.2	8.4	8.7	8.9	9.2	9.5	9.7
	400	5.6	5.8	6.1	6.3	6.6	6.9	7.1	7.4	7.6	7.9	8.2	8.4	8.7	8.9	9.2	9.5	9.7	10.0	10.2	10.5	10.8
	600	6.6	6.9	7.1	7.4	7.6	7.9	8.2	8.4	8.7	8.9	9.2	9.5	9.7	10.0	10.2	10.5	10.8	11.0	11.3	11.5	11.8
	800	7.6	7.9	8.2	8.4	8.7	8.9	9.2	9.5	9.7	10.0	10.2	10.5	10.8	11.0	11.3	11.5	11.8	12.1	12.3	12.6	12.8
	1000	9.1	9.3	9.6	9.8	10.1	10.4	10.6	10.9	11.1	11.4	11.7	11.9	12.2	12.4	12.7	13.0	13.2	13.5	13.7	14.0	14.3
	1200	10.1	10.4	10.6	10.9	11.1	11.4	11.7	11.9	12.2	12.4	12.7	13.0	13.2	13.5	13.7	14.0	14.3	14.5	14.8	15.0	15.3
	1400	11.1	11.4	11.7	11.9	12.2	12.4	12.7	13.0	13.2	13.5	13.7	14.0	14.3	14.5	14.8	15.0	15.3	15.6	15.8	16.1	16.3
	1600	12.2	12.4	12.7	13.0	13.2	13.5	13.7	14.0	14.3	14.5	14.8	15.0	15.3	15.6	15.8	16.1	16.3	16.6	16.9	17.1	17.4
	1800	13.2	13.5	13.7	14.0	14.3	14.5	14.8	15.0	15.3	15.6	15.8	16.1	16.3	16.6	16.9	17.1	17.4	17.6	17.9	18.2	18.4
	2000	14.3	14.5	14.8	15.0	15.3	15.6	15.8	16.1	16.3	16.6	16.9	17.1	17.4	17.6	17.9	18.2	18.4	18.7	18.9	19.2	19.5

Technical data

EKM90 smoke control damper

6.4 Pressure drop, flow velocity and sound power level

Pressure drop

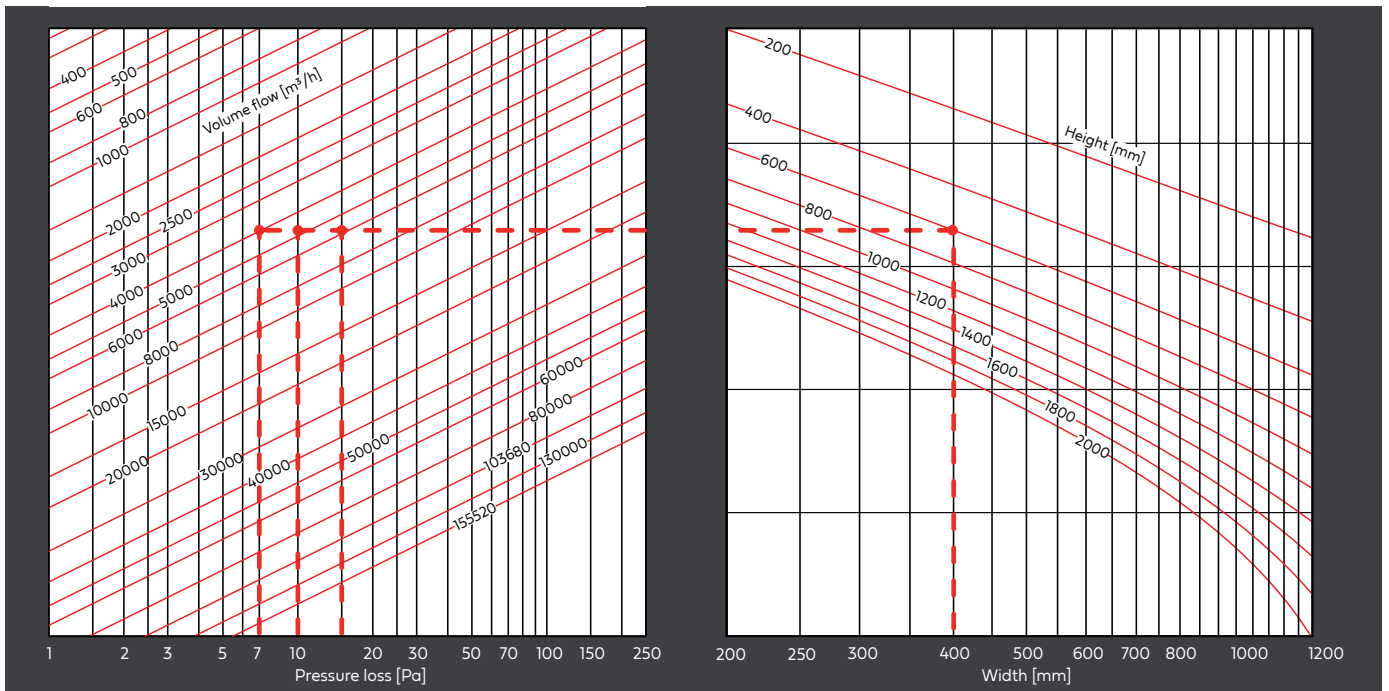

Read out example:

Nominal width *NW* x nominal height *NH*: 400 x 600 mm

Flow rate \dot{V} :	3921	4686	5739	m^3/h
pressure drop Δp_s :	7	10	15	Pa

Maximum flow velocity

		Width [mm]																				
		200	250	300	350	400	450	500	550	600	650	700	750	800	850	900	950	1000	1050	1100	1150	1200
Height [mm]	200	20 m/s																				
	400																					
	600																					
	800																					
	1000																					
	1200																					
	1400																					
	1600																					
	1800																					
	2000	12 m/s																				

Note:

Air flows in the smoke control dampers must not have an unfavourable influence on the rotational forces acting on the blades.

Technical data

EKM90 smoke control damper

Sound power level

Sound power level L_{WA} [dB(A)] at $v = 5$ m/s

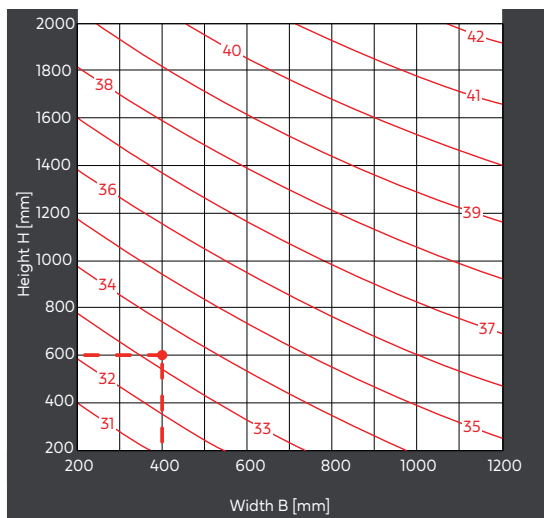

Sound power level L_{WA} [dB(A)] at $v = 10$ m/s

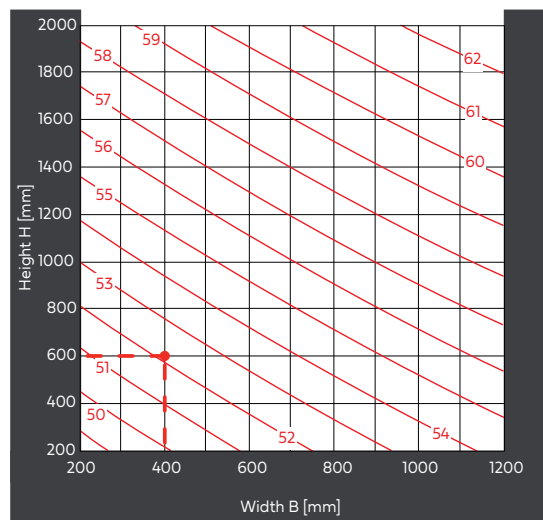

Sound power level L_{WA} [dB(A)] at $v = 15$ m/s

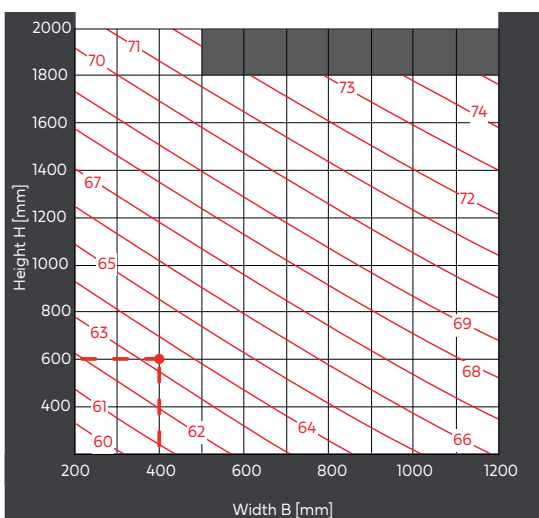

Sound power level L_{WA} [dB(A)] at $v = 20$ m/s

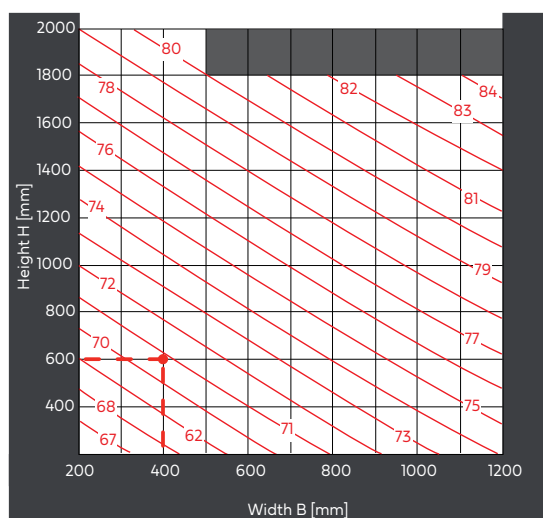

Read out example:

Nominal width NW x nominal height NH : 400 x 600 mm

Inflow velocity V_A :	5	10	15	20	m/s
sound power level L_{WA} :	33	52	63	71	dB(A)

Technical data

EKM90 smoke control damper

6.5 Electric actuators

EKM90 smoke control dampers are equipped with a factory-installed electric actuator. The actuators differ in their functions and electrical connections.

Actuator and actuator size	Electrical connection					Power			Runtime for 90°	Manual adjustment
	Voltage	Tolerance AC	Tolerance DC	Connected load	Wires	Run	Stop	I _{max} @ 5 ms		
M1 1 (15 Nm) 2 (25 Nm) 3 (40 Nm)	24V AC/DC	19.2 ... 28.8 V	21.6 ... 28.8 V	6 VA	9 x 0.75 mm ²	3 W	0.1 W	8.2 A	< 30 s	Hand crank / ratchet wrench
				5 VA		2.5 W	0.1 W		< 60 s	
				18 VA		12 W	0.5 W		< 60 s	
M2 1 (15 Nm) 2 (25 Nm) 3 (40 Nm)	230 V AC	198 ... 264 V	-	7 VA	9 x 0.75 mm ²	4 W	0.4 W	4 A	< 30 s	Hand crank / ratchet wrench
				6 VA		3.5 W	0.4 W		< 60 s	
				15 VA		8 W	0.5 W		7.9 A	
M3 1 (15 Nm) 2 (25 Nm)	24V AC/DC	19.2 ... 28.8 V	21.6 ... 28.8 V	6.5 VA	10 x 0.75 mm ²	3 W	0.3 W	8.2 A	< 30 s	Hand crank / ratchet wrench
				5.5 VA					< 60 s	

Height-dependent assignment of actuators:

Height [mm]	Width [mm]	
	200	400 ... 600
200	200 ... 1200	
400 ... 600	M1 actuator size 1 / M2 actuator size 1 / M3 actuator size 1	
800 ... 2000	M1 actuator size 2 / M2 actuator size 2 / M3 actuator size 2	
	M1 actuator size 3 / M2 actuator size 3	

Electrical connection		Notes																																		
M1 – reversible actuator	M2 – reversible actuators																																			
<p>Limit switch CLOSED Limit switch OPEN</p>	<p>Limit switch CLOSED Limit switch OPEN</p>	<p>Contact illustration: Smoke control damper closed</p> <p>In the event of a power failure or interruption, the current actuator position is retained.</p> <p>For actuators with a factory-installed AMP connector, the connector can be removed if required.</p> <p>Limit switch positions</p> <table border="1"> <thead> <tr> <th rowspan="2">Damper</th> <th colspan="3">Limit switch CLOSED</th> <th colspan="3">Limit switch OPEN</th> </tr> <tr> <th>1</th> <th>2</th> <th>3</th> <th>4</th> <th>5</th> <th>6</th> </tr> </thead> <tbody> <tr> <td>CLOSED</td> <td>←→</td> <td>←→</td> <td>←→</td> <td>←→</td> <td>←→</td> <td>←→</td> </tr> <tr> <td>Int. position</td> <td>←→</td> <td>←→</td> <td>←→</td> <td>←→</td> <td>←→</td> <td>←→</td> </tr> <tr> <td>OPEN</td> <td>←→</td> <td>←→</td> <td>←→</td> <td>←→</td> <td>←→</td> <td>←→</td> </tr> </tbody> </table> <p>Intermediate cables:</p> <p> Power supply Limit switch</p>	Damper	Limit switch CLOSED			Limit switch OPEN			1	2	3	4	5	6	CLOSED	←→	←→	←→	←→	←→	←→	Int. position	←→	←→	←→	←→	←→	←→	OPEN	←→	←→	←→	←→	←→	←→
Damper	Limit switch CLOSED			Limit switch OPEN																																
	1		2	3	4	5	6																													
CLOSED	←→	←→	←→	←→	←→	←→																														
Int. position	←→	←→	←→	←→	←→	←→																														
OPEN	←→	←→	←→	←→	←→	←→																														
M3 – Continuously variable actuator																																				
<p>Limit switch CLOSED Limit switch OPEN</p>																																				

Technical data

EKM90 smoke control damper

Recommended drilling positions for cable entry

The areas for the drilling positions apply to the shown nominal widths of the EKM90 and must be transferred to the respective size of damper. Before drilling, ensure that there are no obstacles such as cables in the way. The necessary holes must be drilled on site as required.

Area for drilling positions in fixed back wall

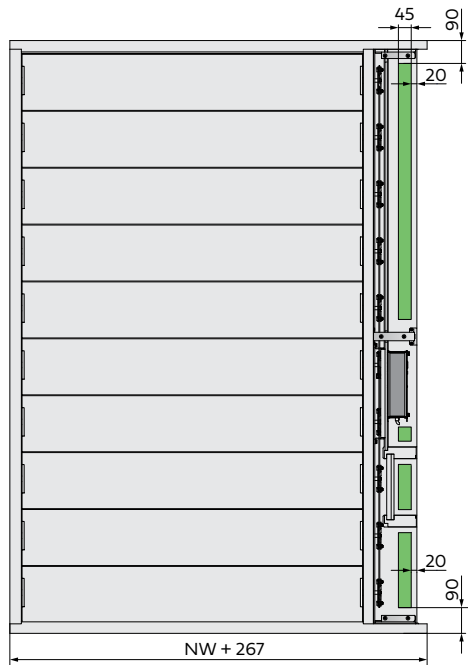

Area for drilling positions on the side

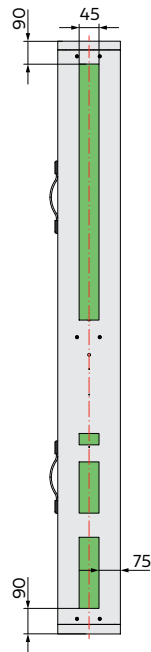

Area for drilling positions from the front

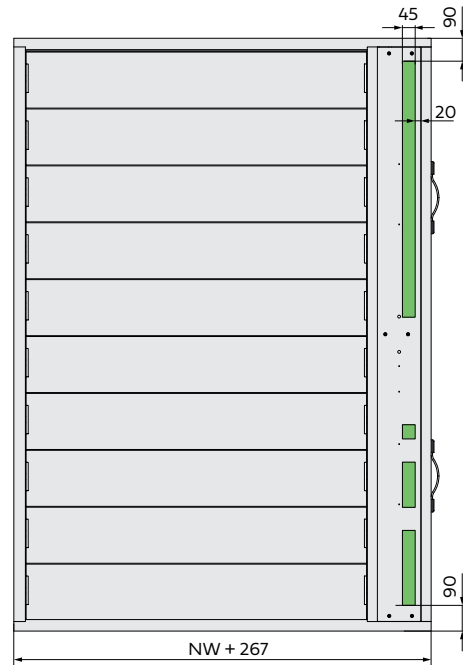

Area for top/bottom drilling positions

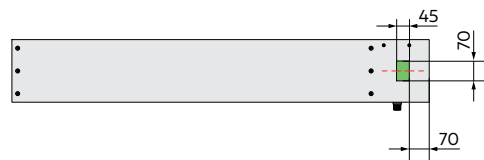

Casing extension for NH of ≤ 600 mm

For cable entry and installation, the insulating plate can be completely removed or drilled or notched as required!

Area for drilling positions in fixed back wall

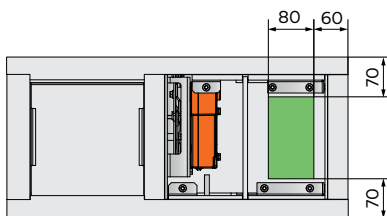

Area for top/bottom drilling positions

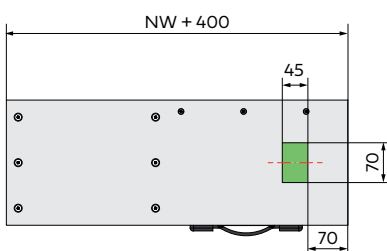

Additional casing for NH of ≥ 800 mm

For cable entry and installation, the upper and lower intermediate plates can be drilled or recessed at the front and back as required!

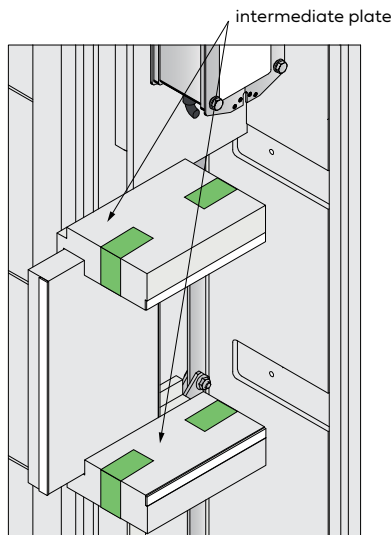

Note: In a factory-installed additional casing, the intermediate plates are glued and screwed to the back wall of the actuator casing!

7 Specification text

7.1 EKM90 smoke control damper

Maintenance-free multi-blade smoke control dampers EKM90 conforming to EN 12101-8 with Declaration of Performance and CE marking, up to 120 minutes fire resistance period and fire classification EI 90/120 ($v_{edw} - h_{odw} - i \leftrightarrow o$) S1000 C_{mod} HOT400/30 MA multi, for mechanical systems for smoke extraction, ventilation and air supply to multiple or individual fire zones, fire compartments or rooms, for mechanical smoke extraction systems as well as pressurised ventilation systems and for secondary air flow. Can be used flexibly with horizontal or vertical blades (shaft position). Maintenance-free: The actuator unit is fully enclosed, which means that no cleaning or regular lubrication and adjustment need to be done to maintain function. Casing and blades made of abrasion-resistant calcium silicate, suitable for high temperatures. Stainless-steel drive shafts and mechanism and electric motor for 24V AC/DC or 230V AC. Also suitable for modulation mode (C_{mod} , weight-loaded tested) and for reopening (MA). Additional casing / casing extension for connecting client's control units. Special seals for opening and closing the smoke control dampers during exposure to fire. For installation in rigid walls and ceilings with mortar or mineral wool, in flexible walls and shaft walls as well as in/on or between smoke extraction ducts. Casing length only 220 mm.

..... pcs.

Width:	mm
Height:	mm
Volume flow:	m ³ /h
Pressure drop:	Pa
Sound power level:	dB(A)	

Fire classification:

EI 90/120 ($v_{edw} - h_{odw} - i \leftrightarrow o$) S1000 C_{mod} HOT400/30 MA multi
Environmental product declaration according to ISO 14025 and EN 15804

Manufacturer: WILDEBOER

Type: EKM90

- Optionally with additional casing
- Optionally with casing extension

deliver:
install:

Delete text not printed in bold as required!

7.2 Accessories

7.2.1 VK extension frame

VK extension frame made of calcium silicate for installing smoke extraction ducts made of construction boards (e.g. Promat Promatect LS) with fire resistance period.

..... pcs.

Nominal width:	mm
Nominal height:	mm
Manufacturer:	WILDEBOER	
		deliver:.....
		install:.....

7.2.2 A1 connecting frame

A1 connecting frame made of galvanised sheet steel, connection seal and screws for installing the protective grille.

..... pcs.

Nominal width:	mm
Nominal height:	mm
Manufacturer:	WILDEBOER	
		deliver:.....
		install:.....

7.2.3 A2 connecting frame

A2 connecting frame made of calcium silicate with screws and adhesive for installing smoke extraction ducts made of sheet steel or for installing the protective grille.

..... pcs.

Nominal width:	mm
Nominal height:	mm
Manufacturer:	WILDEBOER	
		deliver:.....
		install:.....

7.2.4 Protective grille

Protective grille for smoke control dampers without connecting ducts to protect the flow-through openings. Pressed with 20 mm mesh size from 1.5 mm galvanized sheet steel.

..... pcs.

Nominal width:	mm
Nominal height:	mm
Manufacturer:	WILDEBOER	
		deliver:.....
		install:.....

Specification text

EKM90 smoke control damper

7.2.5 Connecting seal

Connecting seal for dry installation in rigid ceilings, quantity depends on nominal height.

NH < 1600 mm = 1 pack of connecting seals

NH ≥ 1600 mm = 2 packs of connecting seals

..... pcs.

Manufacturer: WILDEBOER

deliver:.....

install:.....

7.2.6 Wall anchors

Wall anchors for wet installation in rigid walls and ceilings, quantity depends on nominal height.

NH < 1600 mm: 1 pack of wall anchors required

NH of ≥ 1600 mm: 2 packs of wall anchors required

..... pcs.

Manufacturer: WILDEBOER

deliver:.....

install:.....

Wildeboer makes it simple

EKM90 smoke control damper

8 Wildeboer makes it simple

8.1 Wildeboer Configurator

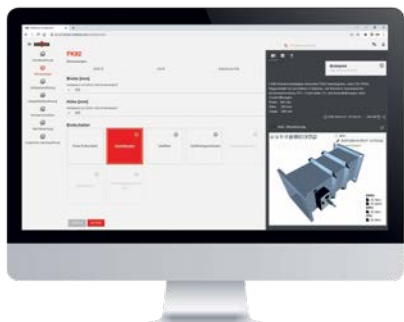

- Quick, intuitive configuration of Wildeboer products
- Easy calculation of the operating point data for the configured product
- 3D display of the product and download in various formats
- Download of data sheets, specification texts and version keys
- Login area with price display option



8.2 WiDim dimensioning software

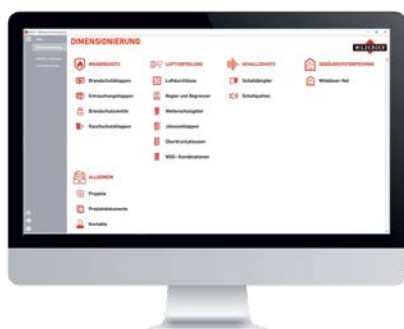

- Functional, modern and intuitive dimensioning of Wildeboer products
- Conveniently collect operating point data, 3D product views, suitable accessories and current revision documents in a single project
- Project can be output in various formats
- A GAEB interface and another based on VDI 3805 facilitate a seamless planning process



8.3 Documents online



- Paperless and environmentally friendly online access to Wildeboer documents
- All documents in one central location and always up to date
- Supporting interactive formats and content



Always there for you

Locations & Contacts

WILDEBOER

Factory - Administration
+49 4951 950-0
info@wildeboer.de
www.wildeboer.de

Utrecht

WILDEBOER

Utrecht office
+31 30 767 0150
info@utrecht.wildeboer.eu
www.wildeboer.de/nl

Leipzig

WILDEBOER

Leipzig office
+49 34444 310-0
info@leipzig.wildeboer.de
www.wildeboer.de

Ulm

WILDEBOER

Ulm office
+49 7392 9692-0
info@ulm.wildeboer.de
www.wildeboer.de

Other locations marked on the map: Weener, Hamburg, Hanover, Berlin, Cologne, Frankfurt, Stuttgart, Munich.



Find out more at
www.wildeboer.de/downloads

