

DT swirl diffuser

For air distribution with the highest demands

Smooth gloss front panel finishes

Minimum installation heights using special plenum boxes

DT swirl diffuser

Description, type overview

DT swirl diffuser with the tried-and-tested and high-performance progressively twisted blade profile. This makes high volume flow rates possible at low sound power levels, while the radially and axially symmetrical design of the front panel ensures perfect air flow.

DT swirl diffuser for supply air and exhaust air with constant and variable volume flow rates. The air is distributed symmetrically by a square or round front panel with a radial, optically sophisticated design, and the tried-and-tested and high-performance progressively twisted blade profile.

DT swirl diffusers ensure high induction with the room air directly at the outlet. This quickly reduces the velocity of the flowing supply air and the temperature differentials. This also applies when heating or cooling a room with a temperature difference of -12 K between the room air and supply air. If the minimum volume flow rates are maintained in the area of application, there is never a risk of airflow coming off the ceiling when cooling a room. Air is deflected into the occupied zone by room walls and counterflows. Optimum air distribution is possible in rooms with heights of approximately 2.5 to 4 m, and is best achieved with plenum boxes installed flush in ceilings.

DT swirl diffusers are made of galvanized sheet steel. The front panels retain a resistant sintered polyester surface at high temperature, which is extremely colour-fast and anti-static. With powdered coating in colour RAL 9010 (white) smooth glossy with 80 to 90% gloss level or in another RAL colour.

The **plenum boxes** made of galvanized sheet steel are optimised for swirl diffusers and low heights and are also available with powder coating. One or two side-entry connecting pieces or a top-entry connection are possible as standard features, as well as dampers and special air deflector plates for optimum air distribution with low flow noises, in particular for supply air. The volume flow can be adjusted without dismantling the swirl diffuser. With holes for suspensions and with concealed central attachment.

For closed ceilings systems, grid ceilings and for freely suspended installation.

Type overview

Swirl diffuser and plenum box with	DTQ0			DTR0	
	side	two side	upper	side	upper
	Connecting piece			Connecting piece	
• without damper, without air deflector plate	K1	K2	K3	R1	R3
• with damper	K1-D	K2-D	K3-D	R1-D	R3-D
• with air deflector plate	K1-L	K2-L	K3-L	R1-L	R3-L
• with damper, with air deflector plate	K1-DL	K2-DL	K3-DL	R1-DL	R3-DL

Central fastening

with concealed screws M8x25:

Colour of swirl diffuser

RAL 9010 | Special colour RAL.....

Colour of corresponding cap

White RAL 9010 | Black RAL 9017 | Special colour RAL.....



DT swirl diffuser

Data sheet: Front plates

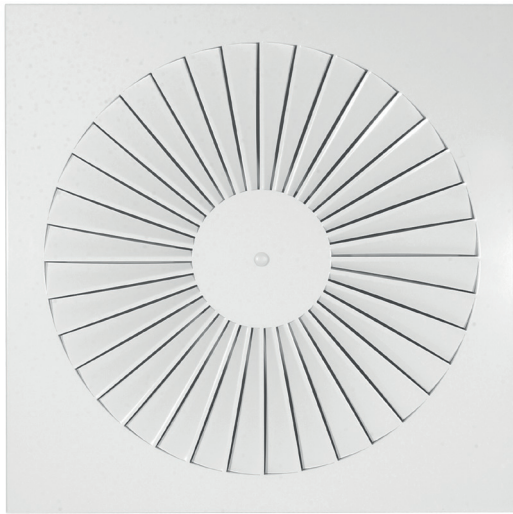

Square front panel DTQ0 600

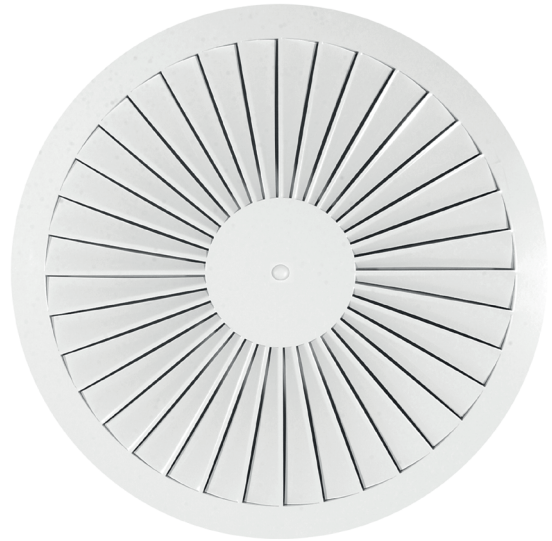

Circular front panel DTR0 600

Nominal sizes

Nominal size	Hole pattern Plenum box size	DTQ0 square		DTR0 circular		A _{free} [m ²]	Application with supply air from: ⇒ see page 16
		∅ A	∅ F	∅ A	∅ F		
325	325	323	260	325	285	0.0175	25 m ³ /h
400	400	398	337	400	360	0.0287	60 m ³ /h
500	500	498	437	500	460	0.0509	100 m ³ /h
600	600	595	537	600	560	0.0814	200 m ³ /h
625	600	623	537	-	-	0.0814	200 m ³ /h
600	325	595	260	-	-	0.0175	25 m ³ /h
600	400	595	337	-	-	0.0287	60 m ³ /h
600	500	595	437	-	-	0.0509	100 m ³ /h
625	325	623	260	-	-	0.0175	25 m ³ /h
625	400	623	337	-	-	0.0287	60 m ³ /h
625	500	623	437	-	-	0.0509	100 m ³ /h

Special designs

- Coating of front plates with polyester in other colours. Colours are available from the RAL CLASSIC colour collection as standard. Customised colours – besides those available at the factory – can always be ordered!
- Coating of plenum boxes with polyester, black inside and outside, or outside in colours²⁾ as before.

²⁾for colours ⇒ see page 18

- The nominal sizes match the front panels.
- The hole patterns correspond to the plenum box sizes. They determine the free cross-sections A_{free} of swirl diffusers.
- The front panels for supply air and exhaust air are identical.

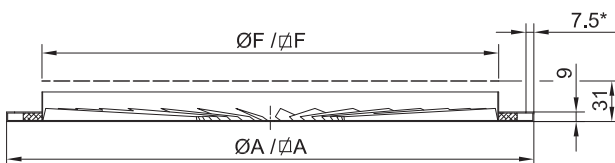

*) surrounding edging on DTQ0 only

A: Front panel dimension
F: light ceiling cut-out dimension

All dimensions in mm

DT swirl diffuser

Plenum boxes for closed ceilings systems, grid ceilings and for freely suspended installation

K1 - with side-entry connecting piece

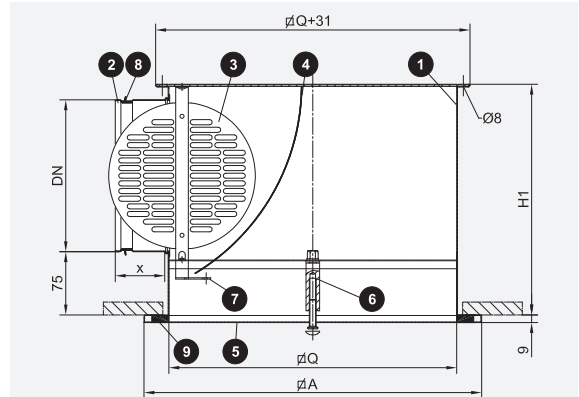

K2 - with two side-entry connecting pieces for large volume flow rates at low plenum box height H1

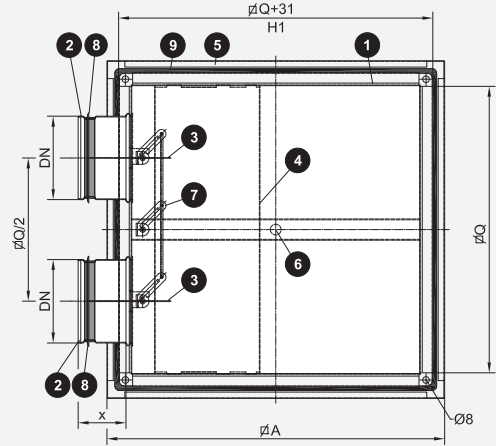

K3 - with top connecting piece

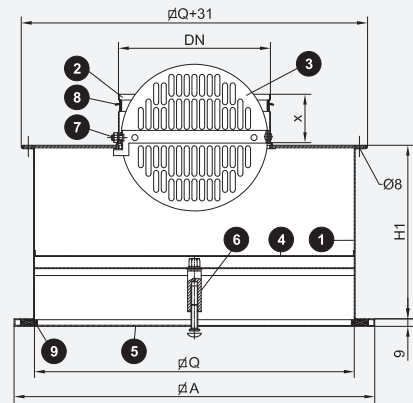

Front panel dimension $\varnothing A \Rightarrow$ see page 3
Parts list \Rightarrow see page 5

Plenum box heights H1 [mm]

Standard connecting pieces and heights of plenum boxes K1 are in bold.

Plenum box size Hole pattern	$\varnothing Q$	Plenum box K1 with connecting piece DN											K2 with DN						K3 with DN			
		100	125	150	160	180	200	224	250	280	300	315	100	125	150	160	180	200	224	160	200	250
325	260	190	215	240	250	270	290	-	-	-	-	-	190	-	-	-	-	-	-	190	-	-
400	337	-	215	240	250	270	290	314	-	-	-	-	190	215	-	-	-	-	-	-	190	-
500	437	-	-	240	250	270	290	314	340	370	-	-	-	215	240	250	270	-	-	-	190	-
600 ¹⁾	537	-	-	240	250	270	290	314	340	370	390	405	-	215	240	250	270	290	314	-	-	200
Connecting piece x		40	40	40	40	40	40	60	60	60	60	60	40	40	40	40	40	40	60	40	40	60

¹⁾ Plenum box size 600 is for swirl diffusers of nominal sizes 600 and 625 (hole pattern 600).

DT swirl diffuser

Plenum boxes for closed ceilings systems, grid ceilings and for freely suspended installation

R1 - with side-entry connecting piece

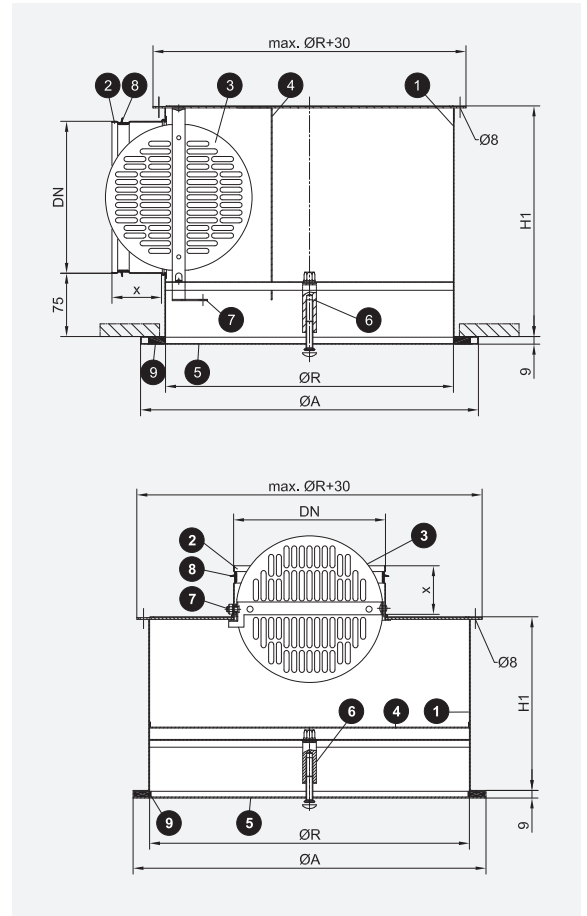

R3 - with top connecting piece



Front panel dimension Ø A ⇒ see page 3

Plenum box heights H1 [mm]

Standard connecting pieces and heights of plenum boxes R1 are in bold.

Plenum box size Hole pattern	Ø R	Plenum box R1 with connecting piece DN											R3 with DN		
		100	125	150	160	180	200	224	250	280	300	315	160	200	250
325	285	190	215	240	250	270	290	-	-	-	-	-	190	-	-
400	360	-	215	240	250	270	290	314	-	-	-	-	-	190	-
500	460	-	-	240	250	270	290	314	340	370	-	-	-	190	-
600	560	-	-	240	250	270	290	314	340	370	390	405	-	-	200
Connecting piece x		40	40	40	40	40	40	60	60	60	60	60	40	40	60

Parts list

- | | | |
|--------------------|--------------------------------|-------------------------------|
| 1 Plenum box | 4 Air deflector plate (option) | 7 Adjustment device of damper |
| 2 Connecting piece | 5 Swirl diffuser | 8 Lip seal (optional) |
| 3 Damper (option) | 6 Central fastening | 9 Seal |

DT swirl diffuser

Dimensioning of room airflow

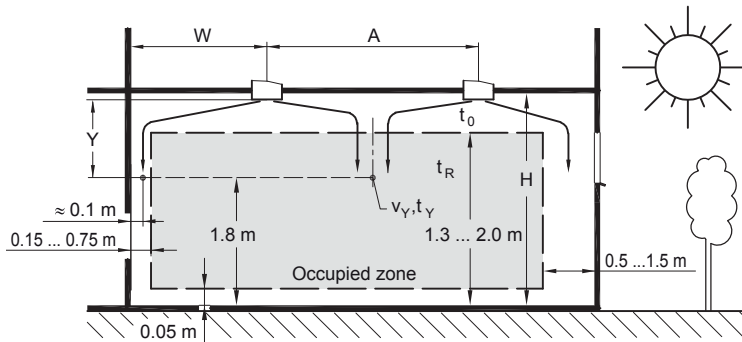

Occupied zone according to EN 13779

The occupied zone is defined in EN 13779 as a spatial element. The comfort criteria it lays out must be met.

In the usual area of application, the height is 1.30 m to 2.00 m. The permissible flow velocities v_y should be set as standard at a height of 1.80 m. Higher velocities are permissible outside the occupied zone, at distances from 0.15 m to 0.75 m from interior and exterior walls and from 0.5 m to 1.5 m from exterior walls which have windows or doors.

Dimensioning of DT swirl diffusers

The flow velocity v_y is determined in accordance with the hole pattern by the free swirl diffuser cross-section A_{free} , by the volume flow V , by the room height H , by the orthogonal distances A and B of the swirl diffusers with respect to each other and their wall distance W . In addition to the absolute distances A and B , the ratio of A to B is important. Swirl diffusers in extremely rectangular arrangements with $A \gg B$ or $B \gg A$, which can also be single-row arrangements, produce significantly different flow velocities v_y compared to square and slightly rectangular arrangements. By using suitable arrangements therefore, the flow velocities in the room can be optimised; which may be particularly necessary with a high air change rate.

The following applies to the occupied zone:

DT swirl diffusers achieve

- lower flow velocities v_y if
 - the distances A and B are considerably greater than 2.65 m,
 - the distances A and B are very different and a distance much shorter than 2.65 m, or
- higher flow velocities v_y if
 - the distances A and B are equal, but less than 2.65 m,
 - a distance, A or B , is equal to 2.65 m.

The flow velocities v_y of DT swirl diffusers in the area of the wall reduce as the distances increase. This applies for the distances A or B of the swirl diffusers parallel to the wall and also for their distance W from the wall.

The nomograms show these relationships and the effect of adjacent walls.

The room airflow can be optimised using various arrangements of DT swirl diffusers and a corresponding choice of size. In this way, it is possible to use fewer swirl diffusers. However, effective room airflow and large enough flow velocities for effective airflow in the room should also always be ensured.

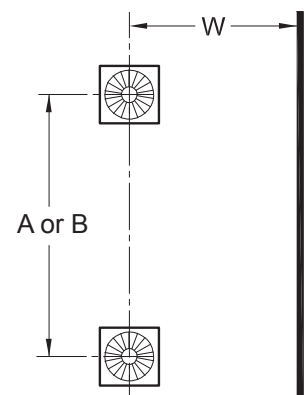
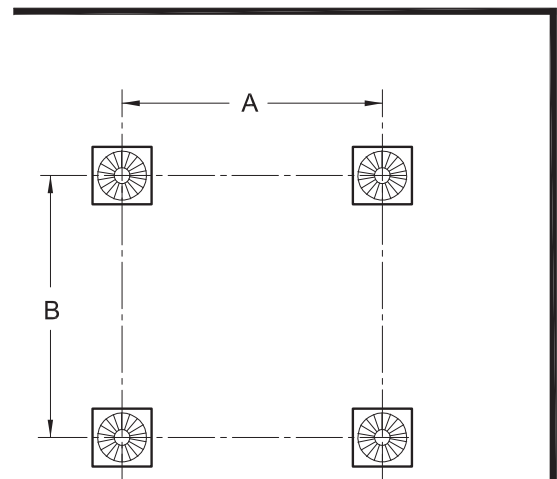

DT swirl diffuser

Dimensioning example

Rectangular arrangement

Specified:

Room dimension 1	15.0 m
Room dimension 2	12.0 m
Room height	H = 3.3 m
Ceiling spacing	Y = 1.5 m
Air change	11.1 h ⁻¹
Room volume	594 m ³
Total volume flow	V _{tot} = 6600 m ³ /h
Room temperature	t _R = 22 °C
Supply air temperature	t ₀ = 16 °C

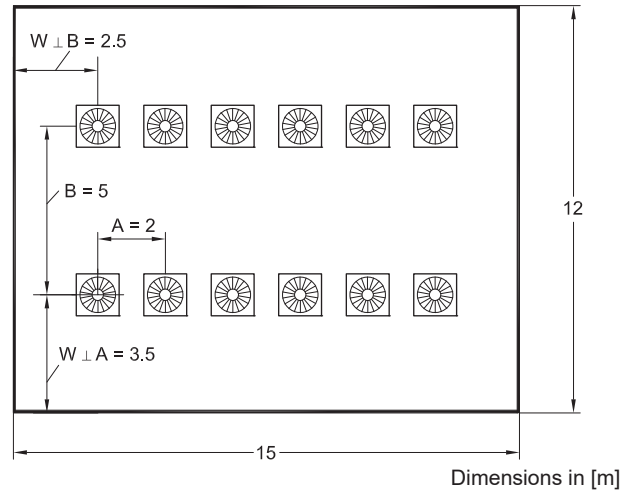

Plenum box with standard connection piece

DTQ0 - 500 - 500 - K1 - 200 - DL¹⁾	12 pc
Volume flow per diffuser	V = 550 m ³ /h
Inflow cross-section of connecting pieces	A _A = 0,031 m ²
Flow velocity in A _A	v _A = 4.9 m/s
Δp _t , damper OPEN	Δp _t = 27 Pa
L _{WA} , damper OPEN	L _{WA} = 38 dB(A)
⇒ see nomogram page 10	
Δp _t , damper CLOSED	27 Pa · 3.2 ²⁾ = 86 Pa
L _{WA} , damper CLOSED	38 dB(A) + 9.8 ²⁾ = 48 dB(A)

Octave sound power level L_{W-OkT}, damper OPEN

f [Hz]	63	125	250	500	1000	2000	4000	8000
L _{WA} [dB(A)]	38	38	38	38	38	38	38	38
ΔL _{4.9 [m/s]} [dB]	+ 5	+ 2	+ 1	- 2	- 4	- 13	- 21	- 24
L _{W-OkT} [dB]	43	40	39	36	34	25	< 20	< 20

⇒ see nomogram page 10

Plenum box with other connecting piece size

DTQ0 - 500 - 500 - K1 - 250 - DL¹⁾	12 pc
Volume flow per diffuser	V = 550 m ³ /h
Inflow cross-section of connecting pieces	A _A = 0,049 m ²
Flow velocity in A _A	v _A = 3.1 m/s
Δp _t , damper OPEN	27 Pa · 0.6 ³⁾ = 16 Pa
L _{WA} , damper OPEN	38 dB(A) - 4.8 ³⁾ = 33 dB(A)
Δp _t , damper CLOSED	27 Pa · 0.6 ³⁾ · 2.5 ²⁾ = 41 Pa
L _{WA} , damper CLOSED	38 dB(A) - 4.8 ³⁾ + 6.1 ²⁾ = 39 dB(A)

Octave sound power level L_{W-OkT}, damper OPEN

f [Hz]	63	125	250	500	1000	2000	4000	8000
L _{WA} [dB(A)]	33	33	33	33	33	33	33	33
ΔL _{3.1 [m/s]} [dB]	+ 6	+ 3	+ 1	- 2	- 4	- 16	- 26	- 27
L _{W-OkT} [dB]	39	36	34	31	29	< 20	< 20	< 20

⇒ see nomogram page 10

¹⁾ Order information ⇒ see pages 2 and 18

²⁾ Correction values ⇒ see page 15

³⁾ Correction values ⇒ see page 14

Room airflow

Distance A	A = 2.00 m
Distance B	B = 5.00 m
Distance W, at right angles to A	W = 3.50 m
Distance W, at right angles to B	W = 2.50 m
Flow velocity in occupied zone	v _y = 0.15 m/s
⇒ see nomogram page 8	
Flow velocity at the wall, at right angles to A	v _y = 0.23 m/s
⇒ see nomogram page 9	
Flow velocity at the wall, at right angles to B	v _y = 0.19 m/s
⇒ see nomogram page 9	
Temperature ratio	Δt/Δt ₀ = 0,043
Induction	i = 22
⇒ see nomogram page 13	

Nomenclature ⇒ see page 13

DT swirl diffuser

Room airflow (jets towards each other)

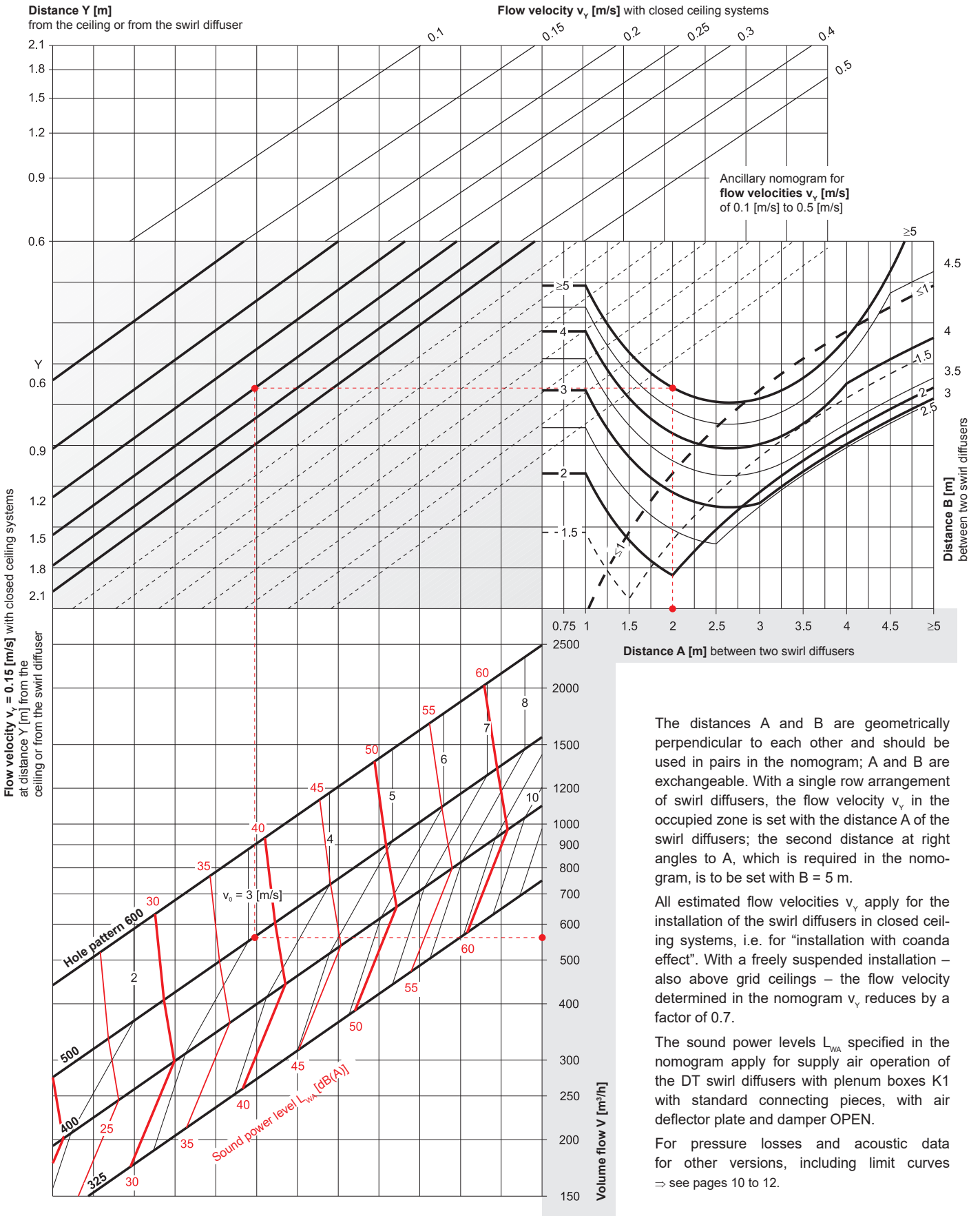

The distances A and B are geometrically perpendicular to each other and should be used in pairs in the nomogram; A and B are exchangeable. With a single row arrangement of swirl diffusers, the flow velocity v_y in the occupied zone is set with the distance A of the swirl diffusers; the second distance A at right angles to A, which is required in the nomogram, is to be set with B = 5 m.

All estimated flow velocities v_y apply for the installation of the swirl diffusers in closed ceiling systems, i.e. for "installation with coanda effect". With a freely suspended installation – also above grid ceilings – the flow velocity determined in the nomogram v_y reduces by a factor of 0.7.

The sound power levels L_{wa} specified in the nomogram apply for supply air operation of the DT swirl diffusers with plenum boxes K1 with standard connecting pieces, with air deflector plate and damper OPEN.

For pressure losses and acoustic data for other versions, including limit curves ⇒ see pages 10 to 12.

In addition, note the minimum volume flow rates! ⇒ see page 16

DT swirl diffuser

Room airflow (jets towards a wall)

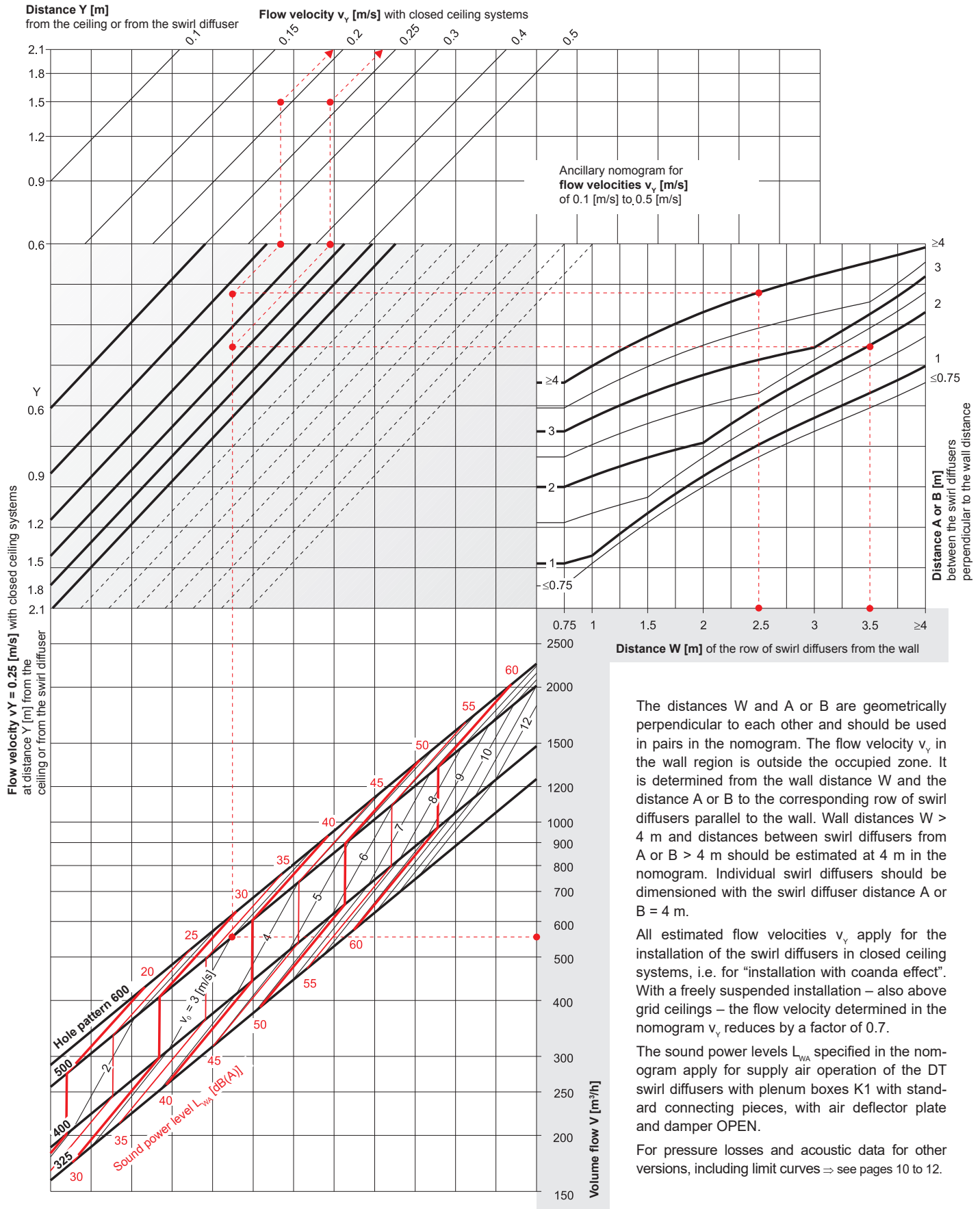

In addition, note the minimum volume flow rates! ⇒ see page 16

The distances W and A or B are geometrically perpendicular to each other and should be used in pairs in the nomogram. The flow velocity v_y in the wall region is outside the occupied zone. It is determined from the wall distance W and the distance A or B to the corresponding row of swirl diffusers parallel to the wall. Wall distances $W > 4$ m and distances between swirl diffusers from A or B > 4 m should be estimated at 4 m in the nomogram. Individual swirl diffusers should be dimensioned with the swirl diffuser distance A or B = 4 m.

All estimated flow velocities v_y apply for the installation of the swirl diffusers in closed ceiling systems, i.e. for "installation with coanda effect". With a freely suspended installation – also above grid ceilings – the flow velocity determined in the nomogram v_y reduces by a factor of 0.7.

The sound power levels L_{wa} specified in the nomogram apply for supply air operation of the DT swirl diffusers with plenum boxes K1 with standard connecting pieces, with air deflector plate and damper OPEN.

For pressure losses and acoustic data for other versions, including limit curves ⇒ see pages 10 to 12.

DT swirl diffuser

Pressure drop, sound power level, NR (noise rating), relative sound power level

Supply air: DTQ0 with plenum box K1-DL

with air deflector plate and damper OPEN

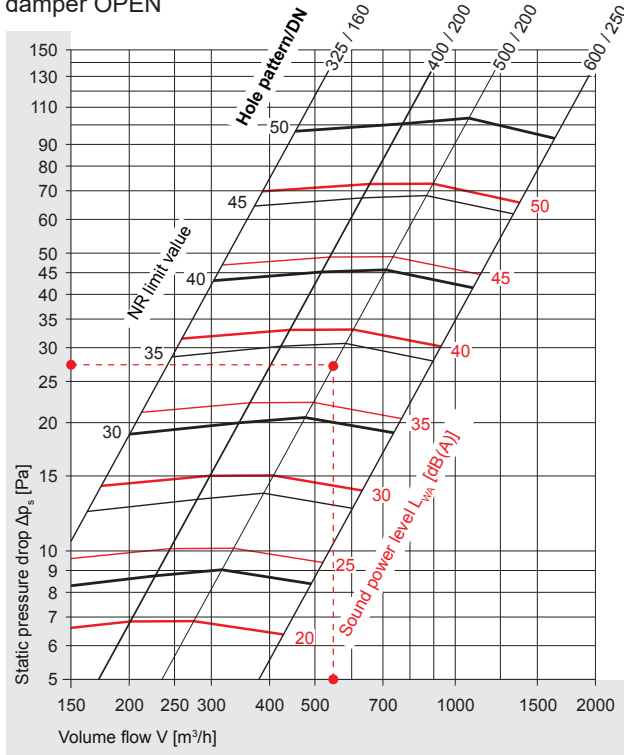

Exhaust air: DTQ0 with plenum box K1-D

without air deflector plate and damper OPEN

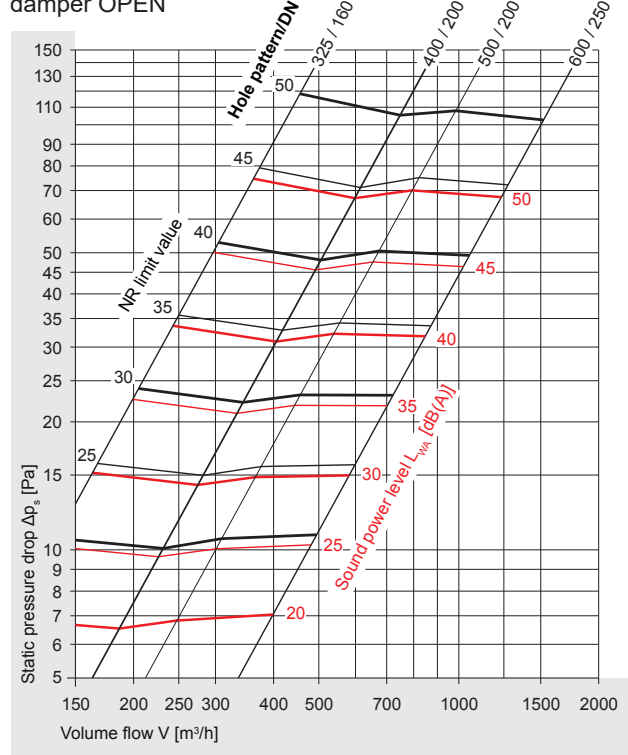

In addition, note the minimum volume flow rates!
 ⇒ see page 16

Corrections for other connecting piece sizes and for damper CLOSED ⇒ see pages 14 and 15.

Supply air: DTQ0 with plenum box K1-DL

with air deflector plate and damper OPEN

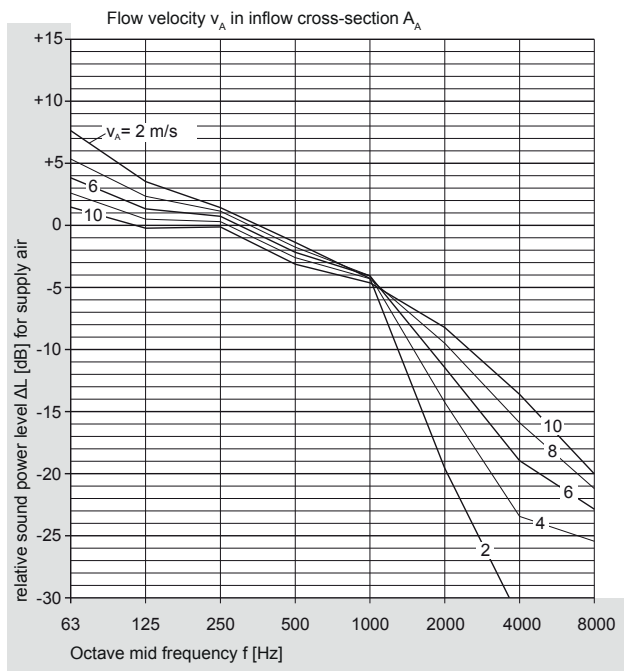

Exhaust air: DTQ0 with plenum box K1-D

without air deflector plate and damper OPEN

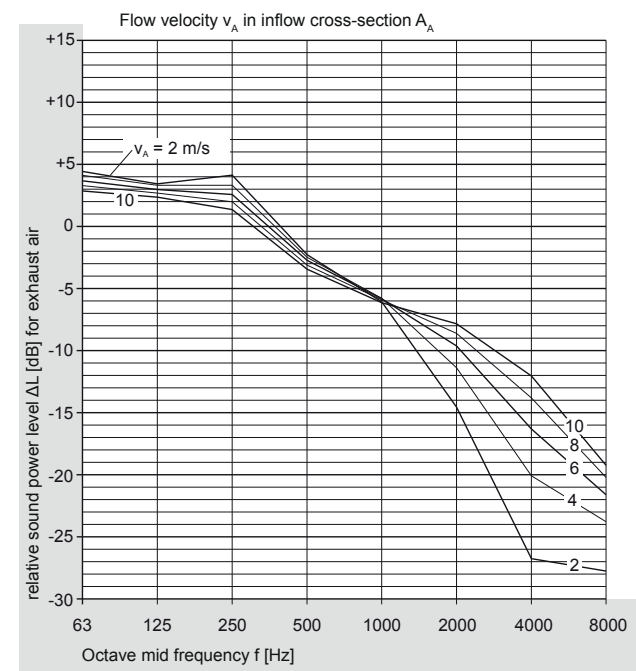

DT swirl diffuser

Pressure drop, sound power level, NR (noise rating)

Supply air: DTQ0 with plenum box K2-DL

with air deflector plate and damper OPEN

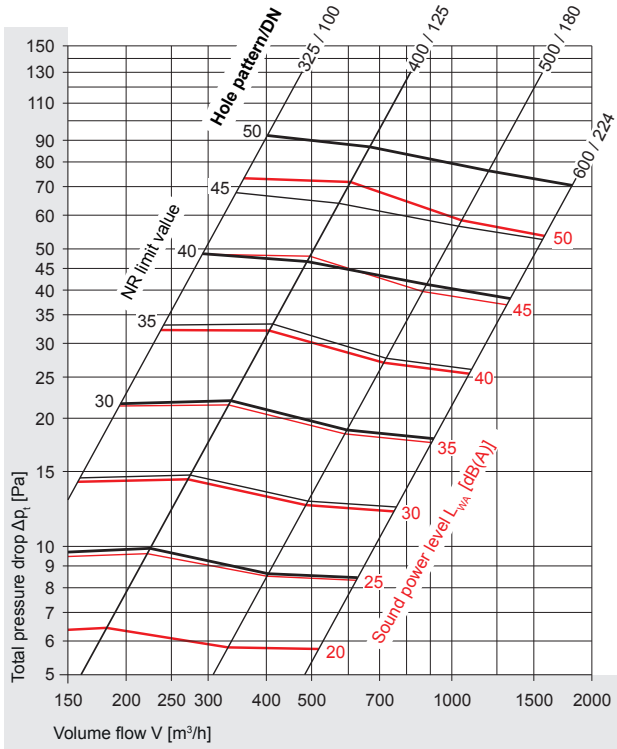

Exhaust air: DTQ0 with plenum box K2-D

without air deflector plate and damper OPEN

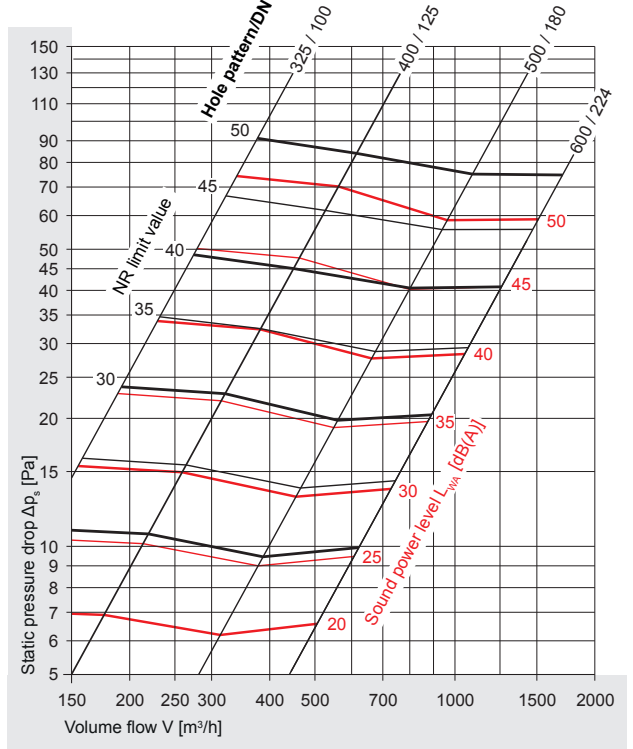

Supply air: DTQ0 with plenum box K3-DL

with air deflector plate and damper OPEN

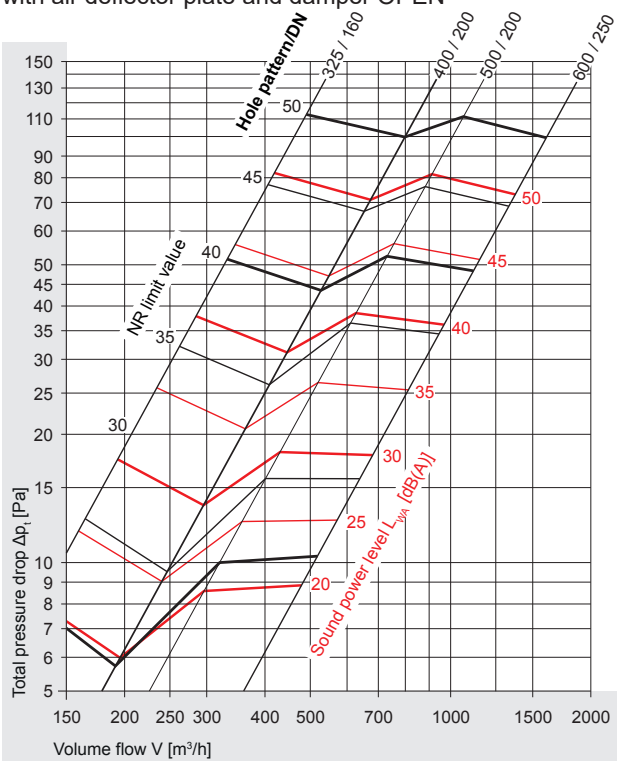

Exhaust air: DTQ0 with plenum box K3-D

without air deflector plate and damper OPEN

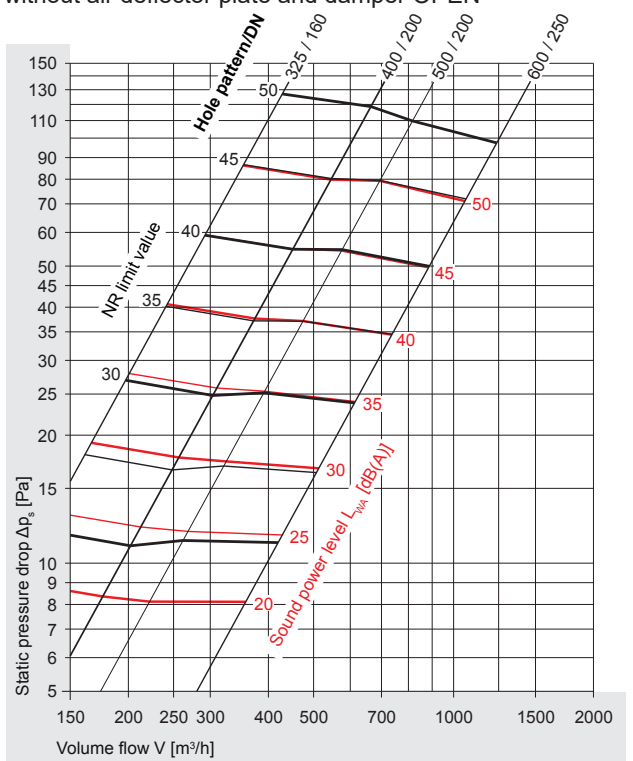

In addition, note the minimum volume flow rates!
 ⇒ see page 16

Corrections for other connecting piece sizes and for damper CLOSED ⇒ see pages 14, 15 and 16.
 Relative sound power level ΔL for plenum boxes K2 and K3 ⇒ see WILDEBOER - dimensioning software.

DT swirl diffuser

Pressure drop, sound power level, NR (noise rating)

Supply air: DTR0 with plenum box R1-DL

with air deflector plate and damper OPEN

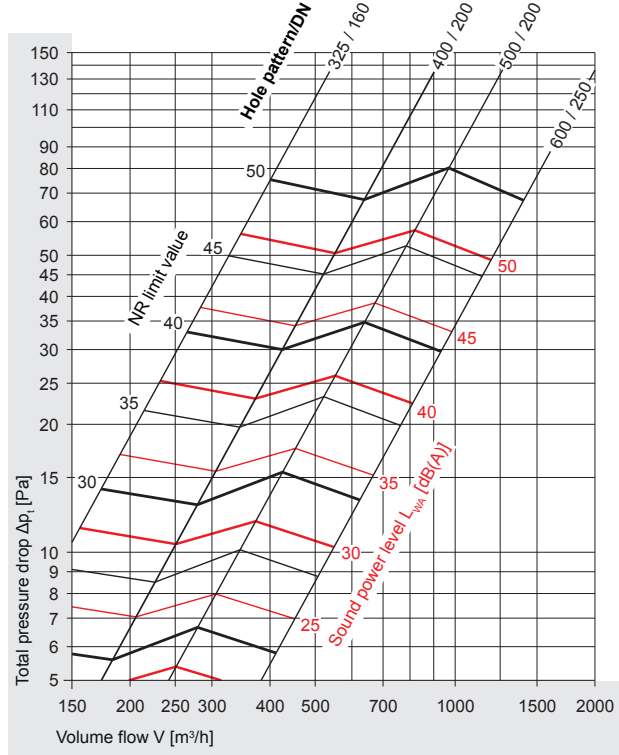

Exhaust air: DTR0 with plenum box R1-D

without air deflector plate and damper OPEN

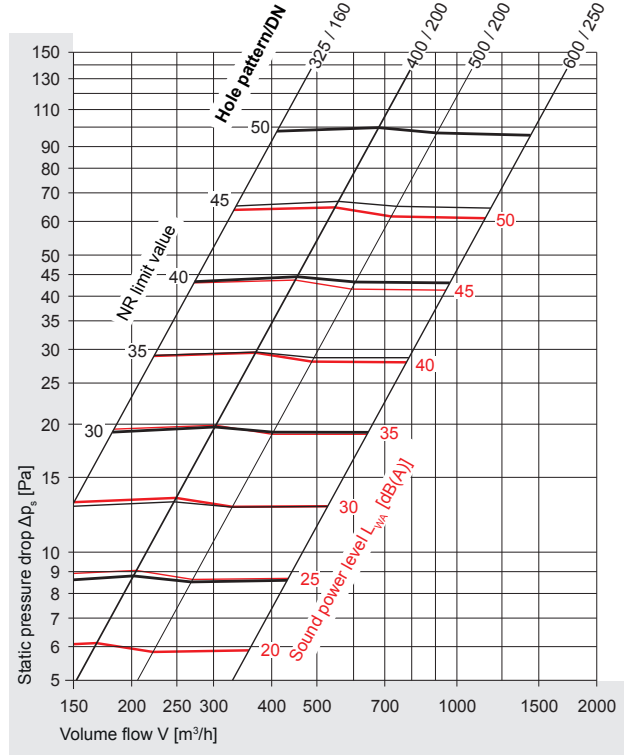

Supply air: DTR0 with plenum box R3-DL

with air deflector plate and damper OPEN

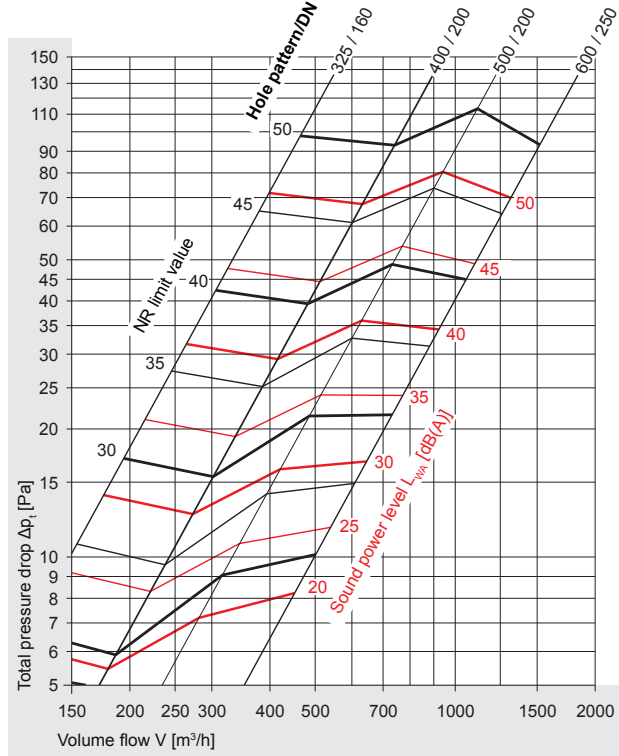

Exhaust air: DTR0 with plenum box R3-D

without air deflector plate and damper OPEN

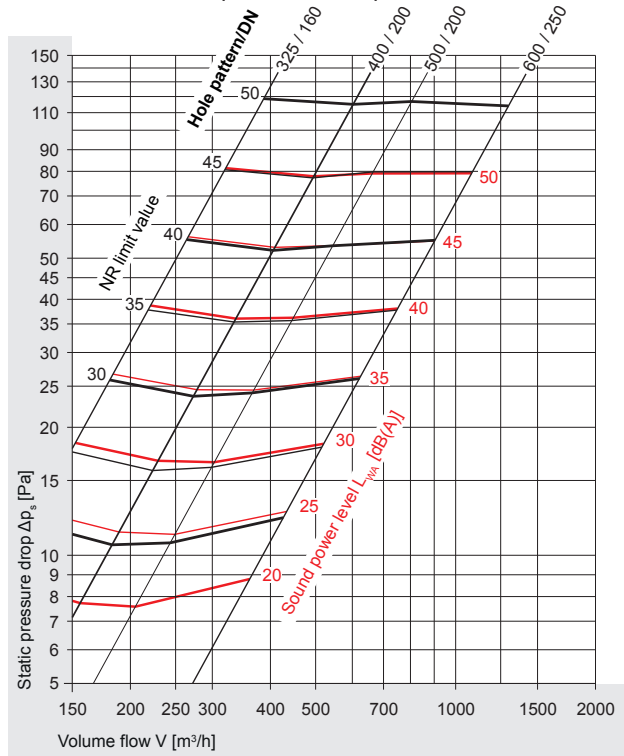

In addition, note the minimum volume flow rates!
⇒ see page 16

Corrections for other connecting piece sizes and for damper CLOSED ⇒ see pages 14, 15 and 16.
Relative sound power level ΔL for plenum boxes R1 and R3 ⇒ see WILDEBOER - dimensioning software.

DT swirl diffuser

Temperature ratio, induction, nomenclature

Temperature ratio, induction

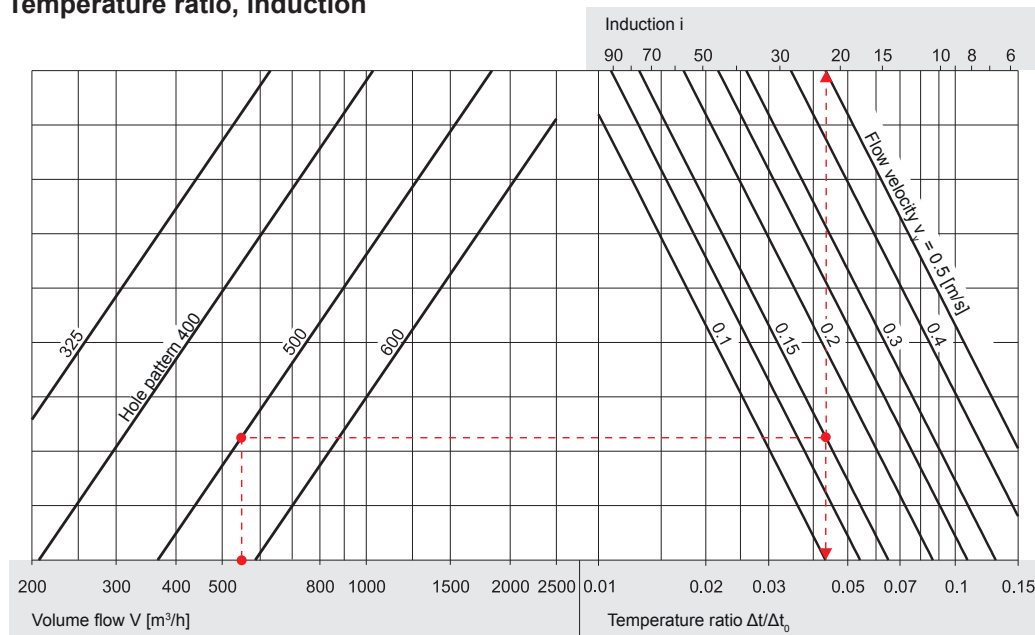

Example (⇒ see page 7)

DTQ0 - 500 - 500 - K1 - 200 - DL

Supply air volume flow	V	=	550	m³/h
Flow velocity	v _y	=	0.15	m/s
Room temperature	t _R	=	22	°C
Supply air temperature	t ₀	=	16	°C
Temperature ratio	Δt / Δt ₀	=	0,043	
Temperature	t _y	=	0,043 · (16 - 22) + 22	= 21.7 °C
Induction	i	=	22	
Secondary volume flow	V _s	=	22 · 550 m³/h	= 12100 m³/h

Nomenclature

A _{free}	[m²]	= Free cross-section of swirl diffuser	t _R	[°C]	= Room temperature
DN	[mm]	= Connecting piece size	Δt ₀	[K]	= Temperature difference; Δt ₀ = t ₀ - t _R
A _A	[m²]	= Inflow cross-section A _A = (DN [mm])² · π/4	Δt/Δt ₀		= Temperature ratio
V	[m³/h]	= Volume flow	i		= Induction
V _{tot.}	[m³/h]	= Total volume flow	V _s	[m³/h]	= Secondary volume flow; V _s = i · V
v _o	[m/s]	= Flow velocity in A _{free} v _o = V / (3600 · A _{free})	Δp _t	[Pa]	= Total pressure drop
v _A	[m/s]	= Flow velocity in A _A v _A = V / (3600 · A _A)	Δp _s	[Pa]	= Static pressure drop
v _y	[m/s]	= Flow velocity along air stream path	L _p	[dB]	= Sound pressure level
A, B	[m]	= Distance between two diffusers	L _{pA}	[dB(A)]	= A-weighted sound pressure level
W	[m]	= Distance of diffuser to wall	L _w	[dB]	= Sound power level
Y	[m]	= Distance from the ceiling	L _{wA}	[dB(A)]	= A-weighted sound power level
H	[m]	= Room height	L _{w-Oct}	[dB]	= Octave sound power level L _{w-Oct} = L _{wA} + ΔL
t _y	[°C]	= Temperature along air stream path t _y = (Δt/Δt ₀) · (t ₀ - t _R) + t _R	ΔL	[dB]	= relative sound power level to L _{wA}
t ₀	[°C]	= Supply air temperature	ΔL _R	[dB]	= Acoustic room attenuation
			f	[Hz]	= Octave mid frequency
			NR		= NR limit value relating to sound power
			NC		= NC limit value relating to sound power

DT swirl diffuser

Correction values: Plenum boxes with connecting piece sizes different to standard connecting pieces, damper OPEN

Connecting piece size		DN	100	125	150	160	180	200	224	250	280	300	315
Supply air Plenum box K1-DL with air deflector plate	Plenum box size 325	Δp	x	2.9	1.6	1.1	1.0	0.9	0.8	-	-	-	-
		L_{WA}	+	4.4	2.1	0.5	0.0	-0.9	-1.6	-	-	-	-
	400	Δp	x	-	2.8	1.7	1.5	1.2	1.0	0.9	-	-	-
		L_{WA}	+	-	8.2	4.8	3.7	1.7	0.0	-1.7	-	-	-
	500	Δp	x	-	-	2.3	1.9	1.3	1.0	0.8	0.6	0.5	-
		L_{WA}	+	-	-	7.0	5.3	2.5	0.0	-2.5	-4.8	-7.0	-
	600 ¹⁾	Δp	x	-	-	5.4	4.3	2.8	1.9	1.4	1.0	0.8	0.7
		L_{WA}	+	-	-	17.0	14.7	10.6	7.0	3.4	0.0	-3.3	-5.2
Exhaust air Plenum box K1-D without air deflector plate	Plenum box size 325	Δp	x	2.5	1.5	1.1	1.0	0.9	0.8	-	-	-	-
		L_{WA}	+	6.2	2.9	0.7	0.0	-1.1	-1.8	-	-	-	-
	400	Δp	x	-	3.4	1.9	1.6	1.2	1.0	0.9	-	-	-
		L_{WA}	+	-	10.5	5.9	4.5	2.0	0.0	-1.8	-	-	-
	500	Δp	x	-	-	2.4	2.0	1.3	1.0	0.8	0.6	0.5	-
		L_{WA}	+	-	-	8.3	6.3	2.8	0.0	-2.7	-5.0	-6.9	-
	600 ¹⁾	Δp	x	-	-	5.0	4.0	2.7	1.9	1.4	1.0	0.8	0.7
		L_{WA}	+	-	-	19.0	16.2	11.4	7.4	3.4	0.0	-3.1	-4.7
Supply air Plenum box K2-DL with air deflector plate	Plenum box size 325	Δp	x	1.0	-	-	-	-	-	-	-	-	-
		L_{WA}	+	0.0	-	-	-	-	-	-	-	-	-
	400	Δp	x	1.7	1.0	-	-	-	-	-	-	-	-
		L_{WA}	+	7.5	0.0	-	-	-	-	-	-	-	-
	500	Δp	x	-	2.5	1.5	1.3	1.0	-	-	-	-	-
		L_{WA}	+	-	9.5	4.3	2.7	0.0	-	-	-	-	-
	600 ¹⁾	Δp	x	-	5.1	2.8	2.2	1.6	1.2	1.0	-	-	-
		L_{WA}	+	-	20.4	12.9	10.4	6.3	3.1	0.0	-	-	-
Exhaust air Plenum box K2-D without air deflector plate	Plenum box size 325	Δp	x	1.0	-	-	-	-	-	-	-	-	-
		L_{WA}	+	0.0	-	-	-	-	-	-	-	-	-
	400	Δp	x	1.7	1.0	-	-	-	-	-	-	-	-
		L_{WA}	+	6.8	0.0	-	-	-	-	-	-	-	-
	500	Δp	x	-	2.4	1.4	1.2	1.0	-	-	-	-	-
		L_{WA}	+	-	9.8	4.6	2.9	0.0	-	-	-	-	-
	600 ¹⁾	Δp	x	-	4.7	2.6	2.1	1.6	1.2	1.0	-	-	-
		L_{WA}	+	-	21.1	13.6	11.2	6.9	3.4	0.0	-	-	-
Supply air Plenum box R1-DL with air deflector plate	Plenum box size 325	Δp	x	2.8	1.5	1.1	1.0	0.9	0.8	-	-	-	-
		L_{WA}	+	5.4	2.7	0.7	0.0	-1.1	-2.1	-	-	-	-
	400	Δp	x	-	3.1	1.8	1.5	1.2	1.0	0.9	-	-	-
		L_{WA}	+	-	6.0	3.5	2.6	1.2	0.0	-1.2	-	-	-
	500	Δp	x	-	-	2.4	1.9	1.3	1.0	0.8	0.6	0.5	-
		L_{WA}	+	-	-	5.8	4.4	2.0	0.0	-2.1	-3.9	-5.6	-
	600	Δp	x	-	-	5.6	4.4	2.9	2.0	1.4	1.0	0.8	0.7
		L_{WA}	+	-	-	15.3	13.2	9.5	6.3	3.0	0.0	-2.9	-4.6
Exhaust air Plenum box R1-D without air deflector plate	Plenum box size 325	Δp	x	2.9	1.6	1.1	1.0	0.9	0.8	-	-	-	-
		L_{WA}	+	8.4	4.3	1.1	0.0	-2.0	-3.7	-	-	-	-
	400	Δp	x	-	3.0	1.8	1.6	1.2	1.0	0.8	-	-	-
		L_{WA}	+	-	9.7	5.8	4.5	2.1	0.0	-2.2	-	-	-
	500	Δp	x	-	-	2.5	2.0	1.4	1.0	0.7	0.6	0.5	-
		L_{WA}	+	-	-	7.6	5.9	2.7	0.0	-2.9	-5.5	-8.2	-
	600	Δp	x	-	-	6.3	4.9	3.1	2.1	1.4	1.0	0.7	0.6
		L_{WA}	+	-	-	17.3	15.0	10.9	7.3	3.5	0.0	-3.5	-5.6

The correction values are mean values for the whole volume flow range, otherwise see WILDEBOER dimensioning software.

¹⁾ Plenum box size 600 is for swirl diffusers of nominal sizes 600 and 625 (hole pattern 600).

DT swirl diffuser

Correction values: Plenum boxes K1, K2 and R1 with damper CLOSED

Connecting piece size		DN	100	125	150	160	180	200	224	250	280	300	315	
Supply air Plenum box K1-DL with air deflector plate	Plenum box size 325	Δp	x 3.6	3.0	2.5	2.2	1.8	1.4	-	-	-	-	-	
		L_{WA}	+ 15.7	8.2	3.5	2.3	1.2	1.8	-	-	-	-	-	
	400	Δp	x -	4.0	3.1	2.8	2.3	2.0	1.7	-	-	-	-	
		L_{WA}	+ -	13.9	10.1	8.7	6.3	4.2	2.2	-	-	-	-	
	500	Δp	x -	-	4.1	3.9	3.5	3.2	2.8	2.5	2.1	-	-	
		L_{WA}	+ -	-	14.9	13.8	11.7	9.8	7.9	6.1	4.6	-	-	
	600 ¹⁾	Δp	x -	-	4.5	4.4	4.3	4.1	3.8	3.4	2.9	2.6	2.3	
		L_{WA}	+ -	-	16.3	15.8	14.8	13.7	12.2	10.6	8.6	7.2	6.1	
	Exhaust air Plenum box K1-D without air deflector plate	Plenum box size 325	Δp	x 3.0	2.5	2.0	1.8	1.6	1.4	-	-	-	-	-
			L_{WA}	+ 13.4	8.5	5.0	4.0	2.7	2.3	-	-	-	-	-
		400	Δp	x -	2.7	2.6	2.6	2.4	2.2	1.7	-	-	-	-
			L_{WA}	+ -	10.6	10.0	9.5	8.3	6.5	3.9	-	-	-	-
500		Δp	x -	-	3.0	3.0	2.8	2.6	2.4	2.2	1.9	-	-	
		L_{WA}	+ -	-	12.7	12.0	10.6	9.4	8.2	7.2	6.4	-	-	
600 ¹⁾		Δp	x -	-	3.5	3.4	3.3	3.2	3.1	2.9	2.6	2.3	-	
		L_{WA}	+ -	-	14.0	13.8	13.5	13.0	12.4	11.5	10.4	9.6	8.9	
Supply air Plenum box K2-DL with air deflector plate		Plenum box size 325	Δp	x 3.0	-	-	-	-	-	-	-	-	-	-
			L_{WA}	+ 9.1	-	-	-	-	-	-	-	-	-	-
		400	Δp	x 4.2	4.0	-	-	-	-	-	-	-	-	-
			L_{WA}	+ 13.8	12.7	-	-	-	-	-	-	-	-	-
	500	Δp	x -	4.8	3.8	3.4	2.6	-	-	-	-	-	-	
		L_{WA}	+ -	16.7	12.3	10.5	7.1	-	-	-	-	-	-	
	600 ¹⁾	Δp	x -	5.1	4.2	3.8	3.3	2.8	2.3	-	-	-	-	
		L_{WA}	+ -	16.6	12.8	11.6	9.4	7.7	6.4	-	-	-	-	
	Exhaust air Plenum box K2-D without air deflector plate	Plenum box size 325	Δp	x 2.6	-	-	-	-	-	-	-	-	-	-
			L_{WA}	+ 9.9	-	-	-	-	-	-	-	-	-	-
		400	Δp	x 3.5	3.2	-	-	-	-	-	-	-	-	-
			L_{WA}	+ 12.8	12.5	-	-	-	-	-	-	-	-	-
500		Δp	x -	4.7	3.6	3.1	2.2	-	-	-	-	-	-	
		L_{WA}	+ -	16.9	12.6	10.9	7.5	-	-	-	-	-	-	
600 ¹⁾		Δp	x -	4.4	3.5	3.2	2.7	2.2	1.9	-	-	-	-	
		L_{WA}	+ -	14.9	12.4	11.6	10.0	8.8	7.6	-	-	-	-	
Supply air Plenum box R1-DL with air deflector plate		Plenum box size 325	Δp	x 3.5	3.3	2.8	2.6	2.1	1.5	-	-	-	-	-
			L_{WA}	+ 16.6	11.3	7.1	5.7	3.4	1.7	-	-	-	-	-
		400	Δp	x -	5.1	3.8	3.4	2.8	2.3	2.1	-	-	-	-
			L_{WA}	+ -	19.4	10.2	7.5	3.7	2.0	2.9	-	-	-	-
	500	Δp	x -	-	4.5	4.5	4.5	4.3	4.0	3.3	2.3	-	-	
		L_{WA}	+ -	-	18.2	17.1	14.9	12.7	10.1	7.2	3.9	-	-	
	600	Δp	x -	-	5.1	5.0	4.9	4.7	4.4	4.0	3.5	3.2	2.9	
		L_{WA}	+ -	-	20.3	19.7	18.4	17.0	15.0	12.7	9.6	7.3	5.5	
	Exhaust air Plenum box R1-D without air deflector plate	Plenum box size 325	Δp	x 2.7	2.5	2.2	2.1	1.8	1.4	-	-	-	-	-
			L_{WA}	+ 12.0	8.3	5.5	4.5	3.1	2.1	-	-	-	-	-
		400	Δp	x -	3.8	3.2	3.0	2.5	2.1	1.6	-	-	-	-
			L_{WA}	+ -	18.9	13.7	12.0	8.9	6.4	4.2	-	-	-	-
500		Δp	x -	-	2.9	3.0	3.1	3.0	2.9	2.5	1.9	-	-	
		L_{WA}	+ -	-	13.8	13.2	11.9	10.8	9.4	8.0	6.4	-	-	
600		Δp	x -	-	3.4	3.4	3.4	3.4	3.3	3.1	2.8	2.5	2.2	
		L_{WA}	+ -	-	17.2	16.8	16.0	15.1	13.9	12.5	10.9	9.7	8.7	

The correction values are mean values for the whole volume flow range, otherwise see WILDEBOER dimensioning software.

¹⁾ Plenum box size 600 is for swirl diffusers of nominal sizes 600 and 625 (hole pattern 600).

DT swirl diffuser

Correction values, limit curves, room acoustics, area of application

Correction values: Plenum boxes K3 and R3 with damper CLOSED

Plenum box size	DN		K3		R3	
			Supply air	Exhaust air	Supply air	Exhaust air
325	160	Δp x	2.8	2.1	2.3	2.0
		L_{WA} +	7.3	8.7	4.7	9.7
400	200	Δp x	2.6	2.0	2.4	2.0
		L_{WA} +	5.9	7.7	4.7	9.7
500	200	Δp x	4.0	2.5	3.7	2.5
		L_{WA} +	17.2	11.0	14.4	11.7
600 ¹⁾	250	Δp x	3.6	2.6	3.5	2.5
		L_{WA} +	16.2	11.6	16.0	13.1

The correction values are mean values for the whole volume flow range, otherwise see WILDEBOER dimensioning software.

¹⁾ Plenum box size 600 is for swirl diffusers of nominal sizes 600 and 625 (hole pattern 600).

Acoustic limit values NR, NC

The NR limit values given in the nomograms according to ISO 1996 are calculated from octave sound power levels and not in relation to sound pressure levels. The room attenuation ΔL_R is not taken into account. It depends individually on the acoustics of the room. NC limit values should be related like NR limit values to the sound pressure level. In the application area of ventilation and air conditioning, NC may be roughly estimated at $NC = NR - 4$.

Room attenuation ΔL_R

The nomograms give individual sound power levels. The sum of all the sound pressure levels should be used for the acoustic rating. It differs from the the sum of individual sound power levels by the room attenuation. $L_p, L_{pA} = L_w, L_{wA} + \Delta L_R$. In ventilation and air conditioning systems, ΔL_R can be approximately estimated as equal to - 8 [dB].

Area of application

Plenum boxes installed flush in ceilings are required for optimum air distribution in rooms with heights of approximately 2.5 to 4 m. DT swirl diffusers then divide the supply air radially below the ceilings. Air is deflected into the occupied zone by room walls and counterflows. In the case of cooling, the minimum flow rates should be maintained at a given temperature differential Δt_0 between the supply air and room air. A partial drop of cold air by way of stratification, which is associated with draught in the occupied zone, is prevented, and may otherwise occur when cold air is introduced into the room at a higher temperature.

There are generally always minimum volume flow rates to ensure minimum room ventilation, even in heating mode and under isothermal conditions with $\Delta t_0 = 0$ K.

Thermally induced deflections occur with a freely suspended installation. In this respect, the supply air penetrating into the occupied zone can be expected with changed flow velocities. Comfort criteria can therefore only be satisfied to a limited extent with this type of installation.

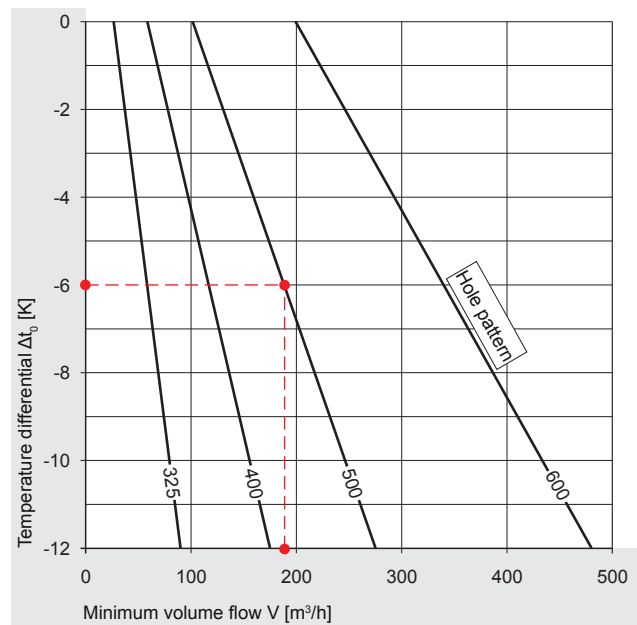

Example (⇒ see page 7)

DTQ0 - 500 - 500 - K1 - 200 - DL

Room temperature	t_r	=	22 °C
Supply air temperature	t_0	=	16 °C
Temperature differential	Δt_0	=	- 6 K
Minimum volume flow (supply air)	V	=	190 m³/h

NOTE

The **minimum volume flow rates** specified according to temperature must also be observed when designing with the nomogram or tables! This can be factored in automatically with the WILDEBOER dimensioning software!

DT swirl diffuser

Quick selection

Volume flow [m³/h] / pressure drop [Pa]

Connecting piece size DN	Plenum box size		Sound power level [dB(A)]						
			20	25	30	35	40	45	50
Supply air DTQ0 with plenum box K1-DL with air deflector plate Damper OPEN	325	100	100 / 13	120 / 19	150 / 30	180 / 43	220 / 65	270 / 98	330 / 146
		160	120 / 7	140 / 9	170 / 14	210 / 21	260 / 32	320 / 48	390 / 71
	400	200	130 / 7	150 / 9	190 / 14	230 / 20	280 / 30	340 / 44	410 / 65
		200	140 / 9	180 / 16	210 / 21	260 / 33	320 / 49	390 / 73	480 / 111
	500	125	200 / 7	240 / 10	300 / 15	360 / 22	440 / 33	540 / 49	660 / 74
		224	220 / 7	260 / 10	320 / 15	390 / 22	470 / 32	570 / 48	700 / 72
	600 ¹⁾	150	210 / 9	250 / 13	310 / 20	380 / 31	460 / 45	560 / 66	680 / 98
		200	270 / 7	330 / 10	410 / 15	500 / 23	600 / 33	740 / 50	900 / 73
	In addition, Adhere to the minimum volume flow rates! ⇒ see page 16	280	370 / 7	450 / 10	540 / 14	660 / 21	800 / 31	960 / 45	1170 / 67
		250	220 / 9	270 / 14	320 / 19	400 / 30	480 / 43	590 / 65	720 / 97
	315	430 / 6	520 / 9	630 / 14	770 / 21	930 / 30	1130 / 44	1380 / 66	
Exhaust air DTQ0 with plenum box K1-D without air deflec- tor plate Damper OPEN	325	100	80 / 9	100 / 14	130 / 24	150 / 32	190 / 52	230 / 76	290 / 121
		160	110 / 7	130 / 10	160 / 15	200 / 23	240 / 33	300 / 51	360 / 74
	400	200	120 / 7	150 / 11	180 / 15	210 / 21	260 / 32	320 / 48	380 / 68
		200	120 / 9	150 / 14	180 / 21	220 / 31	270 / 47	330 / 70	400 / 103
	500	125	190 / 7	230 / 10	270 / 14	330 / 20	410 / 32	490 / 45	600 / 68
		224	200 / 6	250 / 10	300 / 14	360 / 21	440 / 31	530 / 45	640 / 66
	600 ¹⁾	150	180 / 9	210 / 12	260 / 18	320 / 28	390 / 41	480 / 63	580 / 91
		200	250 / 7	300 / 10	370 / 15	440 / 22	540 / 32	650 / 47	790 / 69
	In addition, Adhere to the minimum volume flow rates! ⇒ see page 16	280	340 / 7	400 / 9	490 / 14	590 / 20	710 / 29	850 / 42	1020 / 60
		250	190 / 8	230 / 12	280 / 17	340 / 26	410 / 37	510 / 58	620 / 86
	315	400 / 7	480 / 10	580 / 15	700 / 22	850 / 32	1020 / 46	1230 / 67	
		510 / 7	610 / 10	730 / 14	880 / 21	1050 / 30	1260 / 43	1510 / 62	

Standard connecting pieces of plenum boxes K1 are in bold.

¹⁾ Plenum box size 600 is for swirl diffusers of nominal sizes 600 and 625 (hole pattern 600).

DT swirl diffusers

- meet the **hygiene requirements** according to VDI 6022-1, VDI 3803-1, DIN 1946-4, DIN EN 13779.
- are **resistant to microbes**, and therefore **do not promote the growth of micro-organisms (fungi, bacteria)**. This reduces the risk of infection for people and also the necessary cleaning and disinfection work!
- are **resistant to cleaning agents and disinfectants** and are suitable for use in hospitals and similar facilities!

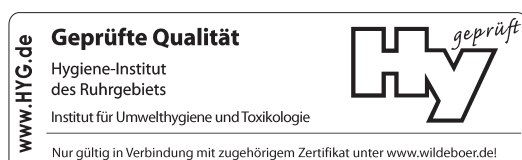

DT swirl diffuser

Order information

		DT	0	-	-	-	-	-	-	-	-	-	-
Front plate:													
square	Q												Connecting piece
circular	R												LD with lip seal
⇒ see page 3													
Nominal size													Plenum box design
325													VK galvanized
400													KL²⁾ outside in RAL
500													SK black inside and outside
600													
625 ³⁾													Built-in components
													D with damper
													L with air deflector plate
													DL with damper and air deflector plate
Hole pattern (Plenum box size)													Connecting piece size DN... ⇒ see pages 4 and 5
325													
400													
500													
600													
Colour													Plenum box
Front plate RAL 9010													square
Cap RAL 9010	ST¹⁾												K1 one side-entry connecting piece
Front plate RAL													K2 two side-entry connecting pieces
Cap RAL 9017 (black)	FL²⁾												K3 top-entry connecting piece
Front plate RAL													circular
Cap accordingly	FS²⁾												R1 one side-entry connecting piece
													R3 top-entry connecting piece

¹⁾ standard colour
²⁾ specify in addition to RAL colour
³⁾ only with square front panel

Example: DTQ0 - 500 - 500 - ST - K1 - 200 - DL - VK - LD

NOTE concerning colours

Colour variations should never be totally avoided for technical reasons; this is particularly the case for colours RAL 9006 (white aluminium) and RAL 9007 (grey aluminium). A special colour matching is advisable in particular instances, and in conjunction with surrounding colours, for example, suspended ceilings!

Connecting piece

with lip seal

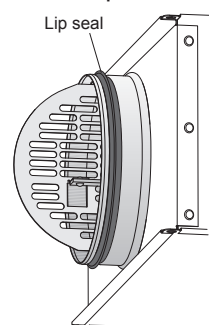

DT swirl diffuser

Specification text

DT swirl diffuser for supply air and exhaust air. For constant and variable volume flow rates. With progressively twisted blade profile for large volume flow rates with low flow noise. With high induction for reducing flow velocities and temperature differentials during heating and during room cooling up to -12 K using radial and axially symmetrical air distribution. Square/circular front panel made of galvanized sheet steel with fixed, radially aligned and progressively twisted air deflection blades and concealed central fastening. With resistant, colour-fast, anti-static polyester coating, smooth glossy in colour RAL 9010 (white) or in RAL special colour.

Certificate of conformity as proof of compliance with the hygiene requirements according to VDI 6022-1, VDI 3803-1, DIN 1946-4 and DIN EN 13779.

Plenum box with central attachment, made from galvanized sheet steel with holes for suspensions with

- special air deflector plate, in particular for supply air, for optimum air distribution with low flow noise
- with powder coating on inside and outside
- in RAL special colour on outside
- one side-entry connecting piece
- two side-entry connecting pieces
- top-entry connecting piece
- Lip seal(s)
- Damper for adjusting volume flow without dismantling the air outlet

Installation in closed ceiling systems, grid ceilings and freely suspended.

..... pc

Volume flow:	m³/h	
Pressure drop:	Pa	
Sound power level:	dB (A)	
Manufacturer:	WILDEBOER®		
Type:	DT		
Nominal size:		
Hole pattern:		
Connecting piece size DN:		
Colour of swirl diffuser:	RAL.....		
Colour of plenum box:	RAL.....		
complete with fixings		deliver:
		install:

Select texts not highlighted in bold as required!

INNOVATIVE • PRACTICAL • ECONOMICAL

WILDEBOER®

Factory - Administration
Telephone: +49 (0)4951 - 950 - 0
Fax: +49 (0)4951 - 950 - 27120
E-mail: info@wildeboer.de
Internet: www.wildeboer.eu

WILDEBOER®

Utrecht office
Telephone: +31 30 767 0150
E-mail: info@utrecht.wildeboer.eu

WILDEBOER®

Ulm office
Telephone: +49 (0)7392 - 9692 - 0
Fax: +49 (0)4951 - 950 - 27299
E-mail: info@ulm.wildeboer.de

WILDEBOER®

LEIPZIG

Leipzig office
Telephone: +49 (0)34444 - 310 - 0
Fax: +49 (0)4951 - 950 - 27298
E-mail: info@leipzig.wildeboer.de

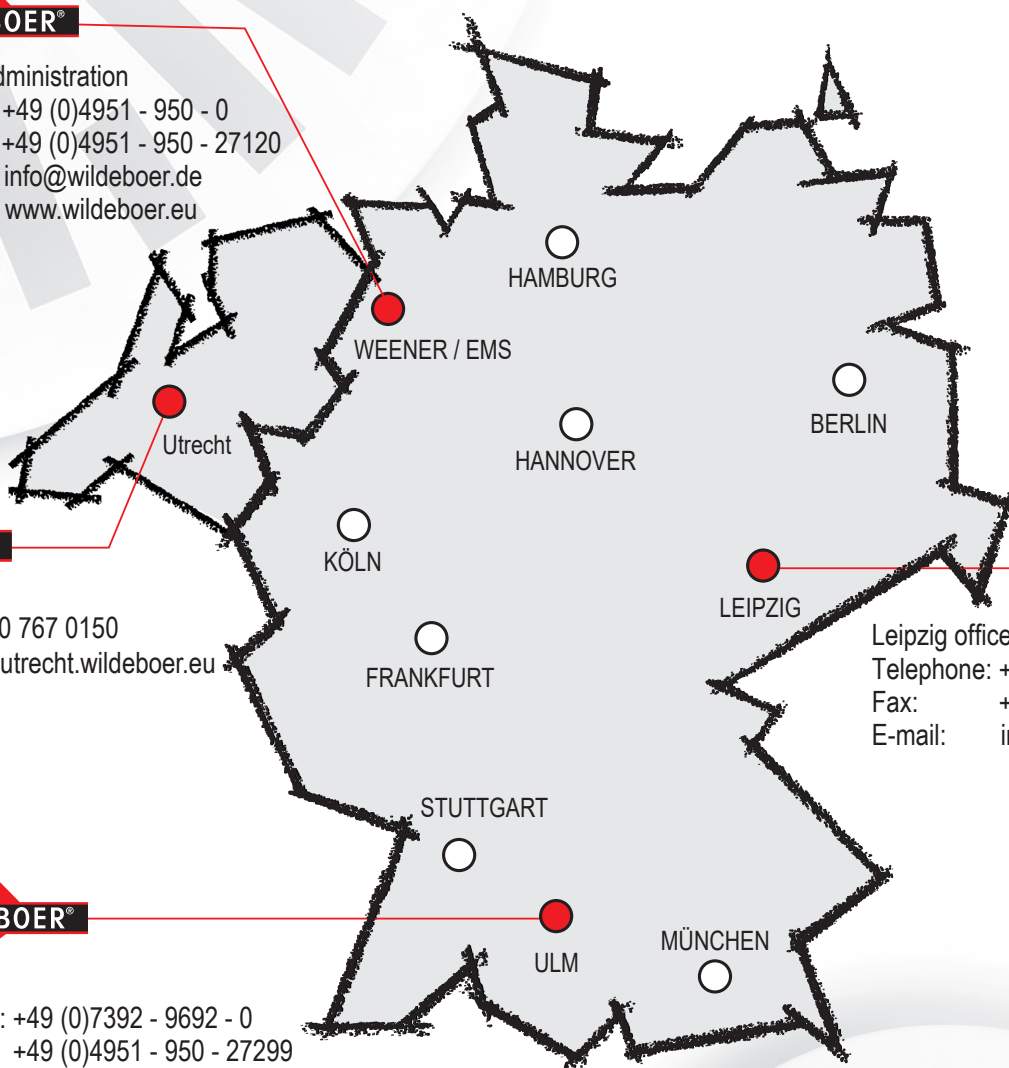

TAKE ADVANTAGE OF OUR STRENGTHS!

WILDEBOER®

COMPONENTS FOR VENTILATION + AIR CONDITIONING

air distribution fire protection noise protection

building control systems