



Maintenance-free, electronic

VRE1 volume flow controller

for ventilation and air conditioning systems. Versatile.

- Sizes DN 100 to DN 400.
- Operating voltage: 24 V AC/DC.
- Operation modes: Constant, 4-point, Variable (0 – 10 V, 2 – 10 V, 2 – 8 V).
- Leak tightness classes according to DIN EN 1751: Casing C, shut-off damper 3 and 4.
- Measuring device integrated into the damper blade. Outstanding control accuracy.
- Displays and settings are carried out digitally, also using a PC.
- Efficiency signal for optimising the fan output during operation.
- Overrides for complete opening and closing.

VRE1 volume flow controller

Properties



VRE1 volume flow controllers measure the volume flow directly at the damper blade.

The duct casing is free of disrupting measuring leads and other inbuilt parts which results in large unobstructed cross-sections. The flow does not pass through the measuring device! It is therefore immune to noise.

The **motorised actuator M1** is equipped with plain text displays, an illuminated display and adjustment buttons. LED status displays provide information on the current operating status of the volume flow controller at all times using different colours and signal types.

In addition, all settings and displays can be transferred to a PC via the RS232 interface located on the front, where they can be viewed and executed.

The **motorised actuator M2** is not equipped with plain text displays, display, adjustment buttons and LED status displays. The settings and displays are carried out using a PC via the RS232 interface.

Settings can also be made and ordered **at the factory**. Changes can be made on site via the adjustment buttons or using a PC.

Option

VRE1 volume flow controller with acoustic insulation for thermal insulation and reduction of sound radiation to the outside.



Strain-relieved, assembly-optimised connection plug.

All illustrations show VRE1 volume flow controllers with motorised actuator M1 and lip seals.

Option

SRC duct silencer for volume flow controller for reduction of flow noise in the ventilation duct.

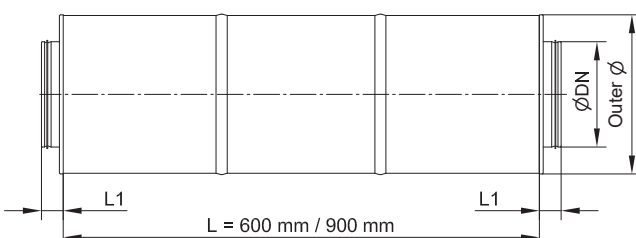

Maximum possible reduction of flow noise

Sound attenuator length

Size DN	Outer diameter Ø [mm]	L1 [mm]	L [mm]	
			600	900
100	200	40	-27 dB	-31 dB
125	225	40	-25 dB	-28 dB
160	260	40	-22 dB	-26 dB
200	300	40	-20 dB	-25 dB
250	355	40	-18 dB	-22 dB
315	415	40	-16 dB	-20 dB
400	500	65	-	-20 dB

VRE1 volume flow controller

Description / technical data (1)

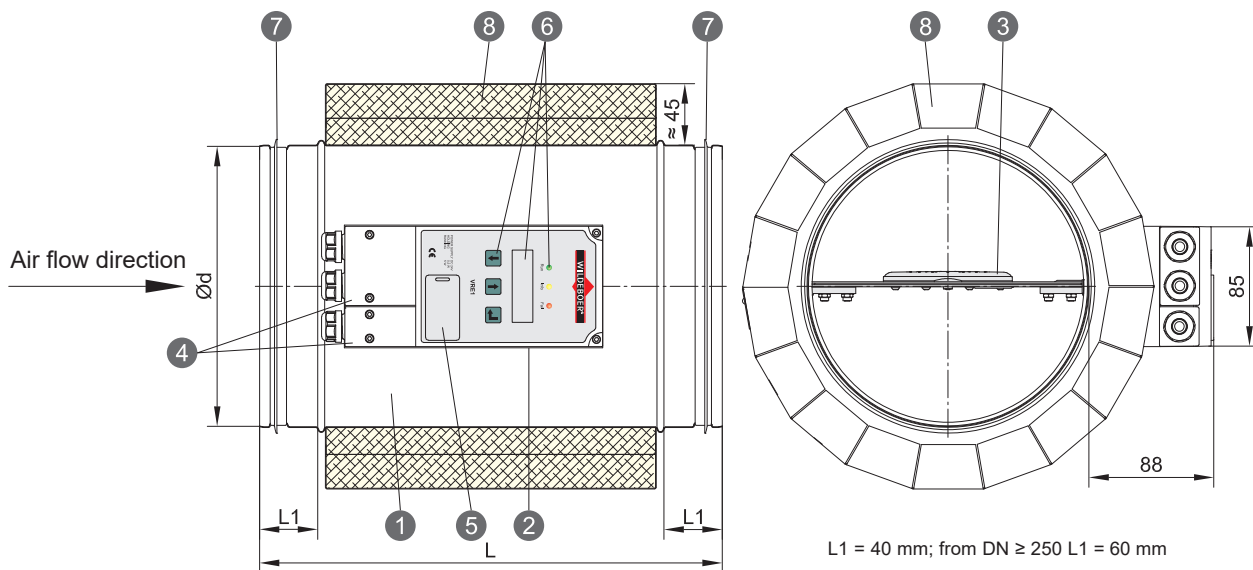

VRE1 volume flow controllers are maintenance-free, electronic controllers that produce constant and variable volume flows in ventilation and air conditioning systems.

They can be installed in supply and exhaust air ventilation ducts and are not position sensitive. The housing and control mechanism are made of galvanized sheet steel. Damper blade for volume flow control, positioned centrally with peripheral gasket. Stainless steel bearing shafts in special bearing bushes. Actuator M1 with display, adjustment buttons and LED status displays, M2 for adjustment only via PC.

Operation modes: “Constant”, “4-point 24 V AC/DC”, “Variable 0 – 10 V DC”, “Variable 2 – 10 V DC”, “Variable 2 – 8 V DC” and the overrides “Damper blade fully open” and “Damper blade closed”. Parallel operation and sequential circuits. Efficiency signal for optimising the fan output during operation.

The innovative measurement procedure ensures high control accuracy at all pressures in approx. 1:10 volume flow ranges V_{min} to V_{max} with only $\pm 5\%$ to $\pm 15\%$ deviation from the reference volume flow. Accordingly, the volume flows throughout the entire pressure range are kept constant.

- Sizes: DN 100 – DN 400
- Total volume flow range: 34 – 5430 m³/h
- Pressure control range: 20 – 1000 Pa
- Operating voltage: 24 V AC/DC
- *Options*
 - Acoustic insulation with sheet metal jacket on the outside
 - Lip seals on both sides
 - Factory settings \Rightarrow see page 14
 - SRC duct silencer, 600 mm and 900 mm lengths

VRE1 volume flow controllers

- satisfy the **hygiene requirements** in accordance with VDI 6022-1, VDI 3803-1, DIN 1946-4, DIN EN 13779, SWKI VA104-01, SWKI 99-3, ÖNORM H6020 and ÖNORM H6021.
- are **resistant to microbes**, and therefore **do not promote the growth of micro-organisms (fungi, bacteria)**. This reduces the risk of infection for people and also expenditure for cleaning and disinfection!
- are **resistant to cleaning agents and disinfectants** and are suitable for use in hospitals and similar facilities!
- with **Environmental Product Declaration** according to ISO 14025 and EN 15804: EPD-WIL-20150036-ICA1-DE.

- 1 Duct casing.
- 2 Motorised actuator M1.
- 3 Damper blade with integrated measuring cell.
- 4 Connection plug with integrated strain relief.
- 5 RS232 interface for PC.
- 6 Illuminated display with plain text displays, LED status displays and buttons for making adjustments (only actuator M1).
- 7 Lip seal (*optional*).
- 8 Acoustic insulation with sheet metal jacket (*optional*).

Size	V_{min}	V_{max}	$\varnothing d$	L	A_A
DN	[m ³ /h]	[m ³ /h]	[mm]	[mm]	[m ²]
100	34	340	99	329	0.008
125	53	530	124	329	0.012
160	87	870	159	329	0.020
200	136	1360	199	329	0.031
250	212	2120	249	406	0.049
315	337	3370	314	456	0.078
400	543	5430	399	551	0.126

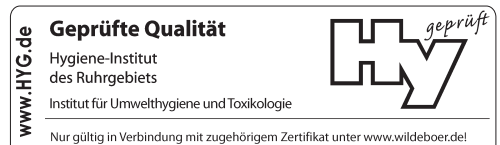

VRE1 volume flow controller

Technical data (2) / operation modes

Other technical data

- Flow velocity in A_A
 $v_A = 1.2 - 12 \text{ m/s}$
- Maximum differential pressure:
2000 Pa
- Leak tightness according to
DIN EN 1751:
 - Casing: Class C
 - Damper blade:
 - Class 3: DN 100 and DN 125
 - Class 4: DN 160 to DN 400
- Temperature ranges
 - Inside $+5 - +60^\circ\text{C}$
 - Outside $+5 - +50^\circ\text{C}$
- Maximum humidity 80%, non-con-
densing.
- Operating voltage: 24 V AC/DC $\pm 20\%$
- Power consumption:
 - holding: 1.2 VA, 0.5 W
 - running: 3.5 VA, 1.5 W
- Degree of protection IP 54
- Runtime for 90° approx. 90 s
- EMC CE in accordance with
2004/108/EC

Nomenclature

V	[m³/h]	Volume flow
V_{\min}	[m³/h]	Minimum adjustable volume flow
V_{\max}	[m³/h]	Maximum adjustable volume flow
V_{\min} to V_{\max}		Operating range of volume flow controller
V_{ref} , OVF_{const} , OVF_{min} , OVF_{max} , OVF_{mid1} , OVF_{mid2}	[m³/h]	Reference volume flows
LVF_{min}	[m³/h]	Minimum adjustable reference volume flow
v_A	[m/s]	Flow velocity in A_A
A_A	[m²]	Inflow cross-section $A_A = \pi/4 \cdot DN^2$
Δp_S	[Pa]	Static pressure drop
L_{WA}	[dB(A)]	A-weighted sound power level
L_p	[dB]	Sound pressure level
$L_{p(A)}$	[dB(A)]	A-weighted sound pressure level
U	[V]	Reference signal (variable set point input)

Function of operation modes

- **Constant:** With $V_{\min} \leq OVF_{\text{const}} \leq V_{\max}$, a reference volume flow is set. The purpose of this is to keep the controller constant.
- **Variable:** With $OVF_{\text{min}} \geq LVF_{\text{min}} = 0.4 \cdot V_{\min}$ or $OVF_{\text{min}} = 0 \text{ m}^3/\text{h}$ and $OVF_{\text{max}} \geq 30\% V_{\max}$, a reference volume flow range is set. Volume flows V_{ref} can be specified within this range via reference signals U that can be kept constant by the controller from V_{\min} .

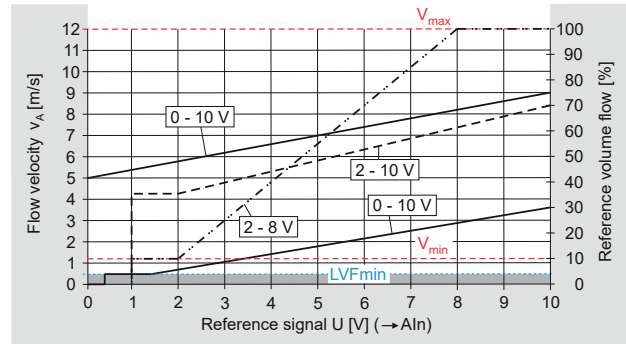

The following reference signals are possible:

0 – 10 V

- If $OVF_{\text{min}} = 0 \text{ m}^3/\text{h}$ is set, the damper blade closes completely with $U = 0$ to 0.4 V . The control function starts from $U \geq 0.4 \text{ V}$ at a volume flow $LVF_{\text{min}} = 0.4 \cdot V_{\min}$.
- If $OVF_{\text{min}} > 0 \text{ m}^3/\text{h}$ is set, the control function starts from $U = 0 \text{ V}$ at this value – without closing.

Calculating the reference volume flow V_{ref} for the reference signal U^* :

$$V_{\text{ref}} [\text{m}^3/\text{h}] = OVF_{\text{min}} [\text{m}^3/\text{h}] + (OVF_{\text{max}} [\text{m}^3/\text{h}] - OVF_{\text{min}} [\text{m}^3/\text{h}]) \cdot U [\text{V}] : 10 \text{ V [1]}$$

2 – 10 V

- If $0 \text{ V} \leq U < 1 \text{ V}$, the damper blade closes completely. If $1 \text{ V} \leq U \leq 2 \text{ V}$, the control function starts with OVF_{min} .
- If $OVF_{\text{min}} = 0 \text{ m}^3/\text{h}$ is set and $U \geq 1 \text{ V}$, the control function starts at the volume flow $LVF_{\text{min}} = 0.4 \cdot V_{\min}$.

Calculating the reference volume flow V_{ref} for the reference signal U^* :

$$V_{\text{ref}} [\text{m}^3/\text{h}] = OVF_{\text{min}} [\text{m}^3/\text{h}] + (OVF_{\text{max}} [\text{m}^3/\text{h}] - OVF_{\text{min}} [\text{m}^3/\text{h}]) \cdot (U [\text{V}] - 2 \text{ V}) : 8 \text{ V [2]}$$

2 – 8 V

- If $9 \text{ V} < U \leq 10 \text{ V}$, the damper blade opens completely. If $8 \text{ V} \leq U \leq 9 \text{ V}$, the control function operates with OVF_{max} . For $0 \text{ V} \leq U \leq 2 \text{ V}$, the functions are the same as those described for $U = 2$ to 10 V .

Calculating the reference volume flow V_{ref} for the reference signal U^* :

$$V_{\text{ref}} [\text{m}^3/\text{h}] = OVF_{\text{min}} [\text{m}^3/\text{h}] + (OVF_{\text{max}} [\text{m}^3/\text{h}] - OVF_{\text{min}} [\text{m}^3/\text{h}]) \cdot (U [\text{V}] - 2 \text{ V}) : 6 \text{ V [3]}$$

- **4-point** With OVF_{min} and OVF_{max} and the intermediate values OVF_{mid1} , OVF_{mid2} , four volume flows between V_{\min} and V_{\max} can be set and kept constant. The selection is made with LOW and HIGH signals (0 V and 24 V AC/DC).

Control	DigIn1 Terminal 6	DigIn2 Terminal 7	DigIn3 Terminal 8
OVF_{min}		LOW	LOW
OVF_{mid1}	LOW	LOW	HIGH
OVF_{mid2}		HIGH	LOW
OVF_{max}		HIGH	HIGH
open	HIGH	LOW	uninflu-
close		HIGH	ential

For terminal assignment \Rightarrow see page 12

Open/close **override**: The damper

blade can be fully opened and closed with LOW and HIGH signals. All operation modes are overridden during this process.

*) Volume flows in % V_{\max} can also be used instead of in m^3/h .
 \Rightarrow see examples on pages 6 and 7

VRE1 volume flow controller

Actual volume flow / efficiency signal for optimising the fan output during operation

Output signal AOut1: Actual volume flow V_{act}

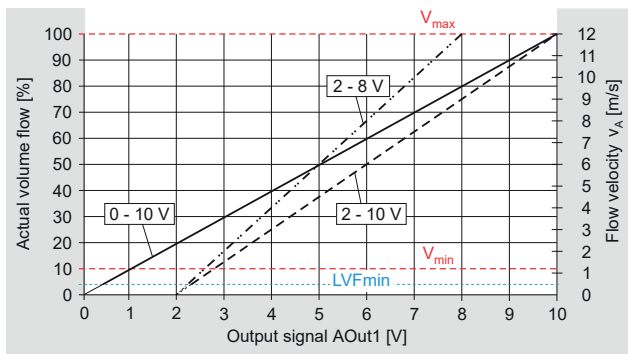

If the pressure upstream of the volume flow controller is insufficient, because the fan output is not high enough for example, nDef appears on the display. AOut1 then remains at the previous value.

Output signal AOut2: Efficiency signal

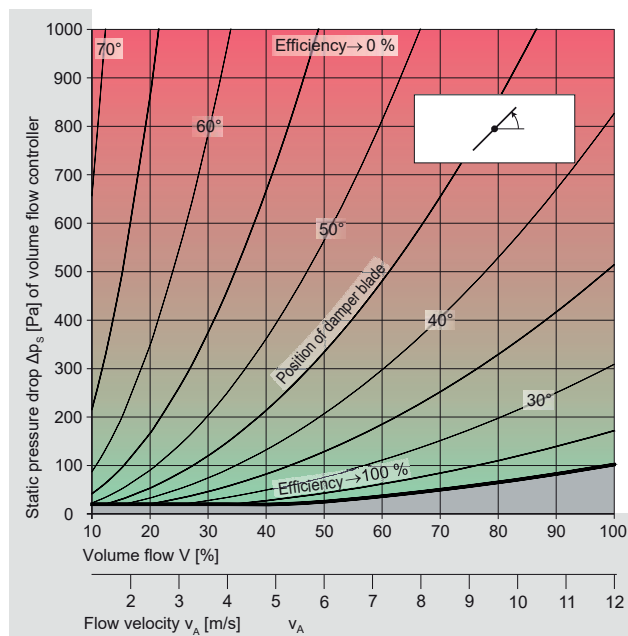
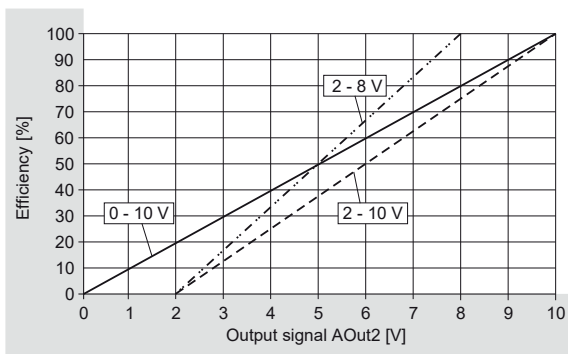

For **external volume flow display** and as reference signal for **sequential circuits**, the output signal **AOut1** which is proportional to the actual volume flow V_{act} is available at output 1, terminal 3.

Irrespective of the settings at the volume flow controller, the signal produced is proportional to the maximum volume flow V_{max} and reference signal U at:

$$0 - 10 \text{ V: } V_{act} [\text{m}^3/\text{h}] = V_{max} [\text{m}^3/\text{h}] \cdot \text{AOut1 [V]} : 10 \text{ V} \quad [1a]$$

$$\text{AOut1 [V]} = 10 \text{ V} \cdot V_{act} [\text{m}^3/\text{h}] : V_{max} [\text{m}^3/\text{h}] \quad [1b]$$

$$2 - 10 \text{ V: } V_{act} [\text{m}^3/\text{h}] = V_{max} [\text{m}^3/\text{h}] \cdot (\text{AOut1 [V]} - 2 \text{ V}) : 8 \text{ V} \quad [2a]$$

$$\text{AOut1 [V]} = 2 \text{ V} + 8 \text{ V} \cdot V_{act} [\text{m}^3/\text{h}] : V_{max} [\text{m}^3/\text{h}] \quad [2b]$$

$$2 - 8 \text{ V: } V_{act} [\text{m}^3/\text{h}] = V_{max} [\text{m}^3/\text{h}] \cdot (\text{AOut1 [V]} - 2 \text{ V}) : 6 \text{ V} \quad [3a]$$

$$\text{AOut1 [V]} = 2 \text{ V} + 6 \text{ V} \cdot V_{act} [\text{m}^3/\text{h}] : V_{max} [\text{m}^3/\text{h}] \quad [3b]$$

Volume flows in [% V_{max}] can also be used instead of in [m^3/h].

The analogue voltage signal **AOut2** is available at output 2, terminal 4, **for improving the energy efficiency of the fan output**. Depending on the setting of the reference signal U, the efficiency is as follows:

$$0 - 10 \text{ V: } \text{Efficiency [\%]} = 100\% \cdot \text{AOut2 [V]} : 10 \text{ V} \quad [4]$$

$$2 - 10 \text{ V: } \text{Efficiency [\%]} = 100\% \cdot (\text{AOut2 [V]} - 2 \text{ V}) : 8 \text{ V} \quad [5]$$

$$2 - 8 \text{ V: } \text{Efficiency [\%]} = 100\% \cdot (\text{AOut2 [V]} - 2 \text{ V}) : 6 \text{ V} \quad [6]$$

Volume flow controllers should be operated so that they **reduce the volume flow slightly**. They should be opened as wide as possible. The smaller the resulting pressure drops are, the more energy efficient the ventilation and air conditioning system will be when in operation.

A low efficiency signal – efficiency → 0% – means that the volume flow controller is operating with a high pressure drop and is restricting the flow considerably. The system operating pressure could be less and the fan could be operating at a lower speed. The efficiency signal should ideally be high, **efficiency → 90%**.

The volume flow controller will then have an optimum operating pressure in terms of energy efficiency. However, up to 95% is advisable in order to ensure that sufficient air distribution and pressure stability is maintained in the system.

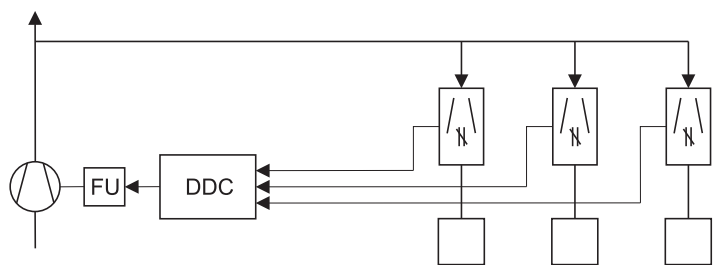

Fan control with efficiency optimisation

Example: In a DDC control system, the efficiency signals of all volume flow controllers are analysed and the speed of the fan adjusted accordingly until a controller shows a higher efficiency signal.

The **efficiency signal** takes the volume flow, pressure drop and damper blade position into account.

- 0 – 10 V output signals and the above formulas [1a], [1b] and [4] are used in constant mode and 4-point mode.
- If a controller receives a close/open signal in variable mode via the reference signal U or via an override, the output signals for the actual volume flow **AOut1** and for efficiency **AOut2** are 0 V or 10 V respectively; **close/open** appears on the display.

VRE1 volume flow controller

Stand-alone operation, Parallel operation and Master/Slave sequential operation, examples (1)

With **Stand-alone operation**, the volume flow controller is set to one of the possible operation modes. With **Parallel operation**, this affects two or more. The reference signals are always identical and applied electrically either individually or in parallel to terminal 5 or terminals 6 to 8. When connected in parallel, controllers operate independently of one another.

Reference volume flows **OVFmin**, **OVFmax**, **OVFmid1**, **OVFmid2** can be adjusted independently of one another, and according to the size and operation modes of the controller. If changes are made to one controller this does not affect the others.

With **Master/Slave sequential operation**, the actual volume flow V_{act} of one controller controls the reference volume flow V_{ref} of another. The output signal **AOut1** at terminal 3 of the controlling controller (Master) is fed as reference signal **AIn** to terminal 5 of the controller being controlled (Slave). If “Variable 0 – 10 V”, “Variable 2 – 10 V” or “Variable 2 – 8 V” is set at the Master, the same modes must be set at the Slave. If “Constant” or “4-point” is set at the Master, “Variable 0 – 10 V” must be set at the Slave. In this case it is advisable to set $OVFmin = 0\% V_{max}$ and $OVFmax = 100\% V_{max}$ at the Slave; However, $OVFmax \geq 30\% V_{max}$ can also be set.

Example 1:

Stand-alone operation of volume flow controller and Parallel operation with identical volume flow.

If the operation mode 2 – 8 V is set at the controllers, the control range is controlled with $U = 2$ to 8 V as reference signal at **AIn**. With $OVFmin = 35\% V_{max}$ and $OVFmax = 70\% V_{max}$, a reference volume flow is specified according to page 4, formula [3]. With $U = 2$ V as reference signal at **AIn**, it is

$$V_{ref} = 35\% + (70\% - 35\%) \cdot (2\text{ V} - 2\text{ V}) : 6\text{ V} = 35\% V_{max}$$

When $U = 5.2$ V is selected as reference signal between 2 and 8 V:

$$V_{ref} = 35\% + (70\% - 35\%) \cdot (5.2\text{ V} - 2\text{ V}) : 6\text{ V} = 54\% V_{max}$$

With $U = 8$ V as the largest reference signal:

$$V_{ref} = 35\% + (70\% - 35\%) \cdot (8\text{ V} - 2\text{ V}) : 6\text{ V} = 70\% V_{max}$$

Example 2:

Parallel operation of volume flow controllers with constant volume flow differential

If the operation mode 2 – 8 V is set at the controllers, the control range is controlled with $U = 2$ to 8 V as reference signal at **AIn**.

With $OVFmin = 35\% V_{max}$ and $OVFmax = 70\% V_{max}$ at the first controller, a reference volume flow is then specified according to page 4, formula [3]. With $U = 5.2$ V, for example, this is a possible reference signal between 2 and 8 V:

$$V_{ref} = 35\% + (70\% - 35\%) \cdot (5.2\text{ V} - 2\text{ V}) : 6\text{ V} = 54\% V_{max}$$

If a constant volume flow which is always 12% lower is to be achieved at the second controller, the settings $OVFmin = 23\% V_{max}$ and $OVFmax = 58\% V_{max}$ must be specified at this one. With $U = 5.2$ V,

$$V_{ref} = 23\% + (58\% - 23\%) \cdot (5.2\text{ V} - 2\text{ V}) : 6\text{ V} = 42\% V_{max}$$

Example 3:

Parallel operation of volume flow controllers with proportionally-equal volume flow differential

If the operation mode 0 – 10 V is set at the controllers, the control range is controlled with $U = 0$ to 10 V as reference signal at **AIn**.

With $OVFmin = 0\% V_{max}$ and $OVFmax = 100\% V_{max}$ at the first controller, a reference volume flow is then specified according to page 4, formula [1]. With $U = 4$ V, for example, this is a possible reference signal between 0 and 10 V:

$$V_{ref} = 0\% + (100\% - 0\%) \cdot 4\text{ V} : 10\text{ V} = 40\% V_{max}$$

If a constant volume flow which is always 40% lower is to be achieved at the second controller, the settings $OVFmin = 0\% V_{max}$ and $OVFmax = 60\% V_{max}$ must be specified at this one. With $U = 4$ V on the other hand

$$V_{ref} = 0\% + (60\% - 0\%) \cdot 4\text{ V} : 10\text{ V} = 24\% V_{max}$$

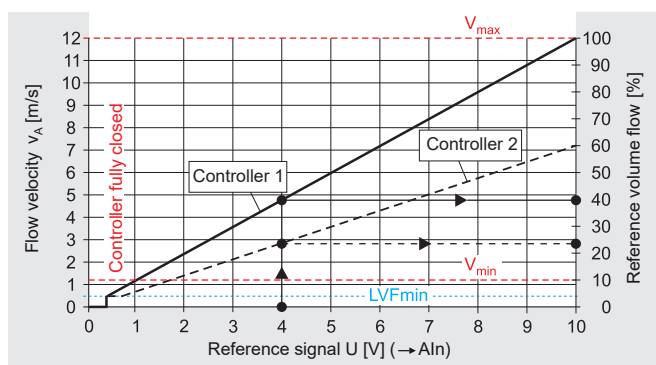
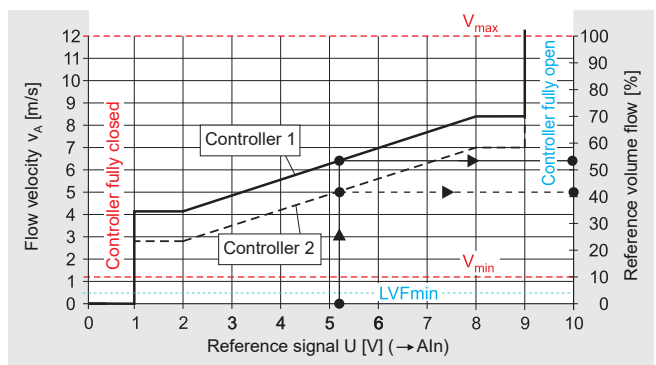
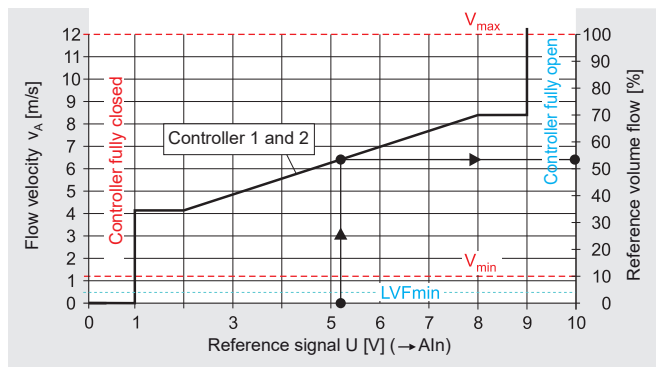

VRE1 volume flow controller

Stand-alone operation, Parallel operation and Master/Slave sequential operation, examples (2)

Example 4: Master/Slave sequential operation to volume flow controller with identical volume flow

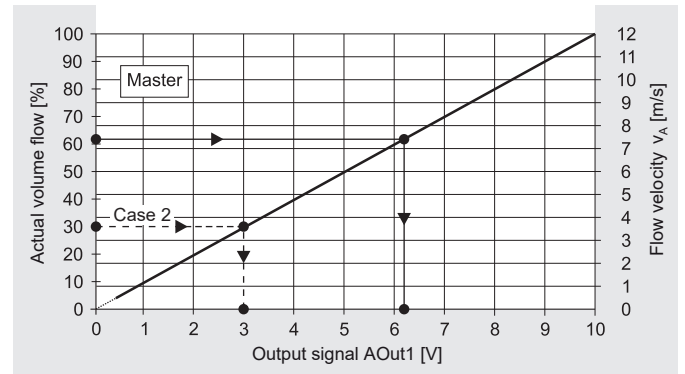
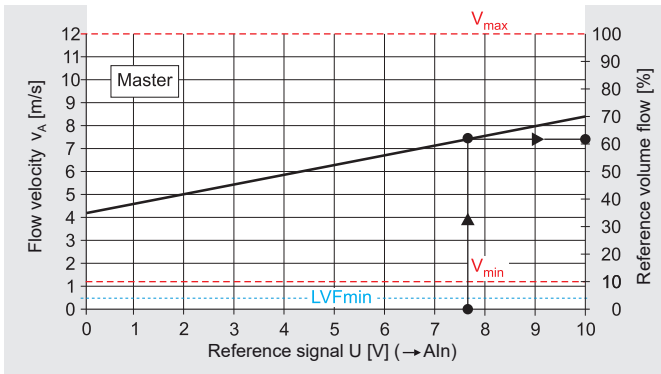

The operation modes 0 – 10 V are set at the **Master** and **Slave**. The Master is then controlled with $U = 0$ to 10 V. For $OVF_{min} = 35\% V_{max}$ and $OVF_{max} = 70\% V_{max}$ as well as with e.g. $U = 7.6$ V according to page 4, formula [1]:

$$V_{ref} = 35\% + (70\% - 35\%) \cdot 7.6 \text{ V} : 10 \text{ V} = 62\% V_{max}$$

With $V_{act} = V_{ref}$, the **output signal** according to page 5, formula [1b] is:
 $AOut1 = 10 \text{ V} \cdot 62\% : 100\% = 6.2 \text{ V}$

This voltage is specified by the Master as reference signal to the Slave at **AIn** where $OVF_{max} = 30$ to 100% V_{max} can be variably adjusted.

If $OVF_{max} = 100\% V_{max}$ is set at the **Slave**, according to page 4, formula [1]:
 $V_{ref} = 0\% + (100\% - 0\%) \cdot 6.2 \text{ V} : 10 \text{ V} = 62\% V_{max}$

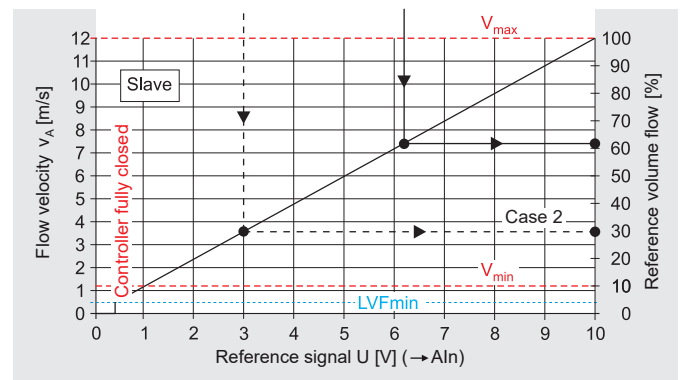

If the actual volume flow at the Master does not reach the reference volume flow, the Slave follows the actual volume flow! ⇒ see example 2!

Example 5: Master/Slave sequential operation for volume flow controller with identical proportionally-equal volume flow

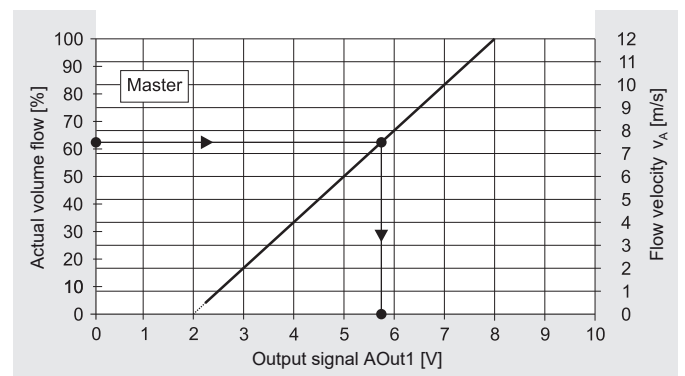
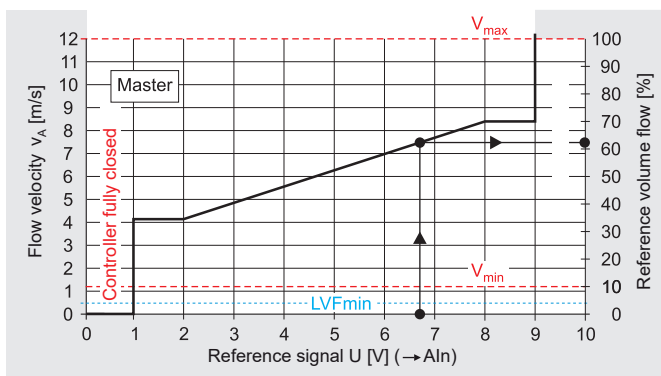

The operation modes 2 – 8 V are set at the **Master** and **Slave**. The Master is set to $OVF_{min} = 35\% V_{max}$ and $OVF_{max} = 70\% V_{max}$ and activated with $U = 2$ to 8 V. When $U = 6.7$ V, according to page 4, formula [3]:
 $V_{ref} = 35\% + (70\% - 35\%) \cdot (6.7 \text{ V} - 2 \text{ V}) : 6 \text{ V} = 62\% V_{max}$

When $V_{act} = V_{ref}$, the corresponding **output signal** according to page 5, formula [3b], is:
 $AOut1 = 2 \text{ V} + 6 \text{ V} \cdot 62\% : 100\% = 5.7 \text{ V}$

This voltage is specified by the Master as reference signal **AIn** to the Slaves. $OVF_{max} = 30$ to 100% V_{max} can be variably adjusted at these.

If $OVF_{max} = 100\% V_{max}$ is set at **Slave 1**, according to page 4, formula [3]:

$$V_{ref} = 0\% + (100\% - 0\%) \cdot (5.7 \text{ V} - 2 \text{ V}) : 6 \text{ V} = 62\% V_{max}$$

If $OVF_{max} = 60\% V_{max}$ is set at **Slave 2**, according to page 4, formula [3]:

$$V_{ref} = 0\% + (60\% - 0\%) \cdot (5.7 \text{ V} - 2 \text{ V}) : 6 \text{ V} = 37\% V_{max}$$

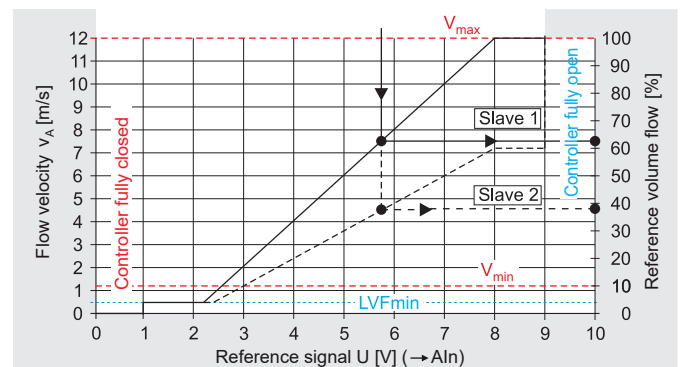

Nomenclature ⇒ see page 4

VRE1 volume flow controller

Sound power level inside the connecting duct – flow noise – (1)

Size DN 100

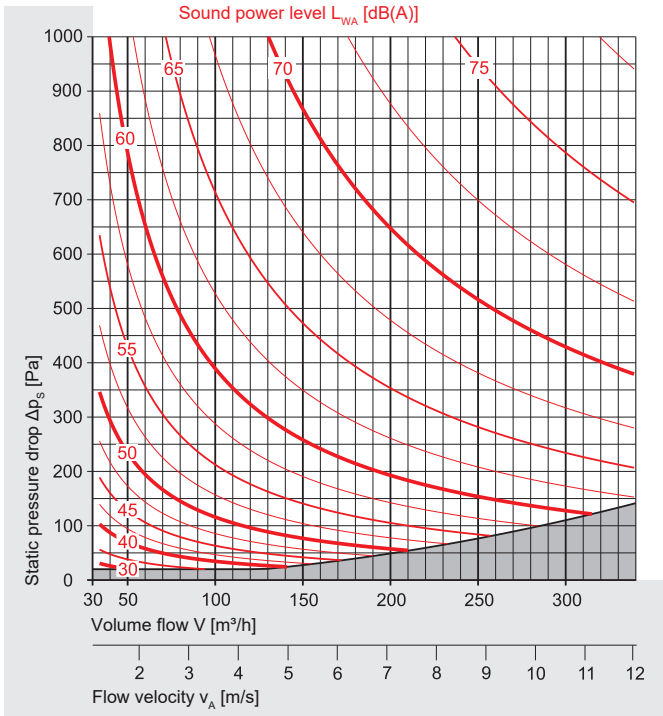

Size DN 125

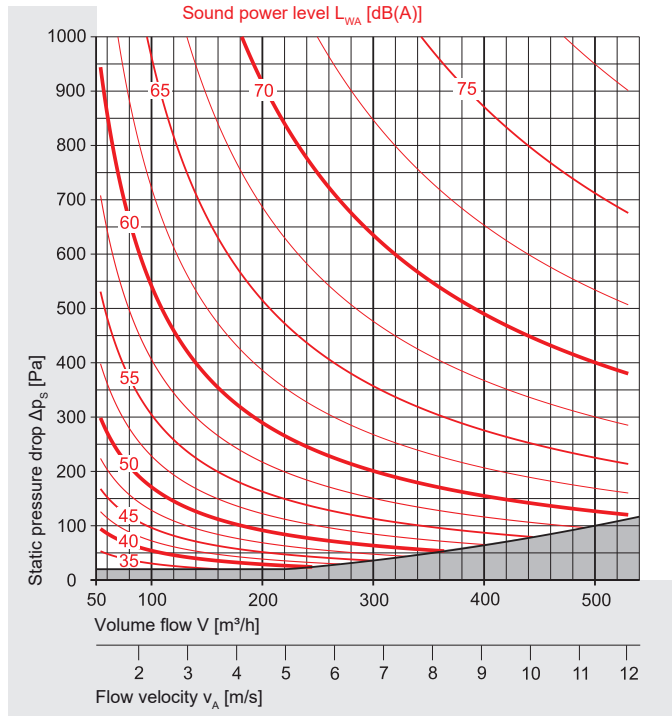

Size DN 160

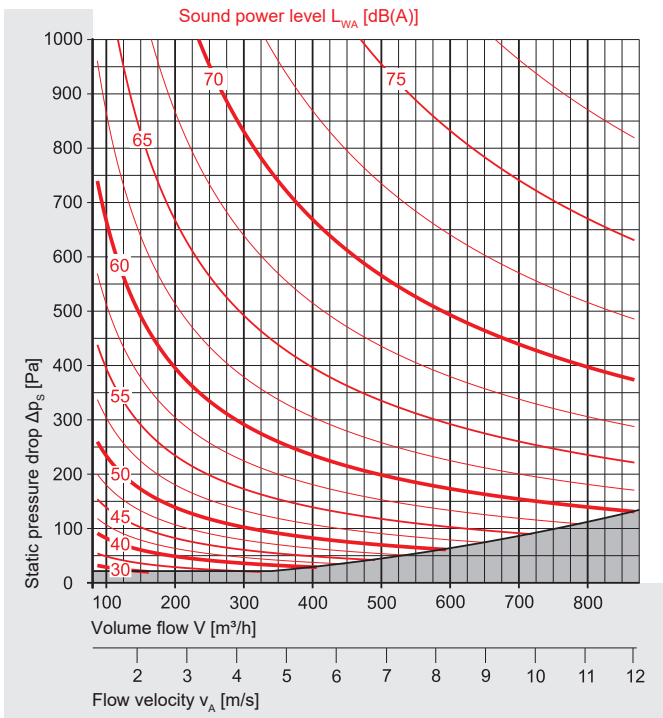

Size DN 200

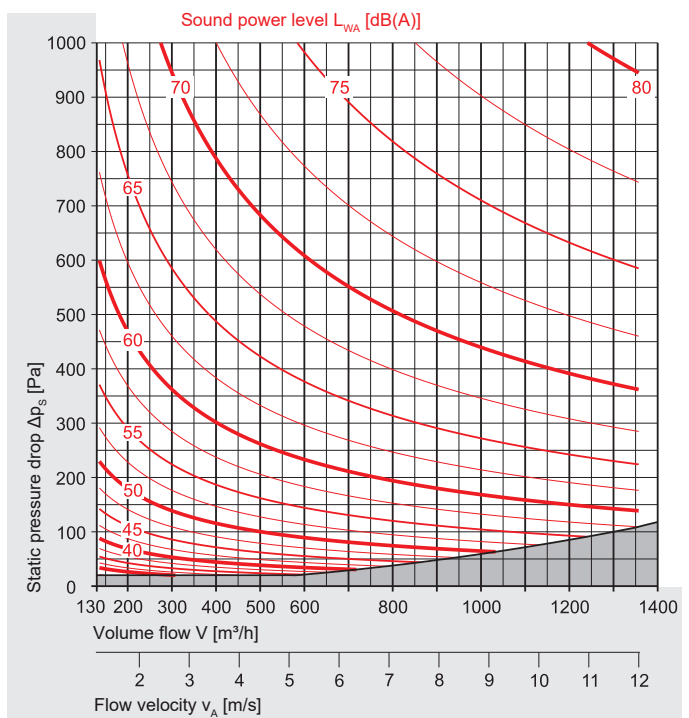

Observe limitations shaded in grey.

Nomenclature \Rightarrow see page 4

VRE1 volume flow controller

Sound power level inside the connecting duct – flow noise – (2)

Size DN 250

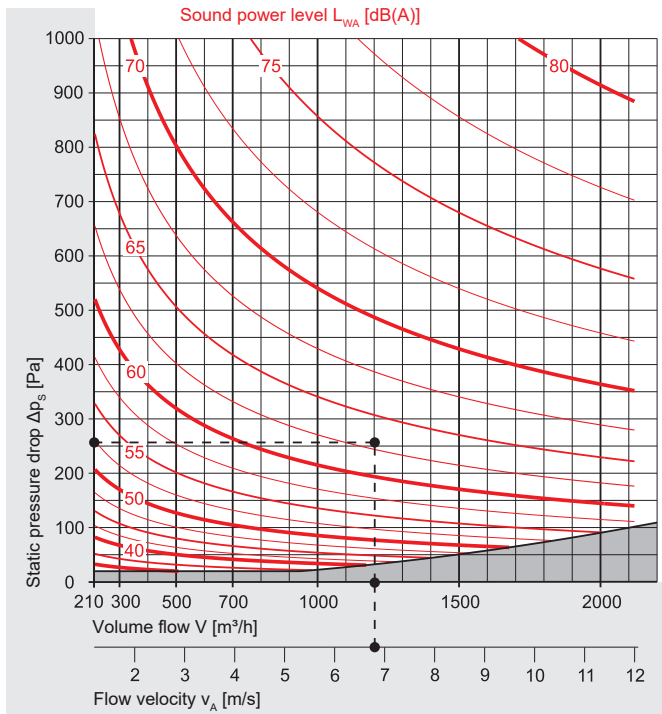

Size DN 315

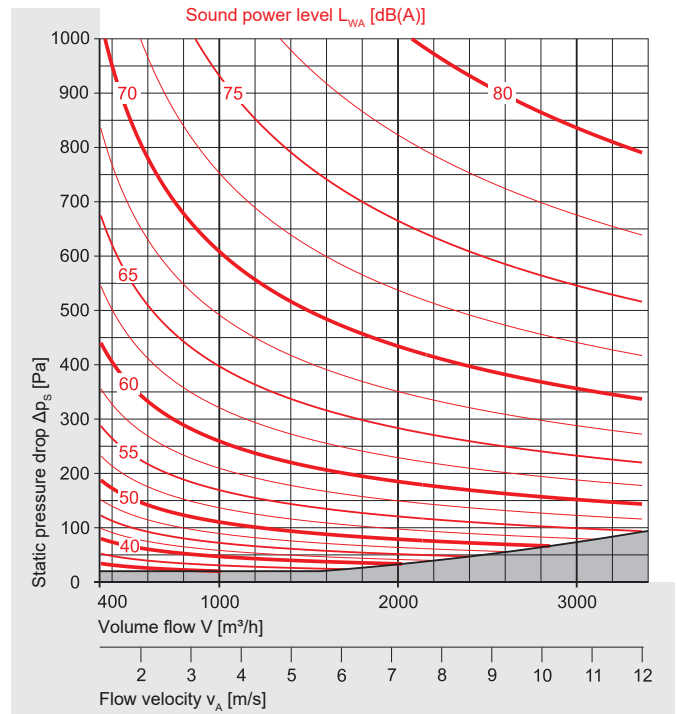

Size DN 400

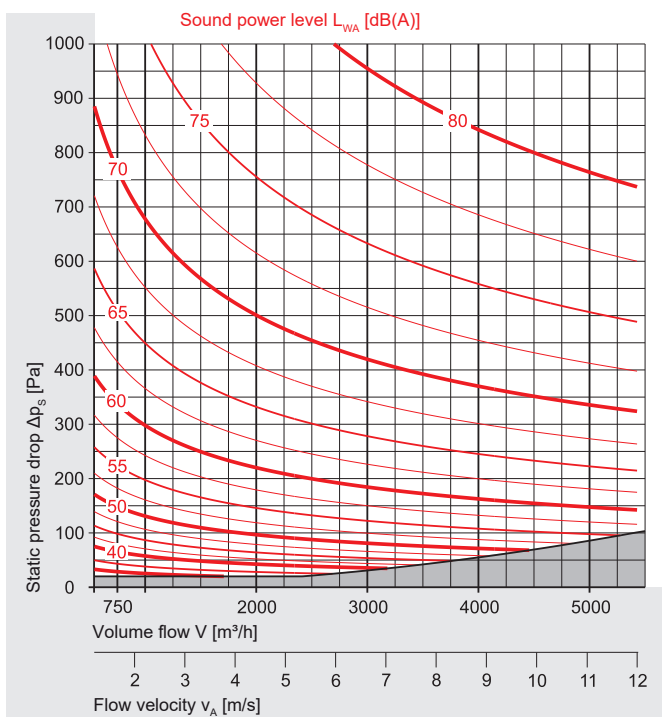

Example:

Specified: Size	DN 250
Volume flow	$V = 1200 \text{ m}^3/\text{h}$
Flow velocity	$v_A = 6.8 \text{ m/s}$
Static pressure drop	$\Delta p_s = 260 \text{ Pa}$
Result: Flow noise	
Sound power level	$L_{WA} = 63 \text{ dB(A)}$

- In the nomograms, the sound power level inside the connecting duct is calculated as an A-weighted overall level L_{WA} . Corresponding octave sound power levels L_{W-Oct} are obtained from the Wildeboer dimensioning software for every size and all operating points; likewise for the design with additional SRC duct silencers.
- With SRC duct silencers, the sound power levels L_{WA} can be reduced by up to 31 dB.

Important: The sound levels indicated in the nomograms are **sound power levels!** The values represent the sound energy introduced into the duct system. They should be applied for acoustic calculations, e.g. when adding sound attenuators.

In other documents, **sound pressure levels** L_p or L_{pA} are **frequently specified** instead of sound power levels. They contain standardized attenuations of up to 18 dB. This distinction must be observed when comparing numeric values. Furthermore, the extent of these attenuations only becomes clear once the ducts, baffles, branches and spaces have actually been connected.

Further example \Rightarrow see page 11

VRE1 volume flow controller

Sound power level outside the connecting duct – radiated noise – (1)

Size DN 100

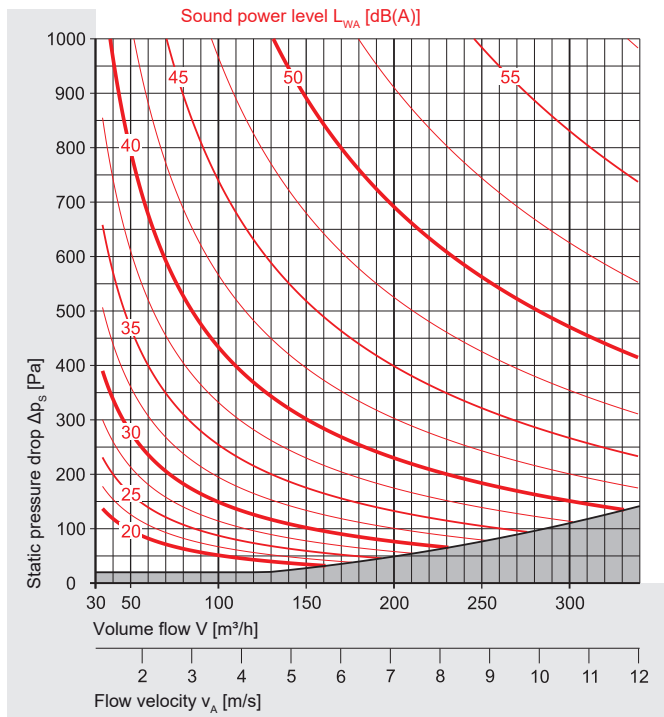

Size DN 125

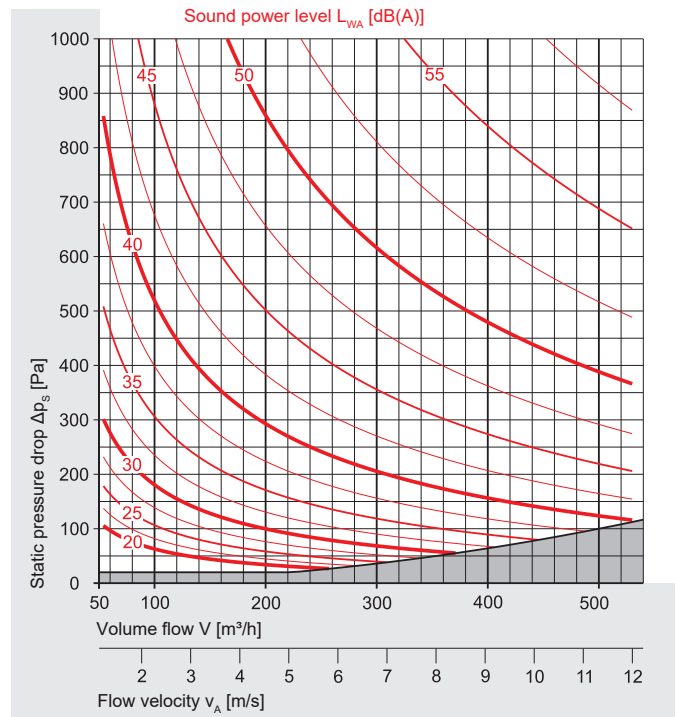

Size DN 160

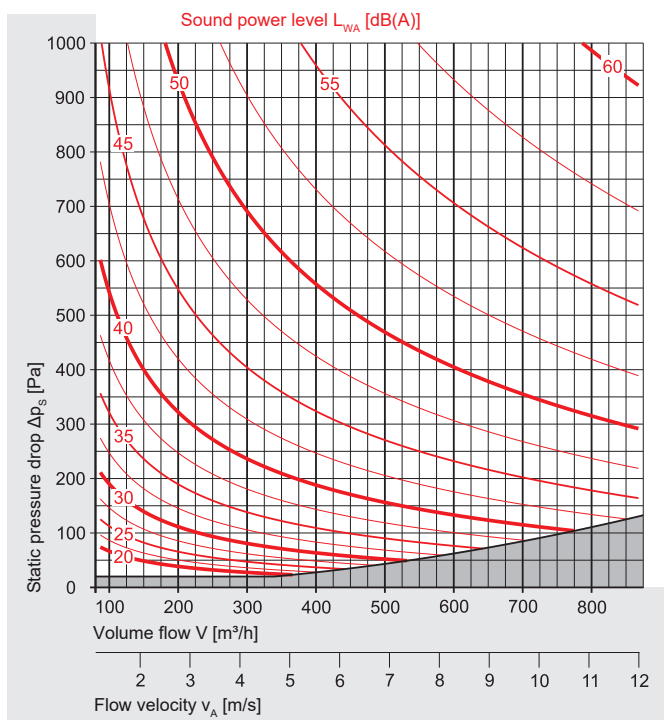

Size DN 200

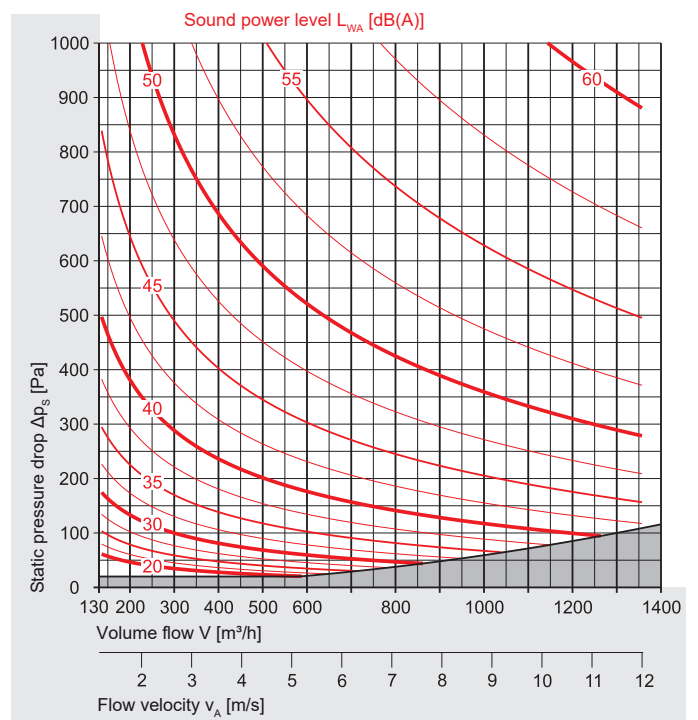

Observe limitations shaded in grey.

Nomenclature \Rightarrow see page 4

VRE1 volume flow controller

Sound power level outside the connecting duct – radiated noise – (2)

Size DN 250

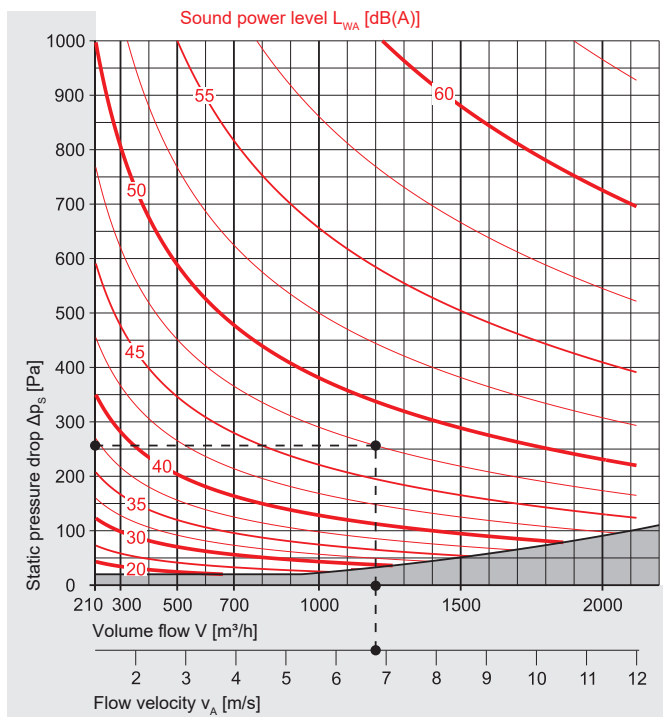

Size DN 315

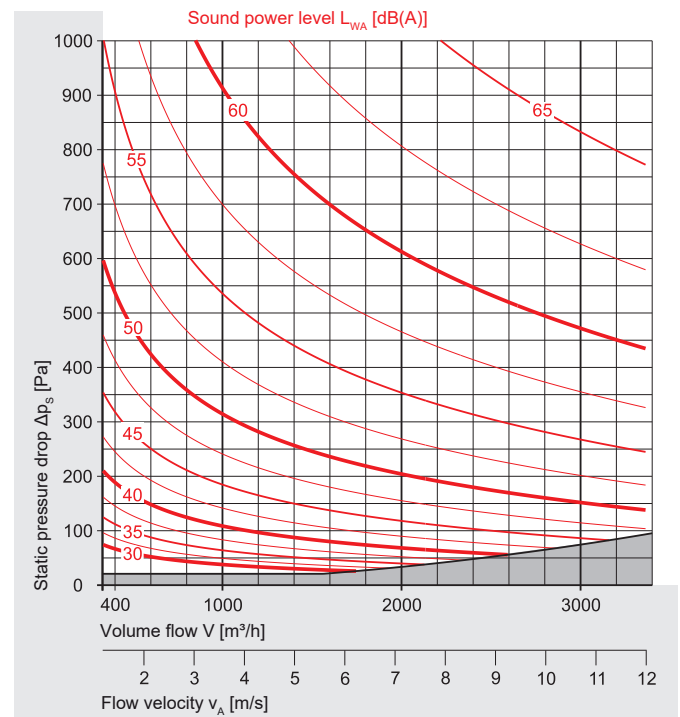

Size DN 400

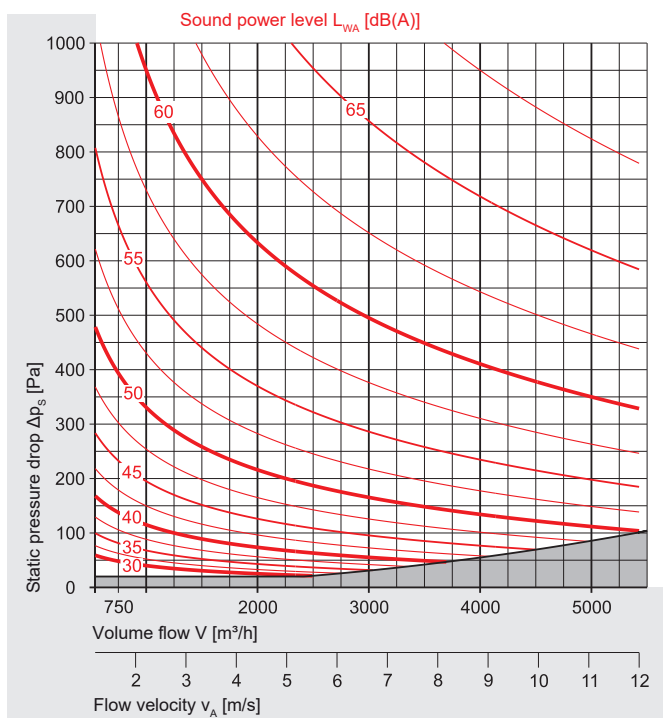

Example

Specified:	Size	DN 250
	Volume flow	$V = 1200 \text{ m}^3/\text{h}$
	Flow velocity	$v_A = 6.8 \text{ m/s}$
	Static pressure drop	$\Delta p_s = 260 \text{ Pa}$
Result:	Flow noise \Rightarrow see example on page 9	
	Sound power level	$L_{WA} = 63 \text{ dB(A)}$
Result:	Radiated noise	
	Sound power level ¹⁾	$L_{WA} = 47.5 \text{ dB(A)}$

1) The average **sound pressure level in the room** with the following equipment is

- **26 dB less with acoustic insulation**
- **8 dB less without acoustic insulation**

than the sound power level L_{WA} specified in the nomograms. However, the sound attenuation of the acoustic insulation specified only applies if connected ventilation ducts are also insulated (isolated) accordingly.

The sound pressure level can be further reduced by on site acoustic insulation measures (suspended ceilings, high room attenuation).

Further example \Rightarrow see page 9

VRE1 volume flow controller

Electrical connections / terminal assignment

Electrical connections

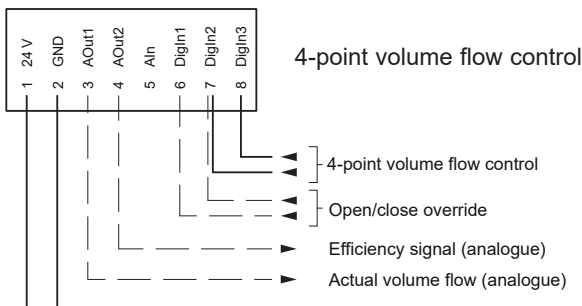
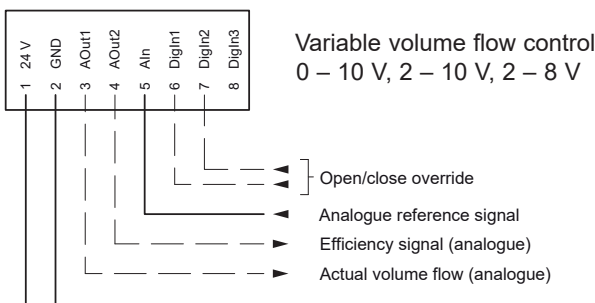
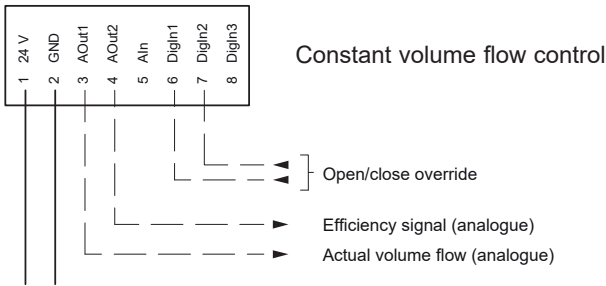

— : Connections are absolutely required.
 - - - : Connections are optional.

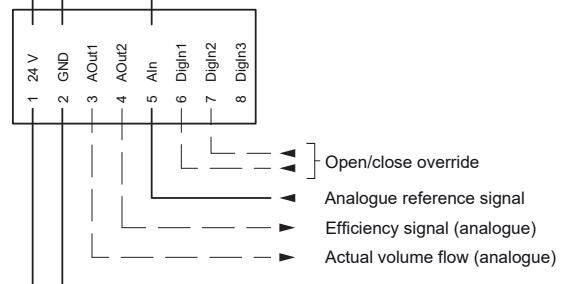
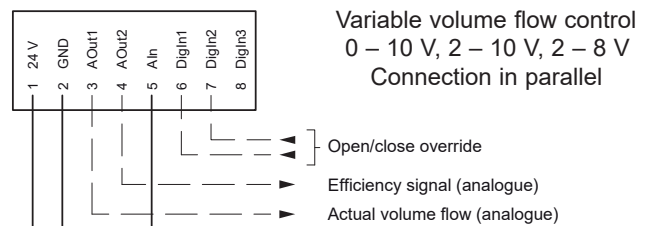
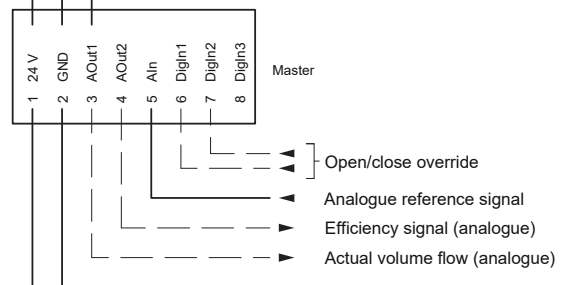
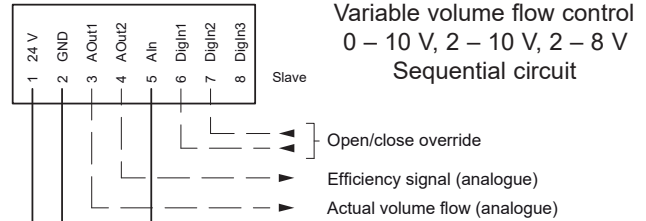

Terminal assignment of connection plug

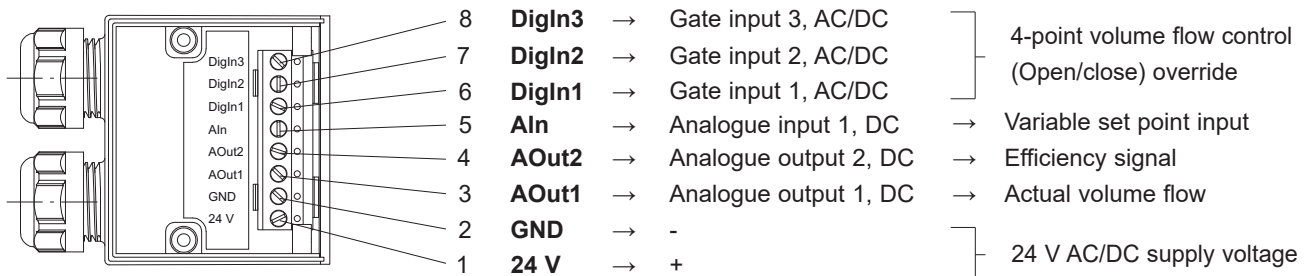

- Accuracy of analogue inputs and outputs: $\pm 1\%$ from end value
- All inputs and outputs are not electrically isolated.
- DigIn: 115 μA @ 24 V DC (HIGH > 19.1 V DC, LOW < 12.5 V DC)
540 μA @ 24 V DC (HIGH > 13.8 V DC, LOW < 9.2 V DC)

- AIn: 50 μA @ 10 V DC (delay: up to 15 s)
- AOut: max. 1 mA @ 10 V DC (load > 10 k Ω ; short-circuit proof)

VRE1 volume flow controller

Installation instructions

- VRE1 volume flow controllers are designed for ventilation and air conditioning systems. Suitable air purity is a prerequisite for operation.
- VRE1 volume flow controllers are adjusted for the entire controllable volume flow range from V_{min} to V_{max} and achieve the specified control accuracy in this range. Larger deviations can occur with low volume flows, especially with small sizes.
- For the VRE1 volume flow controller to work efficiently, the flows must be extensively undisrupted. The straight inlet and outlet sections shown as examples must be adhered to as minimum requirement downstream of flow disruption points (e.g. fire dampers, reductions, bends, branches); longer inlet sections may be required where several disruption points occur consecutively. Otherwise significant nonconformities must be anticipated.
- VRE1 volume flow controllers and SRC duct silencers are delivered individually. Assembly on site.
- VRE1 volume flow controllers are opened to a damper blade position of roughly 45° at the factory and are supplied with a standard setting or customer-specific presetting.
⇒ see page 14.

Changes can be made on site at the:

- Volume flow controller with the actuator M1 with the adjustment buttons and plain text display in the illuminated display.
- PC with software supplied via the RS232 interface.

Can be reset to the delivery condition.

- Once installed in the circular ventilation duct, the VRE1 volume flow controller identifies its installation position automatically and optimises its control accuracy accordingly. If the installation is subsequently changed, this optimisation can be carried out once again by switching the power supply off and back on.

If no system operating pressure is present, the device is opened to a minimum damper blade setting angle which depends on the set point. Once the necessary minimum pressure loss or volume flow has been detected, the VRE1 volume flow controller goes into operation.

⇒ for limitations see pages 8 and 11

- To ensure lasting functionality and leak tightness, the devices must be installed in circular ventilation ducts free of tension. The assembly instructions are enclosed with the VRE1 volume flow controllers.
- The actuator is overload-proof. In the event of a power failure, it remains in the current position. The settings are retained.
- Cables should be routed separately to power and control lines, or be a sufficient distance from them. Whenever possible, they should have a radial form and be routed over the shortest possible distance to avoid loops.
- The signal inputs and outputs of the VRE1 volume flow controllers are not potential-free. The local potential relationships must be checked. Measures to prevent corrupting or harmful equalising currents may be required.

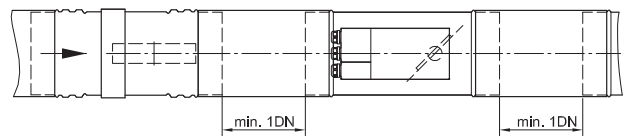

Figure 1: Installation downstream of disruption point, e.g. fire damper

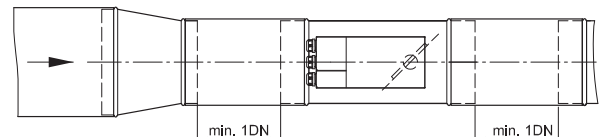

Figure 2: Installation downstream of disruption point, e.g. reduction

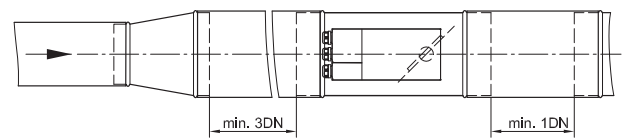

Figure 3: Installation downstream of disruption point, e.g. widenings

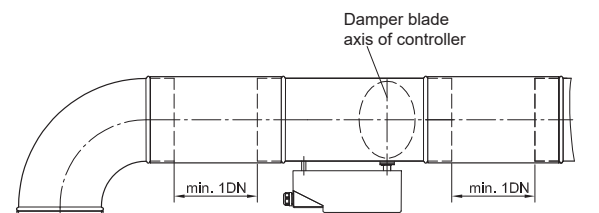

Figure 4: Installation downstream of disruption point, e.g. bend
Observe orientation of damper blade axis!

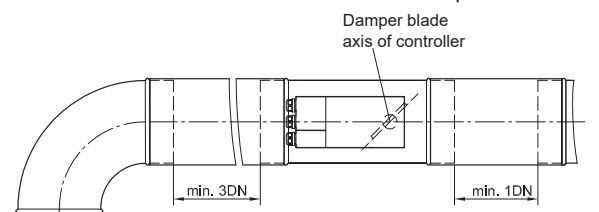

Figure 5: Installation downstream of disruption point, e.g. bend
Observe orientation of damper blade axis!

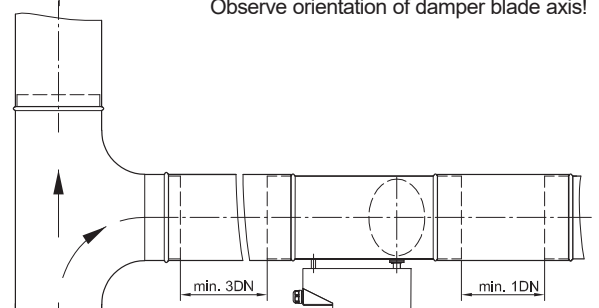

Figure 6: Installation downstream of disruption point, e.g. T-pieces

VRE1 volume flow controller

Order data

DN size 100 / 125 / 160 / 200 / 250 / 315 / 400 ⇒ see pages 2 and 3	VRE1 - - - - -	with duct silencer (attachment on site) SRC 600 (up to DN 315) SRC 900 ⇒ see pages 2 and 3
Drives		
- 24 V AC/DC actuator - standard - ⇒ see pages 2 to 4	M1	
- 24 V AC/DC actuator M2 without display, LEDs and adjustment buttons. Settings of PC with RS232 interface.		
Option: Lip seal with two lip seals ⇒ see pages 2 and 3	LD	
Option: Acoustic insulation with acoustic insulation ⇒ see pages 2 and 3	DS	
Option: Presets¹⁾		
- Operation mode		
- Constant	KO	
- 4-point	4P	
- Variable, 0 V – 10 V - standard -	01	
- Variable, < 2 V, 2 V – 10 V	21	
- Variable, < 2 V, 2 V – 8 V, > 8 V	28	
- Reference volume flow in m³/h		
- Constant reference volume flow OVFconst = Standard: 45% V _{max} for operation mode KO		Entries depend on operation mode! Observe the following limit values for this in Operation mode Constant: $V_{\min} \leq \text{OVFconst} \leq V_{\max}$ Variable: $0 \text{ m}^3/\text{h} \text{ or } 0.4 \cdot V_{\min} \leq \text{OVFmin} < \text{OVFmax}$ and $30\% V_{\max} \leq \text{OVFmax} \leq V_{\max}$ 4-point: $V_{\min} \leq \text{OVFmin} < \text{OVFmid1} < \text{OVFmid2} < \text{OVFmax} \leq V_{\max}$
- Minimum reference volume flow OVFmin = Standard: 30% V _{max} for operation mode 4P, 01, 21, 28		
- 1st average reference volume flow OVFmid1 = Standard: 45% V _{max} for operation mode 4P		
2nd average reference volume flow OVFmid2 = Standard: 60% V _{max} for operation mode 4P		
- Maximum reference volume flow OVFmax = Standard: 75% V _{max} for operation mode 4P, 01, 21, 28		
⇒ see page 4		

¹⁾ Controllers are preset as "standard" at the factory. Customer-specific settings for the operation mode and reference volume flow are possible as **factory pre-settings**.

Download from www.wildeboer.de:

- PC software for making on site changes to the pre-settings
- Hygiene certificate
- Hygiene instructions for disinfection

VRE1 volume flow controller

Specification text

Maintenance-free, electronic volume flow controller for variable and constant volume flows. Round design for installation in circular ventilation ducts for supply and exhaust air ventilation and air conditioning systems. Duct casing and centrally supported damper blade made of galvanised sheet steel, stainless steel bearing shafts in special bearing bushes. With peripheral seal on the damper blade to shut off the circular ventilation duct.

Measuring device integrated into the damper blade. High degree of control accuracy in a total volume flow range of 1:10. The volume flow must be kept constant at variable pressures between 20 and 1000 Pa with a maximum deviation of $\pm 5\%$ to $\pm 15\%$.

Maintenance-free 24 V actuator with integrated electrical connection and strain relief. Constant, Variable or 4-point operation modes can be set via illuminated display with plain text display or using software via an RS232 interface. LED status displays for indication of controller operation statuses. Adjustable operation modes 0 - 10 V, 2 - 10 V and 2 - 8 V for variable operation. Higher-level override for opening and closing the damper blade. Analogue output signals for the actual volume flow and for efficiency in order to optimise the fan output. Equipment for parallel and sequential operation of several volume flow controllers.

Leak tightness class C for the casing and leak tightness class 3 or 4 for the damper blade, each according to DIN EN 1751. Certificate of conformity as proof of compliance with the hygiene requirements in accordance with VDI 6022-1, VDI 3803-1, DIN 1946-4, DIN EN 13779, SWKI VA104-01, SWKI 99-3, ÖNORM H6020 and ÖNORM H6021. With Environmental Product Declaration certificate according to ISO 14025 and EN 15804.

With acoustic insulation, with lip seals.

.....	units		
	Volume flow:	from m ³ /h
		to m ³ /h
	Pressure drop:	 Pa
	Maximum sound power level		
	Flow noise	 dB (A)
	including SRC duct silencer		
	Radiated noise	 dB (A)
	Manufacturer:		WILDEBOER®
	Type:		VRE1
	Size:		DN
	Complete with attachments	deliver:
		install:
.....	units duct silencer SRC 600 / 900		
		deliver:
		install:

Select texts not highlighted in bold as required!

Fire protection

Operational reliability and safety



Energy efficiency

Wildeboer-Net

Communication system Wildeboer-Net

BS2-VR-01 volume flow and pressure controller module

Network your fire protection and air distribution and significantly minimise the cost of planning, installation and function testing of fire dampers. The communication system Wildeboer-Net lays all the groundwork for you.

The BS2-VR-01 volume flow and pressure controller module extends the scope of functions to include new options for automatic control of the volumetric flow rates. Control takes place in accordance with thermal and material loads or to adjust the volume flows in accordance with time.



Additional protection against cold smoke transfer in accordance with VDI Guideline 6010 by closing existing electronic volume flow and pressure controllers via programmable tripping groups.



Energy saving by reducing the mean outdoor air volume flow rate using requirement-based air volume flow rate control via parametrised calendar and sequence controls.

Don't miss out on these benefits. Further information can be found in the user manual of the BS2 communication system Wildeboer-Net. If you need advice, please do not hesitate to contact us.

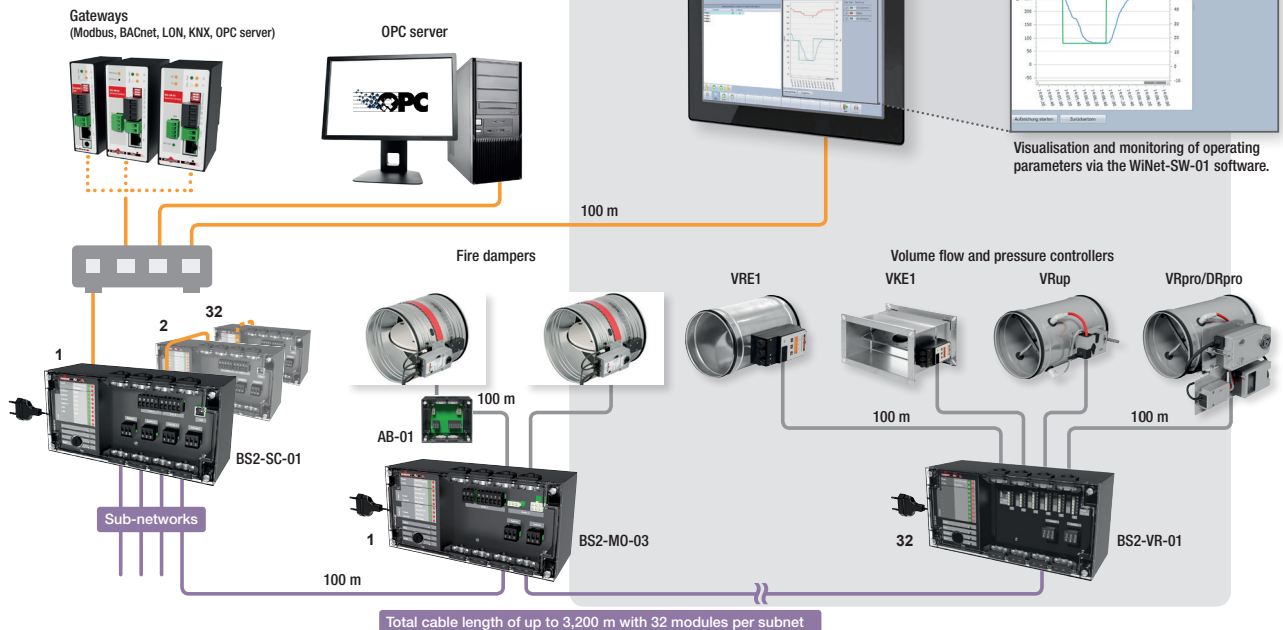

© 2011 2019 WILDEBOER BAUTEILE GMBH D26826 WEENER

Wildeboer Bauteile GmbH

Marker Weg 11 | 26826 Weener | +49 4951 950-27120

info@wildeboer.de | www.wildeboer.de

Watch explanatory video on YouTube
wildeboer.de/youtube

