



AIR DISTRIBUTION

Pressure controller DKpro



Contents

1	Product overview	3
2	Product features	4
3	Product description	6
3.1	Accuracy.....	7
3.2	Function of pressure control.....	7
3.3	Function of operating modes.....	8
3.3.1	Stand-alone operation, parallel operation and master-slave sequential operation – examples.....	10
3.4	Applications.....	11
3.5	Accessories.....	12
3.5.1	Acoustic insulation with sheet metal jacket.....	12
3.5.2	SKE-V sound attenuator.....	13
3.5.3	Link.10.....	13
3.5.4	Volumetric flow rate measuring device.....	13
3.5.5	Pressure tapping set.....	13
3.6	Installation.....	14
3.7	Installation information / clearances to obstructions.....	15
4	Technical data	16
4.1	Weights.....	16
4.2	Dimensions.....	18
4.2.1	SKE-V sound attenuator.....	18
4.3	Sound power level inside the ventilation duct – flow noise.....	19
4.4	Sound power level outside the ventilation duct – radiated noise.....	20
4.5	Sound power level inside / outside the ventilation duct – examples.....	21
5	Electrical connection	22
6	Specification text	24
7	Wildeboer makes it easy	25
7.1	Wildeboer Connect.....	25
7.2	WiDim dimensioning software.....	25
7.3	Documents online.....	25

1 Product overview

DKpro pressure controllers regulate the pressure in ventilation ducts or rooms using a controller with an integrated sensor and an actuator. The controllers have LED status indicators and a service port, while the actuators have a manual adjustment function. With the dynamic sensor, a small amount of air flows through the sensor. It is proportional to the static pressure in the ventilation duct or the room. There is a thermal detection in a measuring chamber. There is no flow through static sensors. The static pressure present at the pressure tapping point downstream of the DKpro pressure controller, or the static pressure present in a room, is directed into a diaphragm measuring chamber and detected inductively. In addition to a selection of controllers and actuators, optional acoustic insulation is available.



- Can be set on site
- Position-independent installation
- Maintenance-free design
- Sizes W x H: 200 x 100 ... 1000 x 1000 mm
- Lengths L: 250 mm
- Leak tightness class: Casing: ATC 3 (formerly C) in accordance with DIN EN 1751
Damper blade: Class 4 in accordance with DIN EN 1751
- Maximum differential pressure: 1000 Pa
- Differential pressure control range: 5 ... 1000 Pa
- Differential pressure sensor: Dynamic up to 500 Pa or static up to 75 / 600 Pa
- Volumetric flow rate control range: 72 ... 36000 m³/h*
- Flow velocities: 1.0 ... 10 m/s
- Voltage supply: 24 V AC/DC, -10 % +20 %
- Communication: Analogue, bus-compatible (MP-Bus**, Modbus**, BACnet**)
- Actuators: Standard speed, high speed or with spring return for emergency operation
- Operating temperature: 0 ... +50 °C
- Protection rating: IP42 in accordance with DIN EN 60529
- Hygiene certificate: W-408912-25-JRoll, issued by: Ruhr District Institute of Hygiene
- Environment Product Declaration: EPD-WIL-20230373-ICA1-DE, issued by: Institut Bauen und Umwelt e. V.
- Operating modes: constant, variable (0 ... 10 V, 2 ... 10 V, adjustable), overrides, parallel operation and sequential circuits possible
- Options
 - Factory presets
 - Acoustic insulation with sheet metal jacket
 - SKE-V sound attenuator
 - Pressure tapping set
 - Volumetric flow rate measuring device, dynamic or static

* Specifications depending on size

** Trademark of a third party

2 Product features

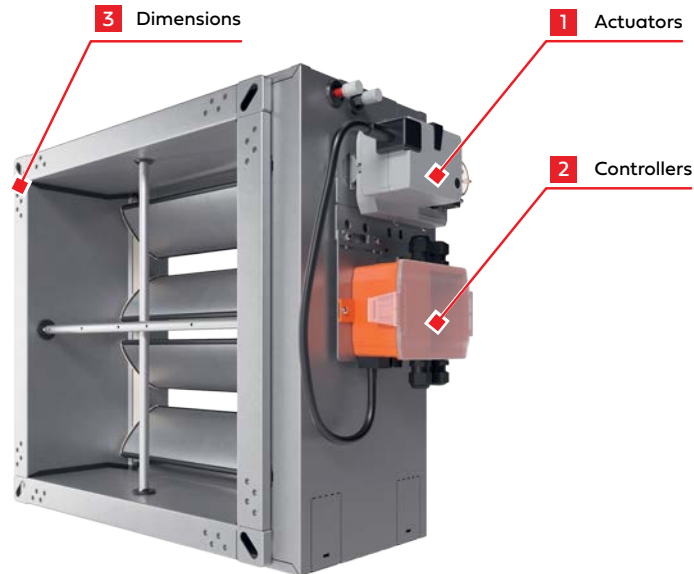

1 Actuators



Example illustration

Various actuators, differentiated by run mode / runtime:

Standard speed

- 120 s

High speed

- 4 s / 7 s

Spring return

- 120 s, 20 s spring

2 Controller



Example illustration

Different controllers, differentiated by sensor and measuring method:

static

- Diaphragm measuring method

dynamic

- Thermal measurement method

3 Dimensions

Width W [mm]	Height H [mm]	Inflow cross section A_A [m ²]	Min. ... Max. volumetric flow rate \dot{V} [m ³ /h]
200	100	0.020	72 ... 720
	200	0.040	144 ... 1440
300	100	0.030	108 ... 1080
	200	0.060	216 ... 2160
	300	0.090	324 ... 3240
400	100	0.040	144 ... 1440
	200	0.080	288 ... 2880
	300	0.120	432 ... 4320
	400	0.160	576 ... 5760
500	100	0.050	180 ... 1800
	200	0.100	360 ... 3600
	300	0.150	540 ... 5400
	400	0.200	720 ... 7200
	500	0.250	900 ... 9000

Product features

DKpro pressure controller

Width W [mm]	Height H [mm]	Inflow cross section A_A [m ²]	Min. ... Max. volumetric flow rate \dot{V} [m ³ /h]
600	100	0.060	216 ... 2160
	200	0.120	432 ... 4320
	300	0.180	648 ... 6480
	400	0.240	864 ... 8640
	500	0.300	1080 ... 10800
	600	0.360	1296 ... 12960
700	200	0.140	504 ... 5040
	300	0.210	7560 ... 75600
	400	0.280	1008 ... 10080
	500	0.350	1260 ... 12600
800	200	0.160	576 ... 5760
	300	0.240	864 ... 8640
	400	0.320	1152 ... 11520
	500	0.400	1440 ... 14400
	600	0.480	1728 ... 17280
	800	0.640	2304 ... 23040
900	300	0.270	972 ... 9720
	400	0.360	1296 ... 12960
	500	0.450	1620 ... 16200
1000	300	0.300	1080 ... 10800
	400	0.400	1440 ... 14400
	500	0.500	1800 ... 18000
	600	0.600	2160 ... 21600
	800	0.800	2800 ... 28000
	1000	1.000	3600 ... 36000

4 Accessories



Acoustic insulation with sheet metal casing to reduce the external sound radiation (radiated noise).
Optional accessories, pre-assembled in the factory



Link.10 setting and diagnostics tool for convenient configuration, commissioning and fault diagnosis.
Optional accessories

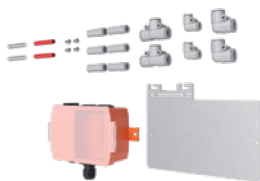

Volumetric flow rate measuring device for measuring and displaying the actual volumetric flow rate and for subsequent controls.
Optional accessories for on-site installation



Pressure tapping set for detecting the static pressure in the ventilation duct upstream and downstream of the pressure controller.
Optional accessories for on-site installation



SKE-V sound attenuator for reducing flow noise in the connected ventilation duct.
Optional accessories for on-site installation



BS2-VR-01 volumetric flow rate and pressure controller module for functional upgrade as a result of integration into the Wildeboer-Net communication system.
Optional accessories



Some of the accessories depend on the size. For reliable selection and to determine the appropriate order data, the web application [Wildeboer Connect](#) is recommended ▶ [Wildeboer Connect](#).

Product description

DKpro pressure controller

3 Product description

DKpro pressure controllers are maintenance-free electronic controllers for constant and variable pressures in ventilation and air conditioning systems or corresponding rooms. They can be installed and operated in any installation position in ventilation ducts for supply and exhaust air.

The casing and control mechanism are made of galvanised sheet steel. The blades for volumetric flow rate control are centrally supported and equipped with a seal. The bearing axles are made of stainless steel and are guided in special plastic bearing bushes. The measuring cross is made of aluminium. The measuring cross is only required for the optional volumetric flow rate measuring device which is available for retrofitting. Otherwise, the connections are closed.

The control components comprise a controller with integrated static or dynamic sensor and an actuator with standard, quick or spring return. The controller with integrated sensor is mounted on an attachment console which can be tilted or offset manually in confined spaces.

Control and electrical connection of the DKpro pressure controller are analogue, by MP-Bus, BACnet or Modbus. All control components facilitate the operating modes "constant" and "variably adjustable 0 ... 10 V, 2 ... 10 V". Overrides, parallel operation and sequential circuits are possible.

Constant or variable set points which can be referenced as overpressure or negative pressure are specified. The differential pressure is measured. The positioning angle of the blades is then used for pressure control.

Factory settings can be ordered. Modifications by the user can be made using a setting device, including in conjunction with a PC or the integrated NFC interface with a smartphone.

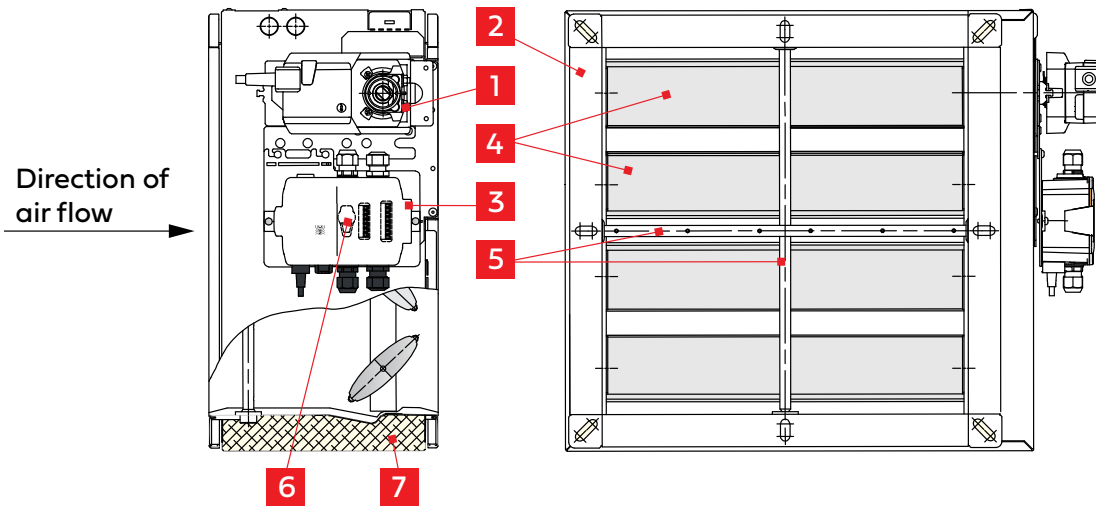

Item	Description
1	Duct casing
2	Actuator
3	Sensor and controller with detachable attachment console
4	Blades
5	Measuring cross
6	Service socket for setting device
7	Acoustic insulation with sheet metal jacket (optional)

Hygiene

DKpro Pressure controller

- meet the hygiene requirements according to VDI 6022-1, VDI 3803-1, DIN 1946-4, DIN EN 16798-3, SWKI VA104-01, SWKI VA105-01, ÖNORM H6020, ÖNORM H6021,
- are resistant to microbes, so they do not promote the growth of micro-organisms (fungi, bacteria),
- are resistant to cleaning agents and disinfectants,
- are suitable for cleaning and satisfy the requirements for surface and geometric design

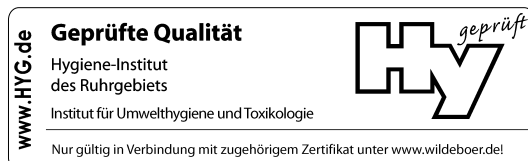

For further information and instructions ⇒ see hygiene certificate and operating instructions

Product description

DKpro pressure controller

3.1 Accuracy

DKpro pressure controllers make for high accuracy with only around $\pm 5\%$... $\pm 10\%$ deviation from the actual pressure. The sensor-related pressure ranges P_{start} to P_{nom} and the pressures preset for ventilation ducts or rooms are held constant within the hysteresis.

Pressure ranges	Sensors		
	Dynamic, up to 500 Pa	Static, up to 75 Pa	Static, up to 600 Pa
P_{limit} [Pa]	25	4	30
P_{start} [Pa]	25	8	60
P_{nom} [Pa]	500	75	600
Sensor accuracy	± 1 Pa in pressure range 0 ... 20 Pa $\pm 5\%$ in pressure range 2 Pa to P_{nom}		

3.2 Function of pressure control

DKpro pressure controllers control the static pressure in a ventilation duct or in a room to a specified set point. This set point can be constant, variable or specified by a reference variable. The control is based on a differential pressure measurement compared to a reference pressure.

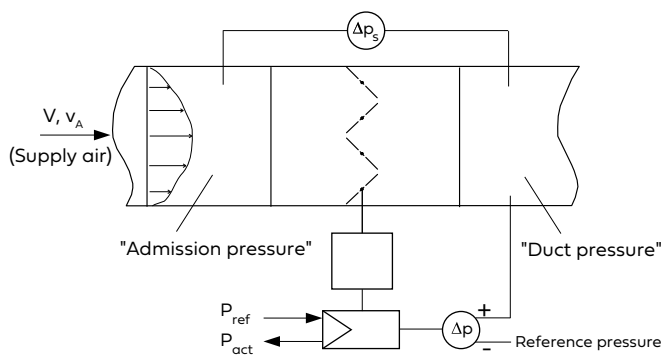

The control process closes or opens the blades in the pressure controller casing to a greater or lesser extent. This results in a change in the static pressure drop Δp_s .

As a result of the pressure drop, the pressure upstream of the pressure controller is always higher than the pressure downstream. The "primary pressure" generated by a fan is reduced to the "duct pressure" downstream of the pressure controller. Its actual value is measured at the pressure tapping point.

The actual value should correspond to the specified reference pressure P_{ref} within the designated tolerances.

The tolerance is made up of the sensor accuracy plus the control hysteresis = dead band $\pm 5\% P_{nom}$.

If the actual pressure deviates from the reference pressure by more than the control hysteresis specifies, the control system intervenes. A corresponding blade adjustment ensures that the actual pressure is returned to the tolerance range.

Area of application

A prerequisite for properly functional control is that the degree of throttling of the blades must be within a range suitable for the application.

In principle, the DKpro pressure controller should therefore be engineered to have the lowest possible pressure drops, not only from an economic perspective but also from a technical one.

3.3 Function of operating modes

The use of the operating modes requires the necessary electrical connections and the setting of the corresponding parameters. Pressure control begins as soon as the sensor signals to the controller that the differential pressure is above P_{limit} .

Setting the reference pressure from P_{start} leads to the specified accuracy in the pressure range up to P_{nom} . This must be taken into account for serviceable control in the lower pressure range.

Constant

For $P_{\text{min}} \leq P_{\text{nom}}$ a reference pressure is set. The purpose of this is to keep the controller constant.

Variable

With $P_{\text{min}} < P_{\text{max}}$ or $P_{\text{min}} = 0$ [Pa] and $P_{\text{max}} \geq 20\% P_{\text{nom}}$ a reference pressure range is set. Within it, the reference pressures P_{ref} to be kept constant by the controller can be specified by a command signal Y [V]. It is applied to terminal 3.

For bus operation see [page 22](#).

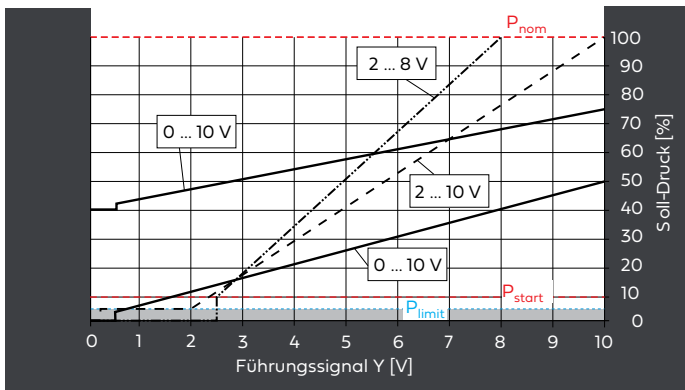

P_{start} depends on the sensor

Command signal Y:

0 ... 10 V

- If $P_{\text{min}} = 0$ [Pa] is set, the blades close completely at $Y = 0$ to 0.5 V. The control function begins from $Y \geq 0.5$ V. Illustration using the example $P_{\text{min}} = 0\%$ and $P_{\text{max}} = 50\%$.
- If $P_{\text{min}} > 0$ Pa is set, the control function starts at this value from $Y = 0$ V – without closing. In the process, adhere to the switching threshold of 0.5 V. Illustration using the example $P_{\text{min}} = 40\%$ and $P_{\text{max}} = 75\%$

→ For command signal Y , calculate the reference pressure P_{ref}^{***} :

$$P_{\text{ref}} [\text{Pa}] = P_{\text{min}} [\text{Pa}] + (P_{\text{max}} [\text{Pa}] - P_{\text{min}} [\text{Pa}]) \cdot Y [\text{V}] : 10 \text{ V} \quad [1]$$

2 ... 10 V

- If $0 \text{ V} \leq Y \leq 0.2 \text{ V}$, the blades close completely. If $0.2 \text{ V} < Y \leq 2 \text{ V}$, the control function starts with P_{min} . Illustration using the example $P_{\text{min}} = P_{\text{limit}}$, $P_{\text{max}} = P_{\text{nom}}$.
- If $P_{\text{min}} = 0$ [Pa] is set, the blades close completely at $Y = 0$ to 2.5 V. The control function begins from $Y \geq 2.5$ V.

→ For command signal Y , calculate the reference pressure P_{ref}^{***} :

$$P_{\text{ref}} [\text{Pa}] = P_{\text{min}} [\text{Pa}] + (P_{\text{max}} [\text{Pa}] - P_{\text{min}} [\text{Pa}]) \cdot (Y [\text{V}] - 2 \text{ V}) : 8 \text{ V} \quad [2]$$

Adjustable (Y from LL = 0 to 8 V DC to UL = 2 to 10 V DC)

LL and UL can be set as integers, where UL must always be at least 2 V greater than LL.

- If $LL = 0$ V, the functions correspond to 0 ... 10 V, but in combination with UL instead of 10 V.
- If $LL > 0$ V and $0 \text{ V} \leq Y \leq 0.2 \text{ V}$, the blades close completely. If $0.2 \text{ V} < Y \leq LL \text{ V}$, the control function starts with P_{min} .
- If $P_{\text{min}} = 0$ [Pa] is set, the blades close completely at $Y = 0$ to $LL + 0.5$ V. The control function begins from $Y \geq LL + 0.5$ V. Illustration using the example 2 to 8 V with $P_{\text{min}} = 0\%$ and $P_{\text{max}} = P_{\text{nom}}$

→ For command signal Y , calculate the reference pressure P_{ref}^{***} :

$$P_{\text{set}} [\text{Pa}] = P_{\text{min}} [\text{Pa}] + (P_{\text{max}} [\text{Pa}] - P_{\text{min}} [\text{Pa}]) \cdot (Y [\text{V}] - LL [\text{V}]) / (UL [\text{V}] - LL [\text{V}]) \quad [3]$$

***The pressures can also be used in [% P_{nom}] instead of [Pa]. Equation results apply to $P_{\text{ref}} > P_{\text{limit}}$. For examples, see [page 10](#).

Product description

DKpro pressure controller

Override

Overrides require electrical connections with 24 V AC/DC voltage signals on the terminals 11 and 12. Analogue and bus controls can be used.

The signals override all operating modes and allow the blades to open or close fully. Additionally, the operating levels motor stop and P_{max} can be forced. See [page 22](#).

Actual value signal U

For analogue or BACnet / Modbus operation of the pressure controllers, an actual value signal U proportional to the actual pressure P_{act} is available on terminal 5 for external pressure display and as a command signal for sequential circuits.

It is proportional to the maximum pressure P_{nom} and independent of the settings on the pressure controller.

The voltage range can be set from LL = 0 ... 8 V DC to UL = 2 ... 10 V DC.

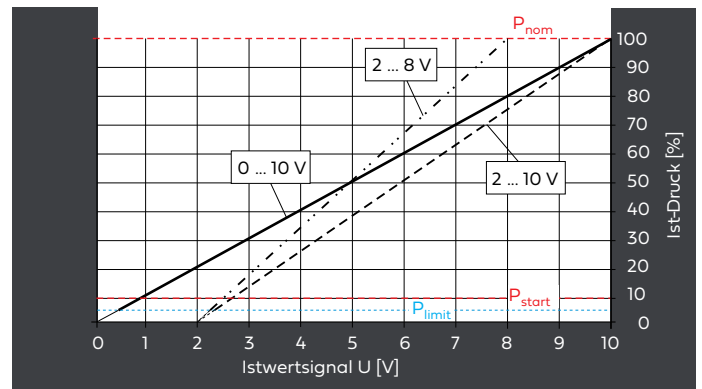

P_{start} depends on the sensor

In general, the following applies:

$$P_{act} [Pa] = P_{nom} [Pa] \cdot (U [V] - LL [V]) : (UL [V] - LL [V]) \quad [1a]$$

$$U [V] = LL [V] + (UL [V] - LL [V]) \cdot P_{act} [Pa] : P_{nom} [Pa] \quad [1b]$$

For pressure control in the voltage ranges 0 ... 10 V or 2 ... 10 V, the following applies:

- For constant operation, the actual value signal U can be ordered in these two settings.
- For variable operation, the voltage range of the actual value signal U is matched to the command signal Y.

In both cases, formulas [1a] and [1b] apply:

$$0 \dots 10 \text{ V:} \quad P_{act} [Pa] = P_{nom} [Pa] \cdot U [V] : 10 \text{ V} \quad [2a]$$

$$U [V] = 10 \text{ V} \cdot P_{act} [Pa] : P_{nom} [Pa] \quad [2b]$$

$$2 \dots 10 \text{ V:} \quad P_{act} [Pa] = P_{nom} [Pa] \cdot (U [V] - 2 \text{ V}) : 8 \text{ V} \quad [3a]$$

$$U [V] = 2 \text{ V} + 8 \text{ V} \cdot P_{act} [Pa] : P_{nom} [Pa] \quad [3b]$$

3.3.1 Stand-alone operation, parallel operation and master-slave sequential operation – examples

With stand-alone operation, the pressure controller is set to one of the possible operating modes.

With parallel operation, this affects two or more. The command signals are always identical and are connected electrically individually or in parallel to terminal 3 (command signal Y). When connected in parallel, controllers operate independently of one another. Reference pressures P_{\min} and P_{\max} can be set independently of each other and according to the size and operating modes of the controllers. Changes to one controller have no effect on the others.

With master-slave sequential operation, the actual pressure P_{act} of one controller controls the reference pressure P_{ref} of others.

In the case of analogue control, the actual value signal U from terminal 5 of the master controller is fed as the command signal Y to terminal 3 of the slave controllers.

If the master is set to "variable 0 ... 10 V", "variable 2 ... 10 V" or "variable adjustable", the same mode must be set on the slave. If a master operates in "constant" mode, the slave must be operated in "variable" mode and must be matched to the master's output signal (0 ... 10 V or 2 ... 10 V).

Example 1: Stand-alone operation of the pressure controllers (static sensor up to 600 Pa) and parallel operation with identical pressure

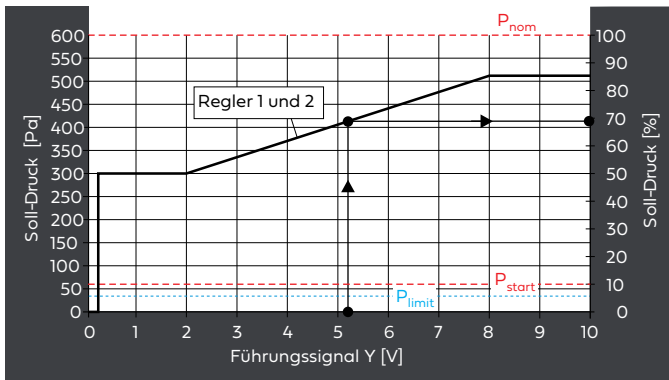

If the "variable adjustable" operating mode is set to 2 ... 8 V, the control range is controlled with $Y = 2 \dots 8 \text{ V}$ as the command signal.

With $P_{\min} = 50 \% P_{\text{nom}}$ and $P_{\max} = 85 \% P_{\text{nom}}$, a reference pressure range is specified.

In accordance with [page 8](#), formula [\[3\]](#), with $Y = 2 \text{ V}$ as the "command signal", the result is:

$$P_{\text{ref}} [\%] = 50 \% + (85 \% - 50 \%) \cdot (2 \text{ V} - 2 \text{ V}) : (8 \text{ V} - 2 \text{ V}) = 50 \% P_{\text{nom}}$$

When $Y = 5.2 \text{ V}$ is selected as command signal between 2 and 8 V:

$$P_{\text{ref}} [\%] = 50 \% + (85 \% - 50 \%) \cdot (5.2 \text{ V} - 2 \text{ V}) : (8 \text{ V} - 2 \text{ V}) = 69 \% P_{\text{nom}}$$

With $Y = 8 \text{ V}$ as the greatest command signal:

$$P_{\text{ref}} [\%] = 50 \% + (85 \% - 50 \%) \cdot (8 \text{ V} - 2 \text{ V}) : (8 \text{ V} - 2 \text{ V}) = 85 \% P_{\text{nom}}$$

Example 2: Parallel operation of the pressure controllers (static sensor up to 600 Pa) with constant pressure difference

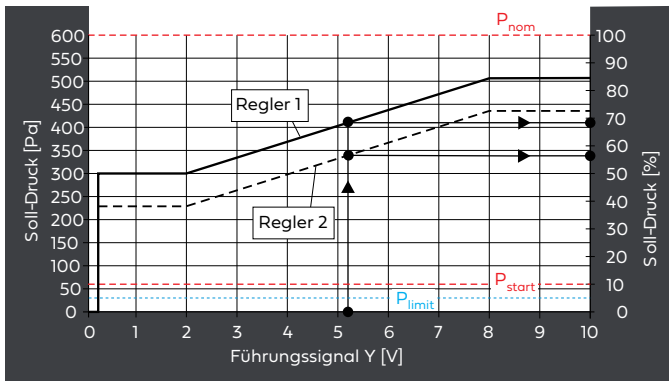

If the "variable adjustable" operating mode is set to 2 ... 8 V, the control range is controlled with $Y = 2 \text{ to } 8 \text{ V}$ as the command signal.

With $P_{\min} = 50 \% P_{\text{nom}}$ and $P_{\max} = 85 \% P_{\text{nom}}$ on controller 1, a reference pressure range is specified.

In accordance with [page 8](#), formula [\[3\]](#), the result for e.g. $Y = 5.2 \text{ V}$ as a possible command signal between 2 and 8 V is:

$$P_{\text{ref}} [\%] = 50 \% + (85 \% - 50 \%) \cdot (5.2 \text{ V} - 2 \text{ V}) : (8 \text{ V} - 2 \text{ V}) = 69 \% P_{\text{nom}}$$

If a constantly 12 % lower pressure is to be set on controller 2, $P_{\min} = 38 \% P_{\text{nom}}$ and $P_{\max} = 73 \% P_{\text{nom}}$ must be set on it.

Then, with $Y = 5.2 \text{ V}$,

$$P_{\text{ref}} [\%] = 38 \% + (73 \% - 38 \%) \cdot (5.2 \text{ V} - 2 \text{ V}) : (8 \text{ V} - 2 \text{ V}) = 57 \% P_{\text{nom}}$$

Example 3: Parallel operation of the pressure controllers (static sensor up to 600 Pa) with equal-percentage pressure difference.

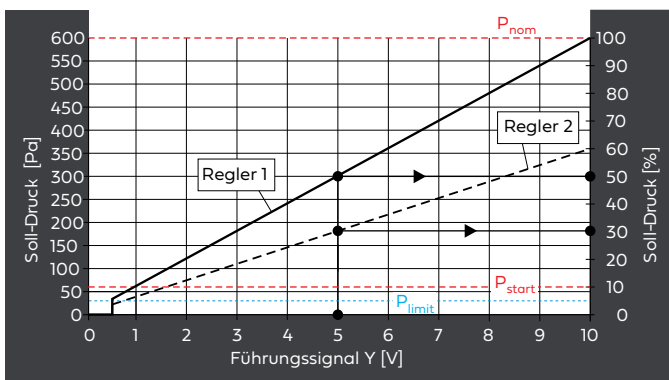

If "variable 0 ... 10 V" operating mode is set on the controllers, the control range is controlled with $Y = 0 \dots 10 \text{ V}$ as the command signal. With $P_{\min} = 0 \% P_{\text{nom}}$ and $P_{\max} = 100 \% P_{\text{nom}}$ on controller 1, a first reference pressure range is specified.

In accordance with [page 8](#), formula [\[3\]](#), for e.g. $Y = 5 \text{ V}$ as a possible command signal between 0 and 10 V, the result is:

$$P_{\text{ref}} [\%] = 0 \% + (100 \% - 0 \%) \cdot 5 \text{ V} : 10 \text{ V} = 50 \% P_{\text{nom}}$$

If a constantly 40 % lower pressure is to be set on controller 2, $P_{\min} = 0 \% P_{\text{nom}}$ and $P_{\max} = 60 \% P_{\text{nom}}$ must be set on it.

Then, with $Y = 5 \text{ V}$ on the other hand:

$$P_{\text{ref}} [\%] = 0 \% + (60 \% - 0 \%) \cdot 5 \text{ V} : 10 \text{ V} = 30 \% P_{\text{nom}}$$

Product description

DKpro pressure controller

3.4 Applications

Preparation for pressure control:

A mandatory prerequisite for functioning pressure control using the DKpro pressure controller is a tapping point to be provided on site for the measurement of the static pressure to be regulated. It is required for both duct pressure control and room pressure control.

Duct pressure control:

When it comes to duct pressure control, the DKpro pressure controller is ideally supplemented with the optionally available pressure tapping set. The static pressure to be regulated in the duct is captured by the pressure tapping point and fed to the differential pressure sensor of the DKpro pressure controller via the hose which has to be laid on site.

Duct pressure control is carried out as differential pressure control. The ambient pressure in the vicinity of the pressure controller serves as the reference pressure. For this purpose, the respective sensor connection remains free. For duct pressure control, sensors with measuring ranges of up to 500 Pa or 600 Pa are recommended.

The hose connection on the sensor is different for positive pressure or negative pressure control.

⇒ See the operating instructions, installation instructions

For solid pressure control, the pressure tapping point in a ventilation duct must be installed in a suitable position at a sufficient distance from obstructions. See ► [page 15](#)

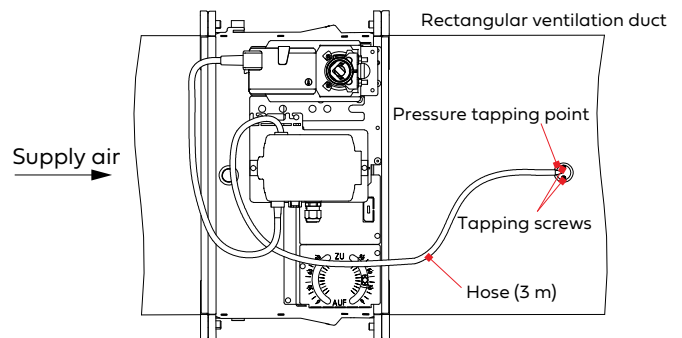

Room pressure control:

When it comes to room pressure control, the static pressure to be regulated in the respective room is detected using a room pressure sensor and fed to the differential pressure sensor of the DKpro pressure controller via a hose which has to be laid on site. For room pressure control, a sensor with a measuring range up to 75 Pa is recommended.

The pressure tapping point in the room must be positioned so that the pressure is detected without turbulence and is thus not adversely affected by any room currents. Each application must always be considered individually. It is often advisable to capture the static pressure in the area of the room ceiling. See ► [page 15](#)

Room pressure control is also carried out as a differential pressure measurement; a position with stable ambient pressure must be chosen as the reference pressure, e.g. an unventilated room or the external atmospheric pressure independent of wind pressure.

Supplementing the DKpro pressure controller with a volumetric flow rate measuring device:

The DKpro pressure controller can optionally be retrofitted with the VD or VS volumetric flow rate measuring device. It is used to determine the actual volumetric flow rate and thus makes it possible to dispense with complex network measurements when calibrating a ventilation system.

In system operation, the actual volumetric flow rate can, for example, be used for a possible sequential control or can be transmitted to a higher-level building control system. The actual value signal U is set to 0 ... 10 V in the factory.

The on-site connection to the measurement cross of the DKpro pressure controller is made using the supplied hoses.

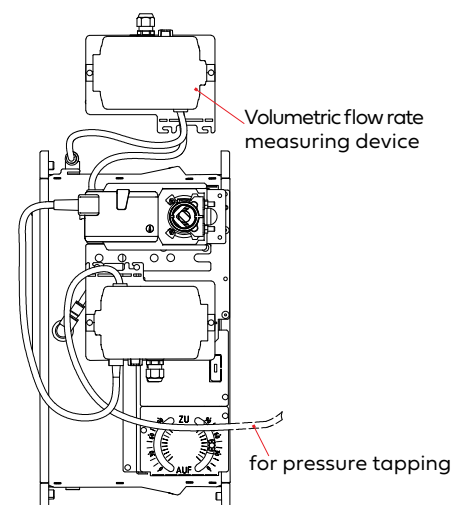

Product description

DKpro pressure controller

Reliable and noise-optimised operation of volumetric flow rate limiters

The use of DKpro pressure controllers in ventilation ducts ensures optimised and reliable operation of volumetric flow rate limiters. At the same time, acoustic optimisation can be performed.

In the application example, the DKpro pressure controller is used for this purpose in the secondary line of a supply air duct network. It regulates and limits the static positive pressure. Pressure fluctuations in the upstream duct network are offset, and the reference pressure P_{ref} in the secondary line is kept constant. This control system thus ensures the reliable operation of the volumetric flow rate limiters within their application limits. This means that both the minimum differential pressure is maintained and protection from excessive mechanical strain due to excessively high differential pressures is provided. If operation of the volumetric flow rate limiters can be limited to low pressure drops, this also has a positive effect on noise levels. Flow noise from the volumetric flow rate limiters in the branches, and thus the sound pressure level in the room, are minimised, meaning that the sound attenuators which are otherwise usual in the branches, can be omitted.

The reference pressure P_{ref} to be regulated is determined within the scope of the system engineering with the corresponding duct network calculation. The reference pressure in the application shown should be regulated at the start of the secondary line. It should be selected so that the volumetric flow rate limiter in the branch with the lowest duct losses operates reliably within its permissible differential pressure range. In addition, the volumetric flow rate limiter in the branch with the greatest duct losses must still be able to limit the set volumetric flow rate.

Application example

The actuator is a high-speed design which is combined with a controller with an integrated dynamic sensor for up to 500 Pa. The volumetric flow rate for each air diffuser is calibrated automatically by the volumetric flow rate limiters; this can also be performed manually using dampers.

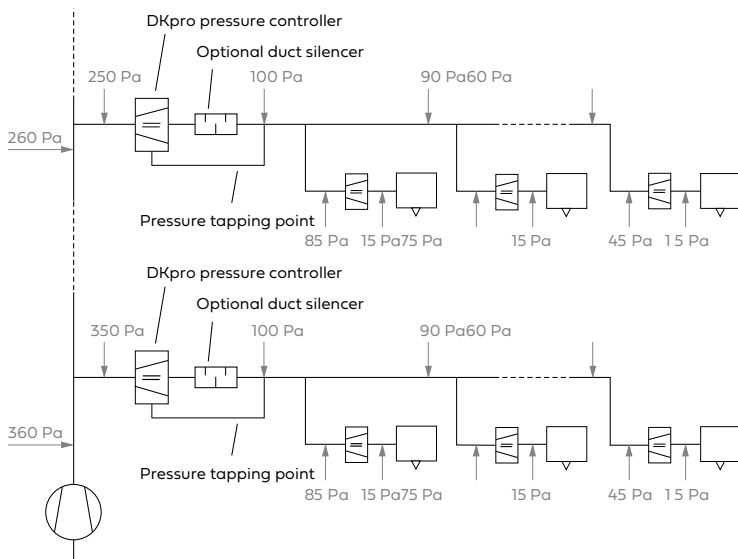

In the example, the pressure generated by the fan, minus the duct pressure drops, initially continues to all DKpro pressure controllers. They regulate and limit the static positive pressure in the secondary lines to 100 Pa. Pressure fluctuations in the duct network upstream of the pressure controllers are offset.

Thus, pressures in the range of 85 to 45 Pa are present in the branches of all secondary lines. This ensures that the pressure drops of all volumetric flow rate limiters, at 70 to 30 Pa, always remain within the permissible application range, and at the same time, the pressure drops are limited to low values, which leads to low flow noise. Sound attenuators in the branches are not required.

Flow noise in the secondary lines can be reduced if necessary by using the optionally available SKE-V sound attenuators.

3.5 Accessories

3.5.1 Acoustic insulation with sheet metal jacket

The acoustic insulation with sheet metal jacket for reducing radiated noise is supplied factory-mounted.

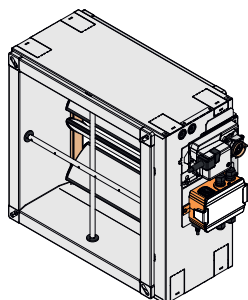

Reduction of radiated noise:

Reduction
-6 dB

For further technical data, see ► [WiDim](#).

Product description

DKpro pressure controller

3.5.2 SKE-V sound attenuator

The SKE-V sound attenuator for reducing flow noise is supplied separately. Assembly is performed with the pressure controller on site.

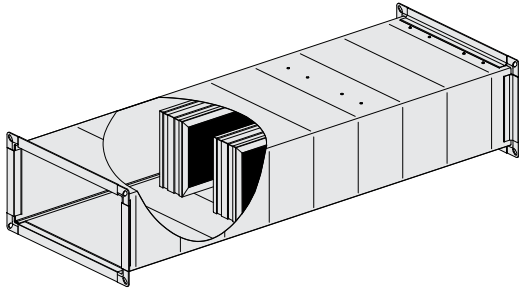

For further technical data, see ► [user manual for SKE](#) or ► [WiDim](#).

3.5.3 Link.10

Universal setting and diagnostics tool for actuators and controllers. It serves as a Bluetooth and USB-to-NFC and MP-Bus converter, enabling user-friendly configuration, commissioning and fault diagnosis.

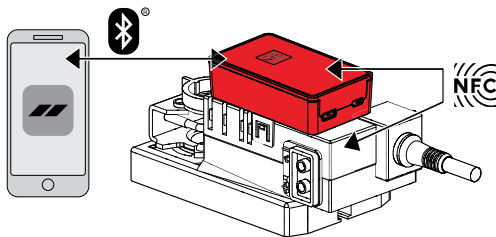

3.5.4 Volumetric flow rate measuring device

Volumetric flow rate measuring device for measuring and displaying the actual volumetric flow rate and for subsequent controls. It comprises a console with a controller with an integrated dynamic or static sensor. The measurement cross included in the pressure controller must be connected using the supplied hoses.

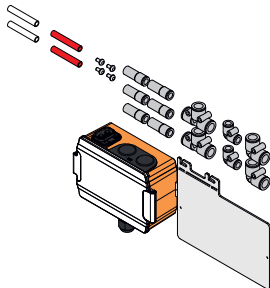

3.5.5 Pressure tapping set

Pressure tapping set for detecting the static pressure in the ventilation duct upstream and downstream of the pressure controller. It comprises the pressure tapping point, the push-on tube for bridging walls with insulation with a thickness of up to 80 mm, 3 m of hose for connection to the sensor of the DKpro pressure controller, fastening screws and a seal.

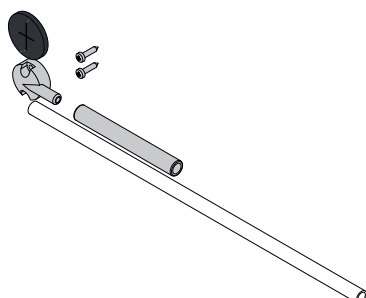

Product description

DKpro pressure controller

3.6 Installation

The DKpro pressure controller is installed position-independently and in the air direction indicated on the label. To ensure lasting function and leak tightness, tension-free installation in ventilation ducts is a prerequisite.

Space requirement

To enable the commissioning and servicing work to be carried out, sufficient space should be kept free in the area of any attachment parts. Inspection openings of sufficient size may required so that the attachments are easily accessible.

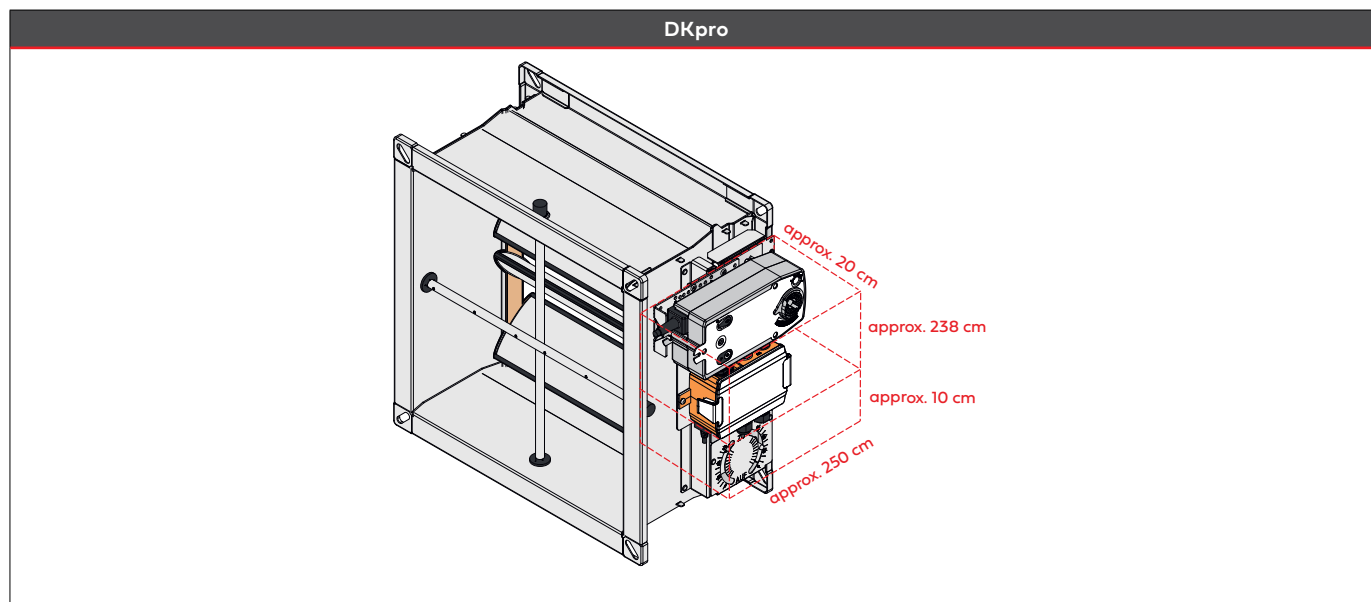

3.7 Installation information / clearances to obstructions

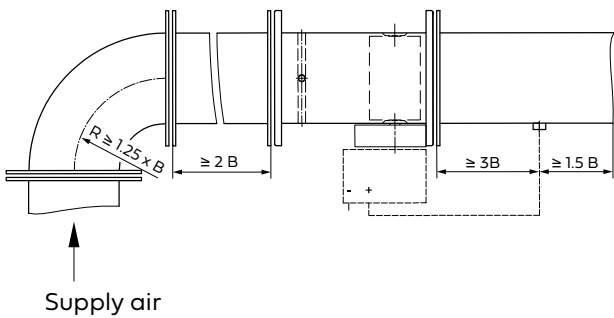

Fig. Installation downstream of a bend for supply air

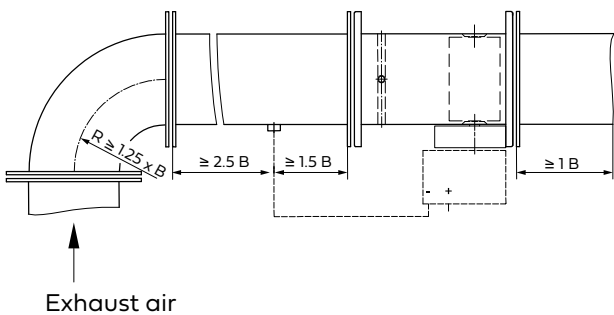

Fig. Installation downstream of a bend for exhaust air

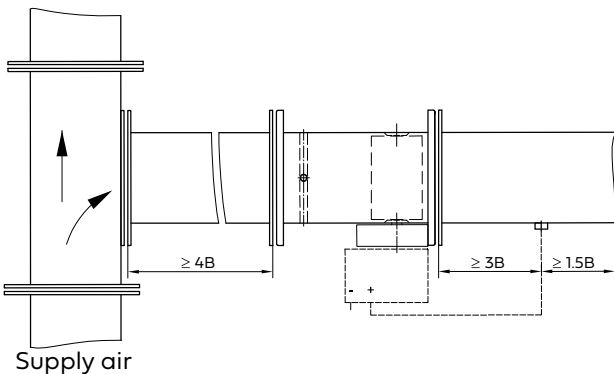

Fig. Installation downstream of a T connector for supply air

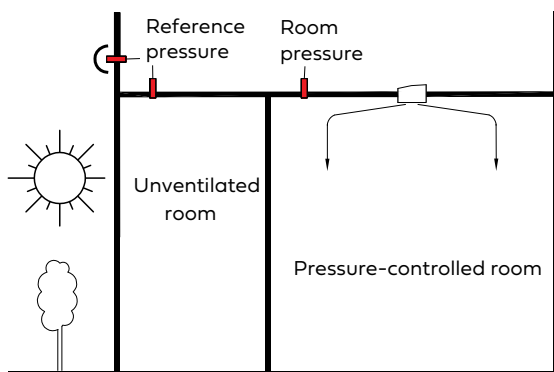

Fig. Positioning of the room pressure tapping point and selection of the reference pressure

Installation instructions are supplied together with delivery of the DKpro pressure controller, and must be observed.

- DKpro pressure controllers are designed for ventilation and air conditioning systems. Suitable air purity is a prerequisite for operation.
- DKpro pressure controllers are parametrised for the entire controllable pressure range from P_{start} to P_{nom} and achieve the specified accuracy in this range. Greater fluctuations can occur at low pressures.
- Optimum function of the DKpro pressure controllers in duct pressure control requires a suitable placement of the pressure tapping point on the ventilation duct. When supplementing the pressure controllers with a volumetric flow rate measuring device, the straight upstream and downstream sections shown in the examples should be adhered to as a minimum downstream of obstructions. When it comes to duct pressure control, multiple obstructions in a row can be compensated for by shifting the pressure tapping point; for determining the volumetric flow rate, a longer upstream section may be required in this case, otherwise greater fluctuations must be expected. For room pressure control, the pressure tapping points for both the room pressure and the reference pressure must be selected appropriately.
- DKpro pressure controllers can be inserted position-independently.
- DKpro pressure controllers are supplied from the factory with the blades open and with either the standard setting or a customer-specific presetting.
- If there is no system operating pressure, the blades are open. If the pressure increases to the specified set point, the DKpro pressure controllers enter into operation.
⇒ For application limits, see [page 18](#) and [page 19](#)
- The actuators are overload-proof. Standard and high-speed actuators remain in their current position in the event of a power failure. Spring return actuators perform the emergency positioning movement (closing or opening) using a spring. In the process, all settings remain in place.
- On-site changes to the setting values can be made using the Link.10 setting device; additionally, with the appropriate communication software, this can also be performed on a PC or a smartphone.
- DKpro pressure controllers and SKE-V sound attenuators are supplied individually. They are assembled on site; in doing so always align the gap in the splitter at a right angle to the blade axis.

Technical data

DKpro pressure controller

4 Technical data

Technical data		
Sizes W x H	200 x 100 mm ... 1000 x 1000 mm	
Control ranges		
Volumetric flow rate	72 ... 36000 m ³ /h****	
Pressure	up to 600 Pa****	
Flow velocity	1 ... 10 m/s	
Minimum differential pressure	5 Pa	
Maximum differential pressure	1000 Pa	
Areas of application		
Differential pressure	0 ... 1000 Pa	
Operating temperature	0 ... +50 °C	
Storage temperature	0 ... +40 °C (NMQ24A-VST only)	
Relative humidity	≤ 95 %, non-condensing	
Classifications		
Leak tightness class	Casing: ATC 3 (formerly C) in accordance with DIN EN 1751 Damper blade: Leak tightness class 4 in accordance with DIN EN 1751	
Protection class	III safety extra-low voltage	
Protection rating	IP42 in accordance with DIN EN 60529	
Approvals / certificates		
Environmental Product Declaration in accordance with DIN EN 15804	EPD-WIL-20230373-ICAI-DE, issued by: Institut Bauen und Umwelt e. V., Berlin	
Hygiene certificate in accordance with VDI 6022	W-408912-25-JRoll, issued by: Hygiene Institut des Ruhrgebiets, Gelsenkirchen	
Conformities		
Electromagnetic compatibility	2014/30/EU	
Machinery Directive	2006/42/EG	
RoHS2	2011/65/EU	
Actuators		
Voltage supply	24 V AC/DC, -10 %, +20 %	
Power consumption of actuators with controller [runtime for approx. 90°].		
<i>Standard actuator with controller</i>		
LM24A-VST	W x H: 200 x 100 ... 300 x 100, 400 x 100, 500 x 100, 600 x 100	2.5 W, 4 VA [approx. 120 s]
NM24A-VST	W x H: 300 x 200, 300 x 300, 400 x 200 ... 400 x 400, 500 x 200 ... 500 x 500, 600 x 200 ... 600 x 400, 700 x 200 ... 700 x 400, 800 x 200 ... 800 x 400, 900 x 300, 1000 x 300	3.5 W, 6 VA [approx. 120 s]
SM24A-VST	W x H: 600 x 500, 600 x 600, 700 x 500, 800 x 500 ... 800 x 800, 900 x 300, 900 x 400, 1000 x 400 ... 1000 x 1000	
<i>High-speed actuator with controller</i>		
NMQ24A-VST	W x H: 200 x 100 ... 500 x 300, 600 x 100 ... 600 x 300, 700 x 200, 800 x 200	14.5 W, 25 VA [approx. 4 s]
SMQ24A-VST	W x H: 500 x 400, 500 x 500, 600 x 400 ... 600 x 600, 700 x 300 ... 700 x 500, 800 x 300 ... 1000 x 1000	16.5 W, 28 VA [approx. 7 s]
<i>Spring return actuator with controller</i>		
NF24A-VST	W x H: 200 x 100 ... 600 x 400, 700 x 200 ... 700 x 400, 800 x 200 ... 800 x 400, 900 x 300, 1000 x 300	6.5 W, 10 VA [approx. 120 s emergency positioning approx. 20 s]
SF24A-VST	W x H: 600 x 500, 600 x 600, 700 x 500, 800 x 500, 800 x 600, 800 x 800, 900 x 400, 900 x 500, 1000 x 400 ... 1000 x 1000	10 W, 13 VA [approx. 120 s emergency positioning approx. 20 s]
Control		
Command signal, analogue	0 ... 10 V DC, 2 ... 10 V DC, adjustable (0 ... 10 V DC)	
Actual value signal, analogue	0 ... 10 V DC, 2 ... 10 V DC, adjustable (0 ... 10 V DC)	
Bus operation	MP-Bus, Modbus RTU, BACnet MS/TP	

Weights

DKpro pressure controller with standard actuator [with acoustic insulation]

Weights in kg

		Height [mm]							
		100	200	300	400	500	600	800	1000
Width [mm]	200	7.1 [8.9]	9.4 [11.9]	-	-	-	-	-	-
	300	8.3 [10.5]	10.9 [13.8]	12.9 [16.2]	-	-	-	-	-
	400	9.3 [11.8]	12.1 [15.3]	14.2 [17.8]	16.3 [20.1]	-	-	-	-
	500	10.5 [13.4]	13.5 [17.0]	15.7 [19.7]	17.9 [22.1]	20.2 [24.8]	-	-	-
	600	11.7 [15.0]	14.8 [18.8]	17.2 [21.6]	19.5 [24.2]	22.2 [27.2]	24.6 [30.1]	-	-
	700	-	16.1 [20.5]	18.7 [23.5]	21.2 [26.2]	24.0 [29.4]	-	-	-
	800	-	17.5 [22.2]	20.2 [25.3]	22.8 [28.3]	25.8 [31.6]	28.5 [34.8]	34.0 [41.1]	-
	900	-	-	21.7 [27.2]	24.7 [30.5]	27.6 [33.8]	-	-	-
	1000	-	-	23.2 [29.1]	26.3 [32.5]	29.3 [36.0]	32.4 [39.5]	38.5 [46.4]	44.6 [53.3]

**** Specifications depending on size

***** Specifications depend on the sensor being used

Technical data

DKpro pressure controller

4.1 Dimensions

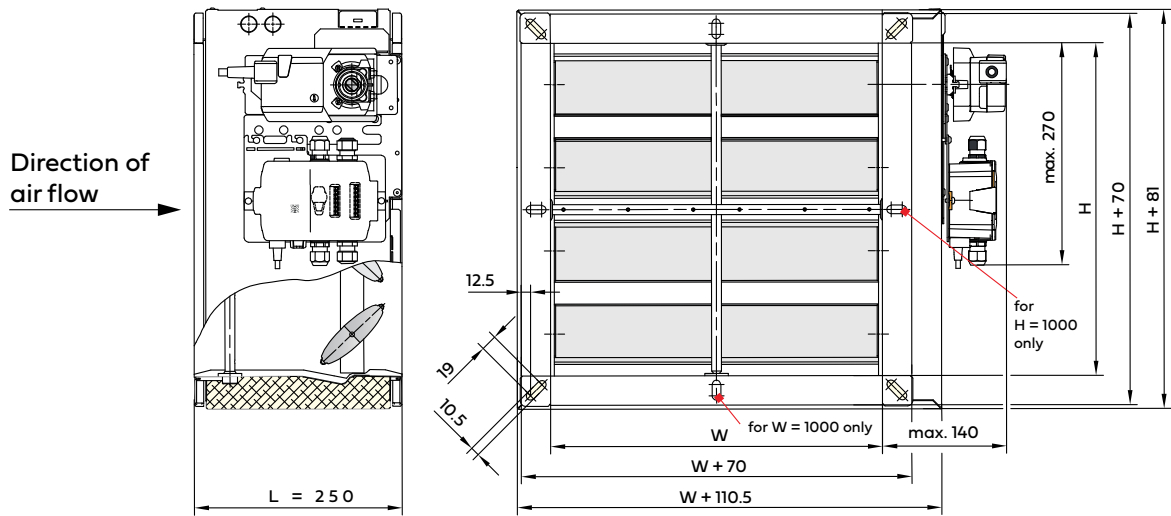

4.1.1 SKE-V sound attenuator

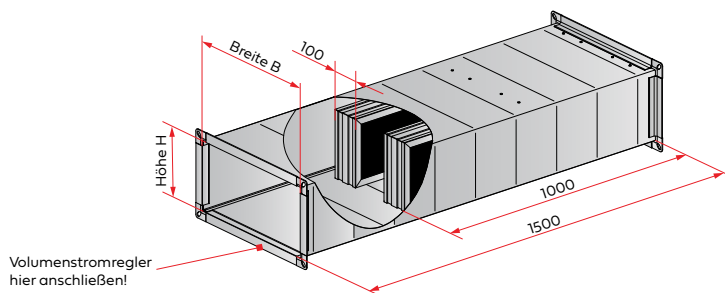

Number of splitters

Width W [mm]	Height H [mm]							
	100	200	300	400	500	600	800	1000
200	-				1			
300	-				1			
400	-				2			
500	-				2			
600	-				3			
700	-				3			
800	-				4			
900	-				4			
1000	-				5			

For further technical data, see [► user manual for SKE](#) or [► WiDim](#).

4.2 Sound power level inside the ventilation duct – flow noise

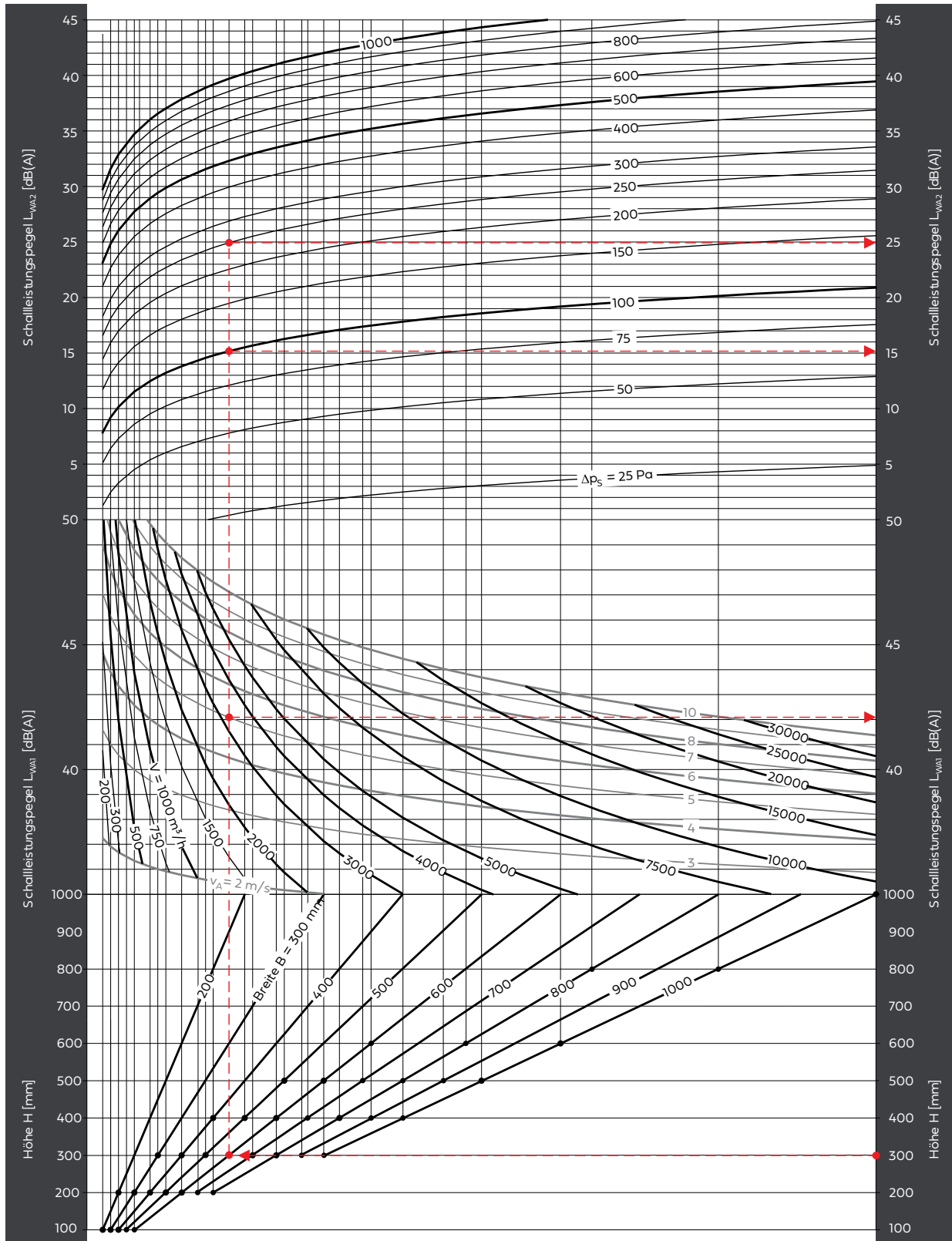

For nomenclature, see [page 20](#)
 For examples, see [page 20](#)

In the above nomogram, the sound power level inside the ventilation duct is dimensioned as an overall level $L_{w,WA}$. Octave sound power levels L_{w-Oct} for every size and any required operating point are obtained from the WILDEBOER dimensioning software.

See download at www.wildeboer.de

4.3 Sound power level outside the ventilation duct – radiated noise

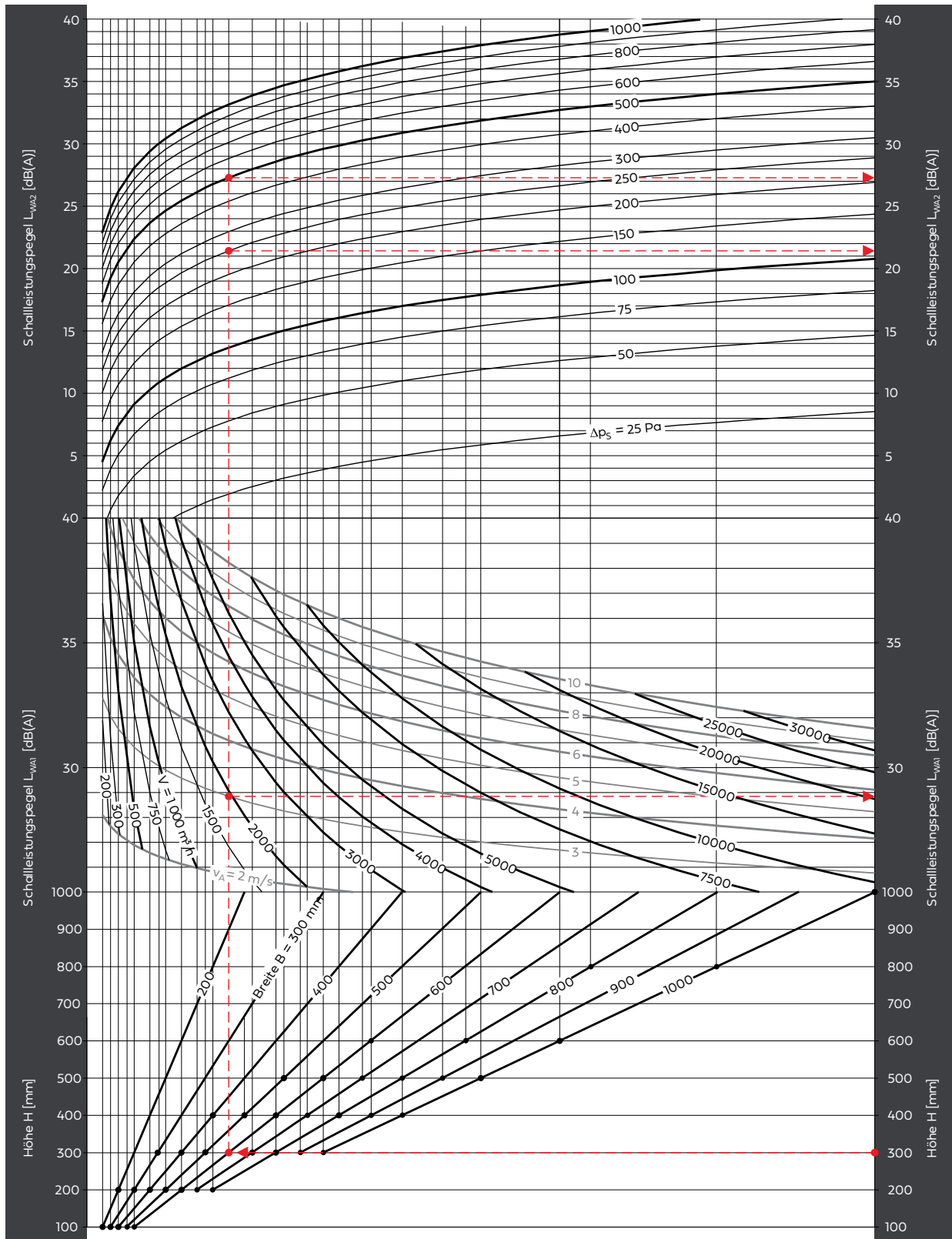

For nomenclature, see [page 20](#)
 For examples, see [page 20](#)

In the above nomogram, the sound power level inside the ventilation duct is dimensioned as an overall level L_{WA1} . Octave sound power levels L_{W-Oct} for every size and any required operating point are obtained from the WILDEBOER dimensioning software.

See download at www.wildeboer.de

4.4 Sound power level inside / outside the ventilation duct – examples

For example, see [▶ page 18](#)

Specified:	Width	W	=	600	mm
	Height	H	=	300	mm
	Volumetric flow rate	\dot{V}	=	3240	m ³ /h
	Velocity v_A		=	5.0	m/s
	Static pressure drop	Δp_s	=	100	Pa

Result:	Sound power level	L_{WA1}	=	42.1	dB(A)
		L_{WA2}	=	15.2	dB(A)
		$L_{WA} = L_{WA1} + L_{WA2}$	=	57.3	dB(A)

For example, see [▶ page 18](#)

Specified:	Width	W	=	600	mm
	Height	H	=	300	mm
	Volumetric flow rate	\dot{V}	=	3240	m ³ /h
	Velocity v_A		=	5.0	m/s
	Static pressure drop	Δp_s	=	250	Pa

Result:	Sound power level	L_{WA1}	=	42.1	dB(A)
		L_{WA2}	=	25	dB(A)
		$L_{WA} = L_{WA1} + L_{WA2}$	=	67.1	dB(A)

- The sound power levels inside the connecting duct are calculated in the nomograms as A-weighted overall levels L_{WA} .
- Corresponding octave sound power levels L_{W-Oct} can be calculated for every size and all operating points using the Wildeboer dimensioning software; also for designs with additional SKE-V sound attenuator.
- With SKE-V sound attenuators, the sound power levels L_{WA} can be reduced by up to 16 dB.

Important:

The sound levels indicated in the nomograms are stated as sound power levels! They represent the sound energy introduced into the duct system. They are used for acoustic calculations, e.g. when adding sound attenuators.

In other documents, sound pressure levels L_p or L_{pA} are frequently specified instead of sound power levels. They include general attenuations of up to 21 dB. This distinction must be taken into account when comparing numeric values. Furthermore, the extent of these attenuations only becomes clear once the ducts, baffles, branches and spaces have actually been connected.

For example, see [▶ page 19](#)

Specified:	Width	W	=	600	mm
	Height	H	=	300	mm
	Volumetric flow rate	\dot{V}	=	2592	m ³ /h
	Velocity v_A		=	4.0	m/s
	Static pressure drop	Δp_s	=	250	Pa

Result:	Sound power level ¹	L_{WA1}	=	28.9	dB(A)
		L_{WA2}	=	21.3	dB(A)
		$L_{WA} = L_{WA1} + L_{WA2}$	=	50.2	dB(A)

For example, see [▶ page 19](#)

Specified:	Width	W	=	600	mm
	Height	H	=	300	mm
	Volumetric flow rate	\dot{V}	=	2592	m ³ /h
	Velocity v_A		=	4.0	m/s
	Static pressure drop	Δp_s	=	500	Pa

Result:	Sound power level ¹	L_{WA1}	=	28.9	dB(A)
		L_{WA2}	=	27.2	dB(A)
		$L_{WA} = L_{WA1} + L_{WA2}$	=	56.1	dB(A)

Nomenclature

\dot{V}	[m ³ /h]	Volumetric flow rate
\dot{V}_{act}	[m ³ /h]	Actual volumetric flow rate
P	[Pa]	Pressure
P_{ref}	[Pa]	Reference pressure
P_{min}	[m ³ /h]	Minimum reference pressure
P_{max}	[m ³ /h]	Maximum reference pressure
P_{limit}	[m ³ /h]	Minimum pressure to be set
P_{start}	[m ³ /h]	Minimum controllable pressure
P_{nom}	[m ³ /h]	Maximum controllable pressure
$P_{start} - P_{nom}$	[m ³ /h]	Operating range of the pressure controller
P_{act}	[Pa]	Actual pressure
A_A	[m ²]	Inflow cross section = W x H
v_A	[m/s]	Flow velocity in A_A
Δp_s	[Pa]	Static pressure drop
Δp	[Pa]	Differential pressure
L_{WA}	[dB(A)]	A-weighted sound power level
L_{W-Oct}	[dB]	Octave sound power level $L_{W-Oct} = L_{WA} + \Delta L$
L_p	[dB]	Sound pressure level
L_{pA}	[dB(A)]	A-weighted sound pressure level
U	[V]	Actual value signal
LL	[V]	Lower limit for Y and U
UL	[V]	Upper limit for Y and U

Electrical connection

DKpro pressure controller

5 Electrical connection

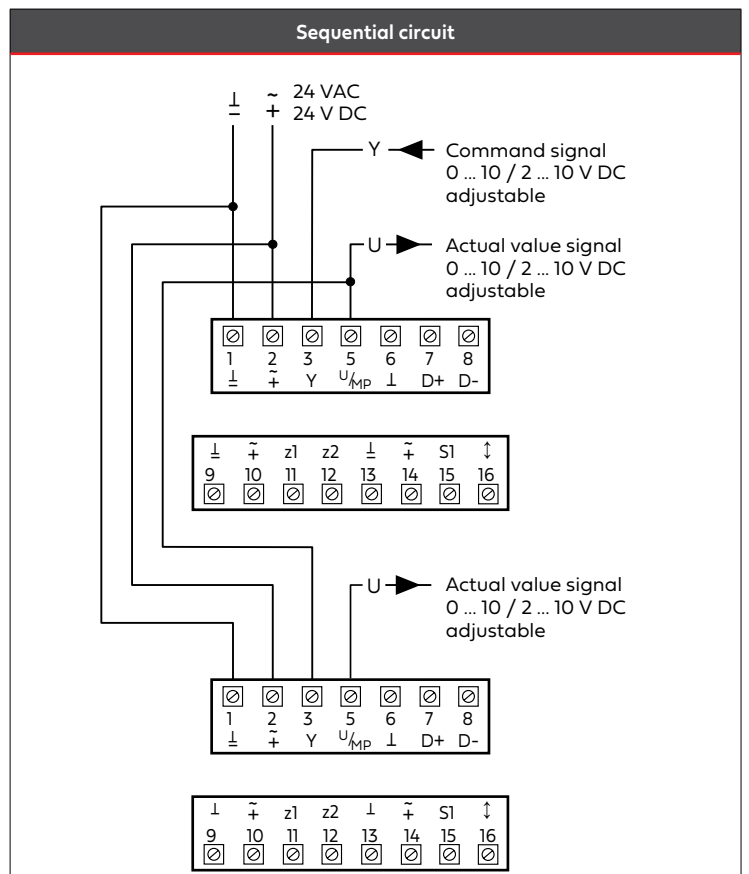
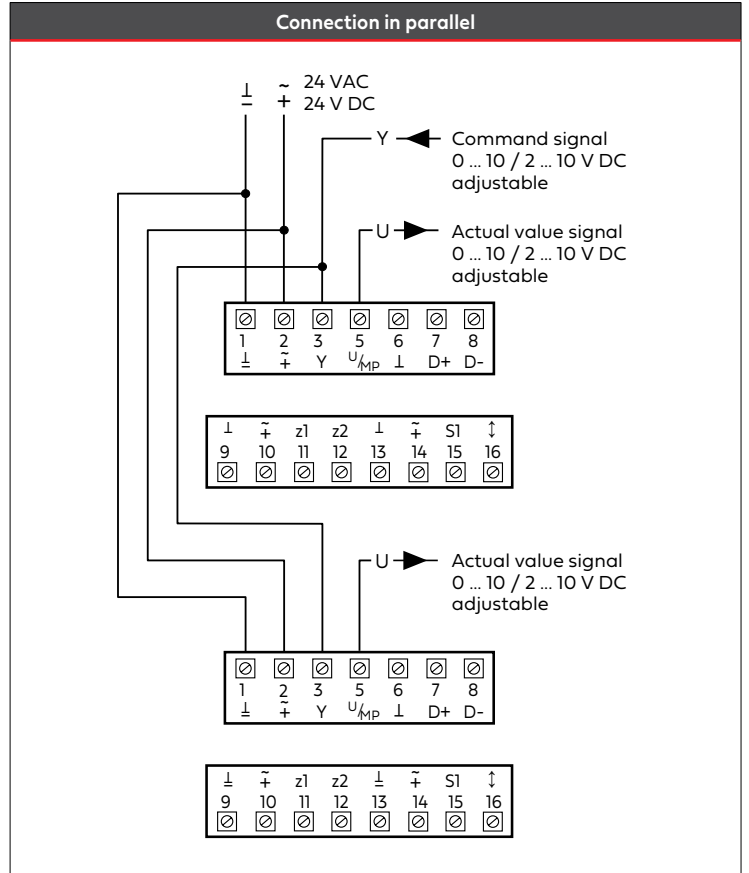
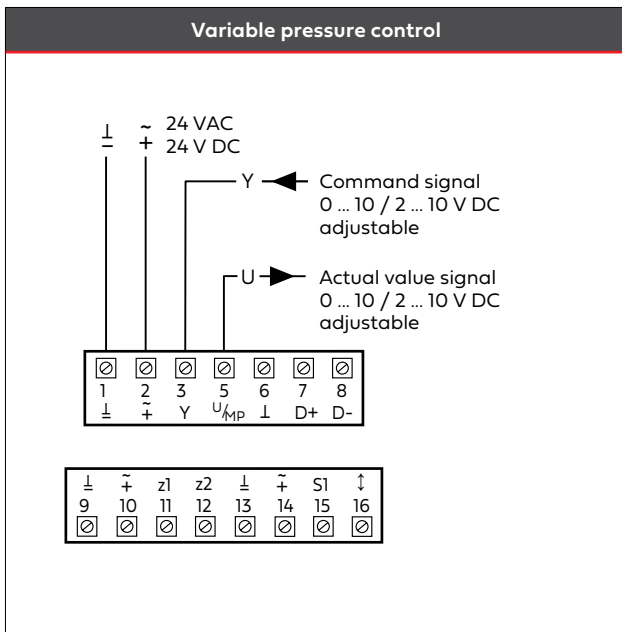
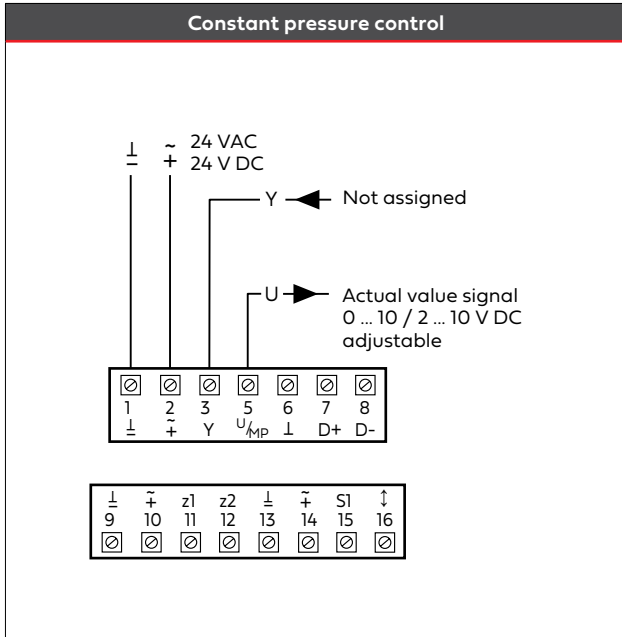

Electrical connection

DKpro pressure controller

Overrides in operating modes "constant" and "variable"

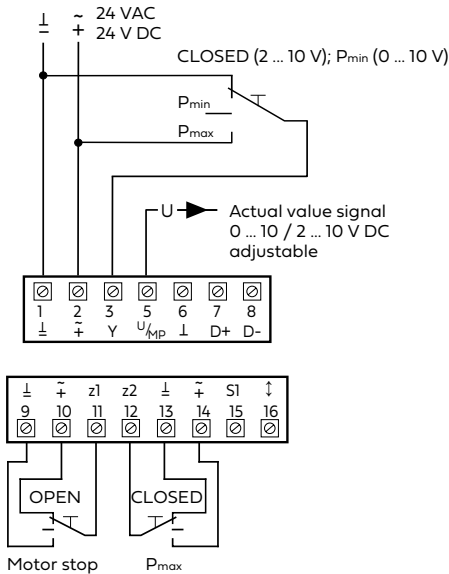

Override circuits must be provided on site. Make sure that the respective overrides (CLOSED, OPEN, motor stop, P_{min}, P_{max}) are interlocked to prevent a short circuit!

If there are signals on terminals 3, 11 and 12 simultaneously, the input on terminal 11 has the highest priority, followed by terminal 12. The input on terminal 3 has the lowest priority.

Bus operation

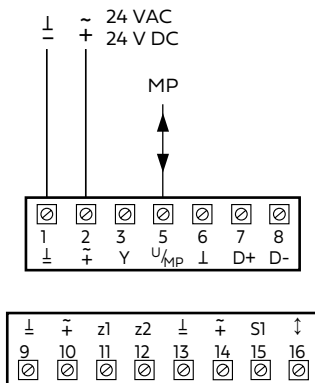

The DKpro pressure controller can be integrated into a higher-level building control system via MP-Bus. The bus connection on the controller can be established using conventional 3-core installation cables. The voltage supply on terminal 1 (GND) and terminal 2 (24 V) and the bus signal on terminal 5 are transmitted.

Function:

After an address has been assigned, bus operation starts automatically. The controller on the DKpro pressure controller represents one of a maximum of eight possible slaves (MP nodes) connected to an MP master. They receive their digital command signal from the MP master of the building control system (PLC or DDC controller with MP interface). The bidirectional function of the MP bus transmits the addressing, commands, set points, overrides and settings, such as P_{min} and P_{max}, to each slave. Each slave returns its identification and settings, the actual pressure, the blade position, status messages and, if applicable, the value (Ω, %, 0/1) of a connected sensor.

The reference variable MP is specified in % in MP bus operation. It is 0 % = P_{min}, 100 % = P_{max}.

Thus, the MP operating mode is similar to the "variable 0 ... 10 V" operating mode, only working between 0 % and 100 % instead of between 0 V and 10 V.

⇒ see formula [1]

Parallel operation and a sequential circuit with identical or differing pressures can also be implemented via MP-Bus control.

⇒ see examples 1 ... 3 ▶ page 10

$$P_{ref} [Pa] = P_{min} [Pa] + (P_{max} [Pa] - P_{min} [Pa]) \cdot MP (\%) : 100 \% \quad [1]$$

In bus operation, terminal 15 can be used for additional functions:

- For the connection of analogue sensors or switches. In the process, the controller serves as an A/D converter, providing the master with digitised sensor or switching signals.

The controller can also be controlled using BACnet MS/TP and Modbus RTU.

6 Specification text

Maintenance-free, electronic pressure controller for constant and variable pressures. Rectangular design for position-independent installation in ventilation ducts for supply air and exhaust air in ventilation and air conditioning systems. Duct casing and blades made of galvanised sheet steel. Blades for pressure regulation centrally supported, bearing shafts made of stainless steel in special plastic bearing bushings. With seals on the blades for shutting off the ventilation duct. With integrated aluminium measurement cross for connecting an optional volumetric flow rate measuring device. High pressure accuracy across the entire pressure range. The pressure must be kept constant at variable pressures within the sensor-specific pressure measurement and control range. Maintenance-free standard actuator / spring return actuator / high-speed actuator 24 V AC/DC with LED status indicators, controller with integrated static / dynamic sensor for analogue and digital communication via MP-Bus, BACnet and Modbus. Operating modes constant or variable, with 0 to 10 V, 2 to 10 V or adjustable. Can be used for superimposed overrides for opening and closing the blades and for parallel and sequential operation of multiple pressure controllers. With actual pressure output signal, with acoustic insulation and sheet metal jacket. Leak tightness class ATC 3 (formerly C) for the casing, leak tightness class 4 for the blades, each in accordance with DIN EN 1751. Certificate of conformity as proof of compliance with the hygiene requirements in accordance with VDI 6022-1, VDI 3803-1, DIN 1946-4, DIN EN 16798-3, SWKI VA104-01, SWKI VA105-01, ÖNORM H6020 and ÖNORM H6021.

.....	pcs.		
	Reference pressure:	Pa to Pa
	Volumetric flow rate:	m³/h to m³/h
	Maximum pressure drop:	Pa
	Maximum sound power level		
	Flow noise	dB (A)
	Including SKE-V sound attenuator		
	Radiated noise	dB (A)
	Manufacturer:	WILDEBOER	
	Type:	DKpro	
	Width:	
	Height:	
	Complete with fastenings	supply:
		install:
.....	pcs. Volumetric flow rate measuring device, dynamic for registering the volumetric flow rate.	supply:
		install:
.....	pcs. Volumetric flow rate measuring device, static for registering the volumetric flow rate.	supply:
		install:
.....	pcs. Pressure tapping set for registering the static pressure in the ventilation duct.	supply:
		install:
.....	pcs. Sound attenuator SKE-V - L	supply:
		install:
.....	pcs. Link.10 setting device for setting and operation.	supply:
		install:

Select text not printed in bold as required!

This tender specification text can be found on the website www.ausschreiben.de ▶ ausschreiben.de.

Alternatively, you can use the tender specification text tailored to your product selection in the Wildeboer Connect web application ▶ [Wildeboer Connect](#).

7 Wildeboer makes it easy

7.1 Wildeboer Connect

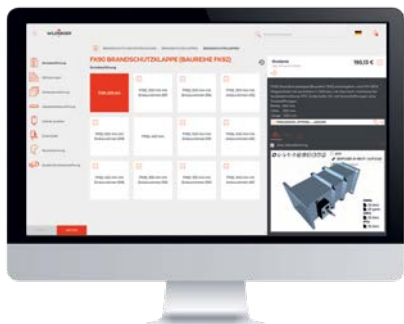

- High-performance configurator with customer-specific net prices
- Quick, intuitive product configuration of Wildeboer products
- Access to prices and unique version keys for ordering products
- Easy calculation of operating point data for configured products
- Interface to Autodesk Revit and AutoCAD for transferring CAD geometries
- Download of CAD data, data sheets, specification texts and further product documents in common data formats
- Transparent real-time order tracking
 - Detailed order information
 - Access to order documents
 - Access to shipment tracking



7.2 WiDim dimensioning software



- Functional, modern and intuitive dimensioning of Wildeboer products
- Conveniently collect operating point data, 3D product views, suitable accessories and current revision documents in a single project
- Project can be output in various formats
- A GAEB interface and an interface based on VDI 3805 facilitate a continuous planning process



7.3 Documents online



- Paperless and environmentally friendly online access to Wildeboer documents
- All documents in one central location and always up to date
- Supporting interactive formats and content



Always there for you

Locations & contact

WILDEBOER

Factory - Administration
+49 4951 950-0
info@wildeboer.de
www.wildeboer.de

Weener

Hamburg

Utrecht

Hanover

Berlin

Cologne

Frankfurt

Leipzig

Stuttgart

Ulm

Munich

WILDEBOER

Utrecht office
+31 30 767 0150
info@utrecht.wildeboer.eu
www.wildeboer.de/nl

WILDEBOER

Leipzig office
+49 34444 310-0
info@leipzig.wildeboer.de
www.wildeboer.de

WILDEBOER

Ulm office
+49 7392 9692-0
info@ulm.wildeboer.de
www.wildeboer.de



Find out more at
www.wildeboer.de/downloads

